



DMS

DELUXE MACHINE STAND



IMPORTANT!

Assembly may require the assistance of another person.

Before you begin assembly:

READ THE DIRECTIONS all the way through one time. This will speed up the process and help you understand the sequence of steps.

COUNT THE PARTS AND HARDWARE before assembly. This ensures you have received all necessary parts before you begin.

TOOLS: You may need a Phillips head screwdriver, a medium slotted screwdriver or a plastic mallet. To protect your new furniture from damage during assembly, it is recommended to work on a carpeted surface.

In the event any parts are missing from this package, send your name, address, telephone number, and a description of the missing part(s) to: PARTS, Box 1420, Missoula, MT 59806 or call: 1-800-769-5693 or FAX 1-800-445-5281.

CAUTION: On assemblies requiring glue, make sure the unit is assembled correctly before gluing. Once this unit is assembled with glue, the manufacturer will not be responsible for damaged parts. Keep a damp cloth or sponge handy to wipe off excess glue.

To care for this furniture, simply wipe with a cloth dampened with glass cleaner containing ammonia-D.

PARTS DIAGRAM

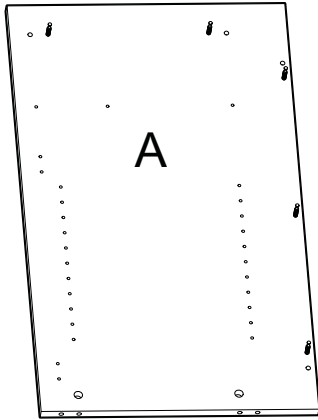

| | | |
|-----------|----------|-------|
| Left Side | 05850941 | 1 ea. |
|-----------|----------|-------|

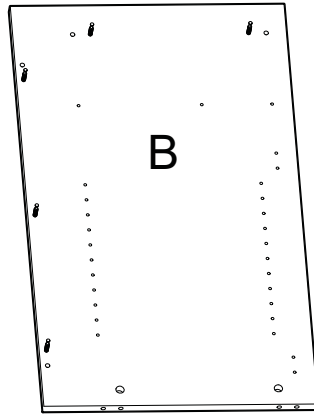

| | | |
|------------|----------|-------|
| Right Side | 05850941 | 1 ea. |
|------------|----------|-------|

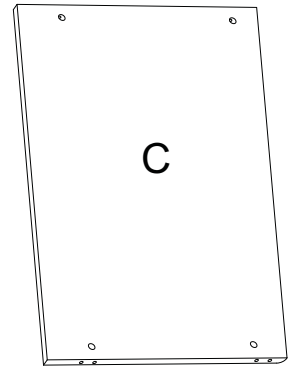

| | | |
|-----|---------|-------|
| Top | 0585091 | 1 ea. |
|-----|---------|-------|

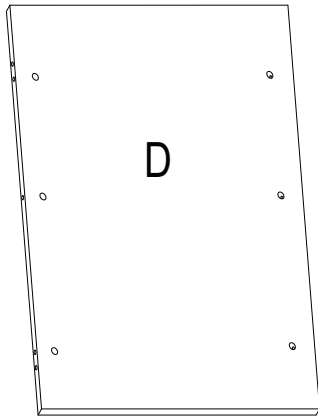

| | | |
|------|----------|-------|
| Back | 05850952 | 1 ea. |
|------|----------|-------|

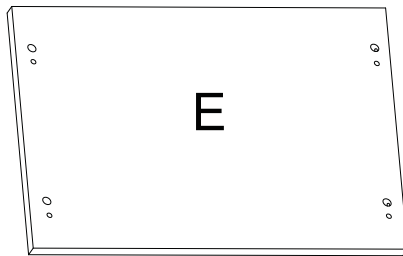

| | | |
|--------|---------|-------|
| Bottom | 0585091 | 1 ea. |
|--------|---------|-------|

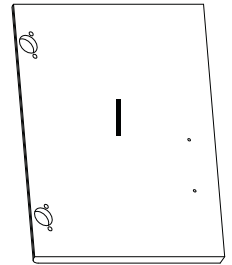

| | | |
|-----------|----------|-------|
| Left Door | 05850974 | 1 ea. |
|-----------|----------|-------|



| | | |
|-------------|--------|-------|
| Drawer Side | 068270 | 2 ea. |
|-------------|--------|-------|

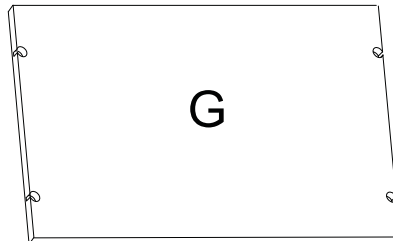

| | | |
|-------|----------|-------|
| Shelf | 05850924 | 1 ea. |
|-------|----------|-------|

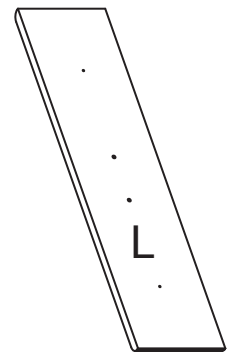

| | | |
|--------------|----------|-------|
| Drawer Front | 05850963 | 1 ea. |
|--------------|----------|-------|

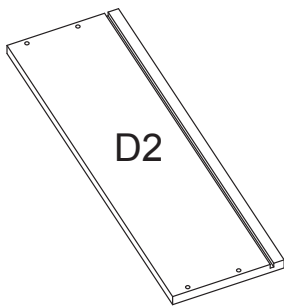

| | | |
|------------|--------|-------|
| Drawer End | 068070 | 2 ea. |
|------------|--------|-------|

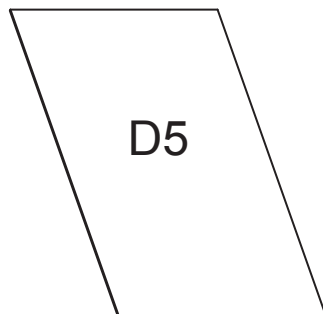

| | | |
|---------------|--------|-------|
| Drawer Bottom | 191665 | 1 ea. |
|---------------|--------|-------|

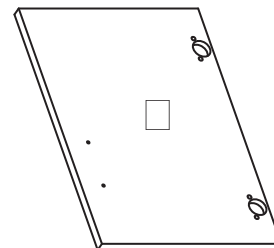

| | | |
|------------|----------|-------|
| Right Door | 05850974 | 1 ea. |
|------------|----------|-------|



| | | | |
|----|--------------------|--------|--------|
| H1 | Large Panead Screw | 988056 | 16 ea. |
|----|--------------------|--------|--------|



| | | | |
|----|--------------|--------|--------|
| H4 | Minifix Bolt | 909834 | 14 ea. |
|----|--------------|--------|--------|

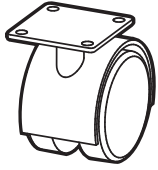

| | | | |
|----|--------------|---------|-------|
| H2 | Plate Caster | 4020501 | 2 ea. |
|----|--------------|---------|-------|



| | | | |
|----|------------|--------|--------|
| H5 | Wood Dowel | 195000 | 12 ea. |
|----|------------|--------|--------|

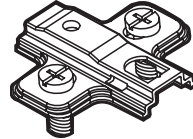

| | | | |
|----|-------------|--------|-------|
| H6 | Hinge Plate | 400201 | 4 ea. |
|----|-------------|--------|-------|

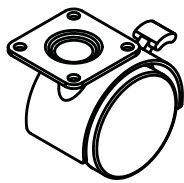

| | | | |
|----|----------------------|--------|-------|
| H3 | Plate Caster W/ Lock | 402051 | 2 ea. |
|----|----------------------|--------|-------|



| | | | |
|----|----------------|--------|-------|
| H7 | Varianta Screw | 988060 | 6 ea. |
|----|----------------|--------|-------|



| | | | |
|-----|-----------|--------|-------|
| H10 | Rafix Cam | 909910 | 4 ea. |
|-----|-----------|--------|-------|



| | | | |
|----|-------------|--------|--------|
| H8 | Minifix Cam | 909810 | 14 ea. |
|----|-------------|--------|--------|

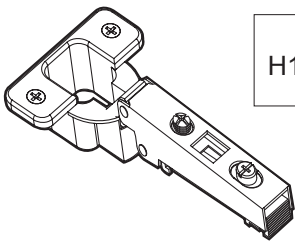

| | | | |
|-----|-------|--------|-------|
| H12 | Hinge | 400200 | 4 ea. |
|-----|-------|--------|-------|



| | | | |
|-----|------------|--------|-------|
| H11 | Rafix Bolt | 909923 | 4 ea. |
|-----|------------|--------|-------|



| | | | |
|-----|------------------|--------|-------|
| H13 | Bumper Stick-ons | 298032 | 2 ea. |
|-----|------------------|--------|-------|



| | | | |
|-----|------------------|--------|-------|
| H14 | Drawer/Door Pull | 400870 | 3 ea. |
|-----|------------------|--------|-------|



| | | | |
|-----|---------------------|--------|-------|
| H15 | 1" Washerhead Screw | 920200 | 6 ea. |
|-----|---------------------|--------|-------|

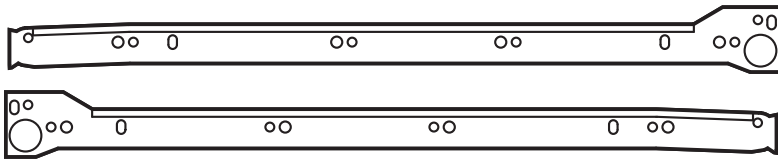

| | | | |
|----|-----------|--------|-------|
| S1 | 18" Slide | 490296 | 2 ea. |
|----|-----------|--------|-------|

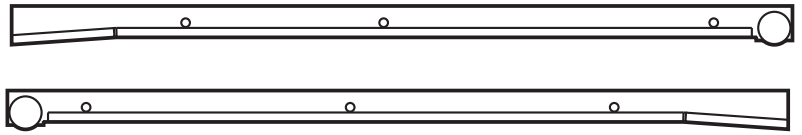

| | | | |
|----|-----------|--------|-------|
| S2 | 18" Slide | 490296 | 2 ea. |
|----|-----------|--------|-------|



| | | | |
|-----|------|--------|-------|
| H16 | Glue | 295020 | 1 ea. |
|-----|------|--------|-------|



| | | | |
|-----|-----------------|--------|-------|
| H17 | Confirmat Screw | 950100 | 8 ea. |
|-----|-----------------|--------|-------|



| | | | |
|-----|-------------------------|--------|-------|
| H20 | Phillips Flathead Screw | 901119 | 6 ea. |
|-----|-------------------------|--------|-------|

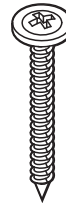

| | | | |
|-----|-------------------------|--------|-------|
| H19 | 1-1/2" Washerhead Screw | 920202 | 2 ea. |
|-----|-------------------------|--------|-------|

Using the Minifix System:

Insert the Minifix Cams into the appropriate holes with the arrow facing outwards as shown.

When screwing post into hole **Do Not** over tighten. Screw post down until bottom face of post flange just touches board surface.

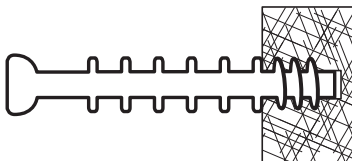

Using the #2 Phillips screwdriver rotate the Cam once a half turn clockwise until snug.

To disassemble turn the Cam once counter-clockwise and remove panels.

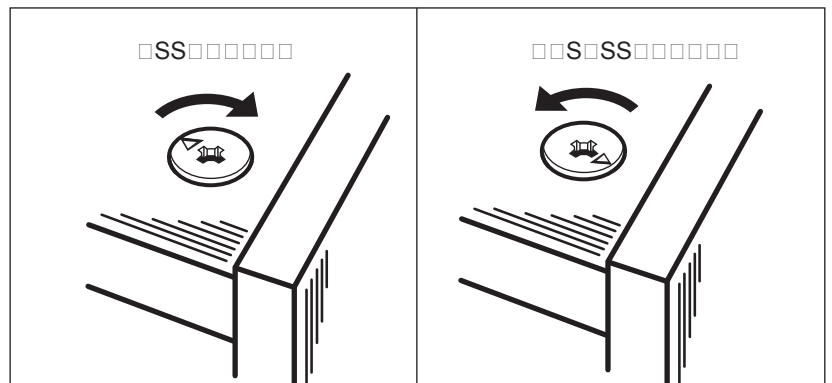
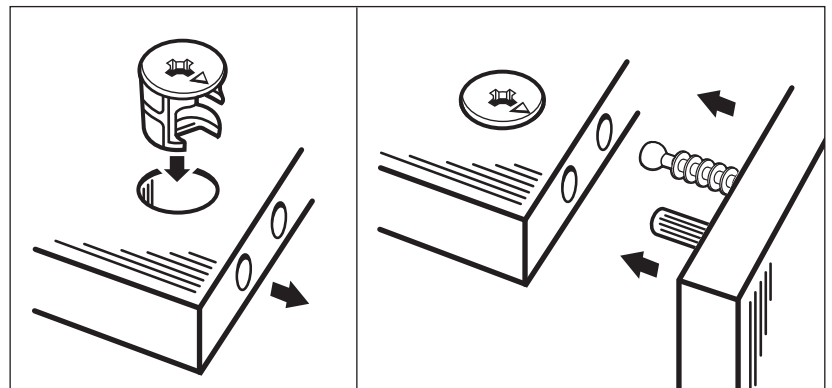

#1

Screw seven Minifix Bolts (H4) into the pre-drilled holes of Left Side (A) and seven Minifix Bolts into the pre-drilled holes of Right Side (B) where indicated.



H4

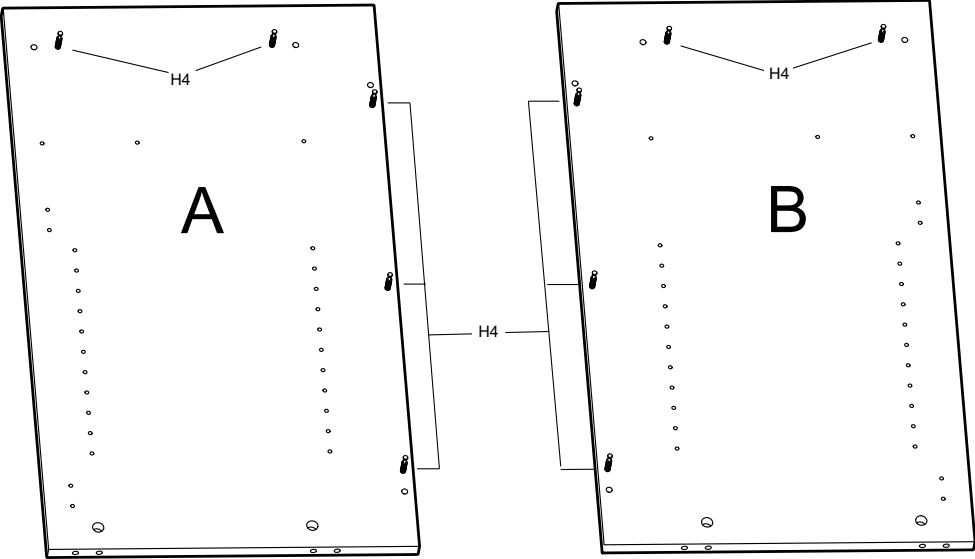

#2

Insert four Wood Dowels (H5) into the pre-drilled holes of the Left Side (A) and four Wood Dowels into the pre-drilled holes of the Right Side (B) where indicated.



H5

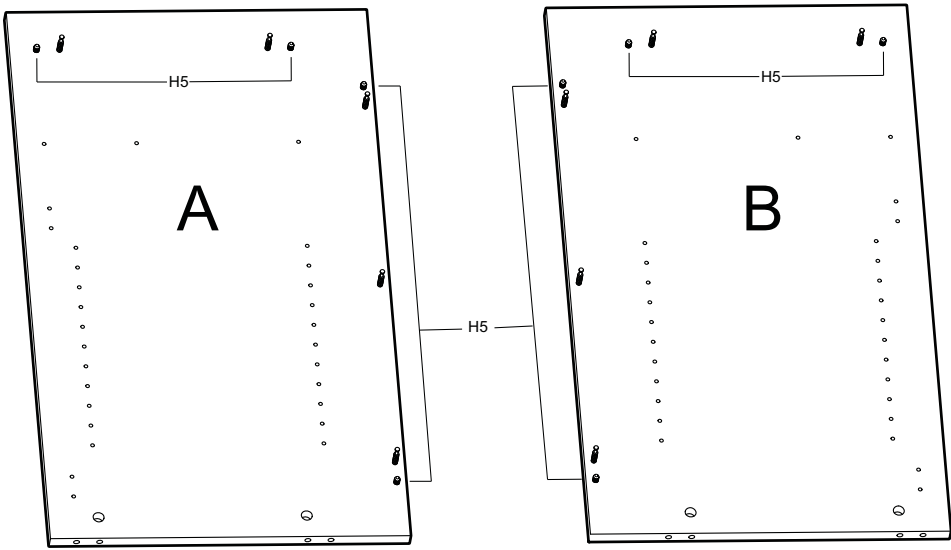

#3

Attach two Hinge Plates (H6) to the Left Side (A) and two Hinge Plates to the Right Side (B) using attached screws into the pre-drilled holes as shown.

IMPORTANT! The large hole and slots must be oriented to the rear edge of the Hinge Plates as shown.

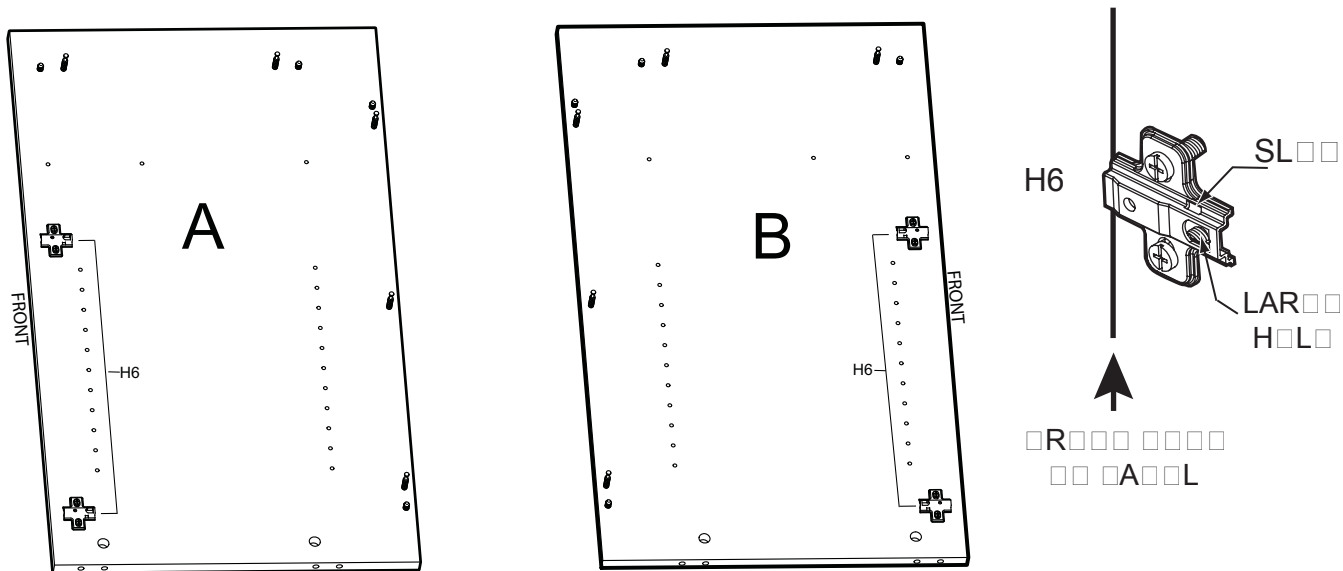

#4

Attach a right 18" Side Channel (S1) to the Right Side (B) using Varianta Screws (H7) in the upper set of pre-drilled holes as shown.

Attach a left 18" Side Channel (S1) to the Left Side (A) using Varianta Screws (H7) in the upper set of pre-drilled holes as shown.

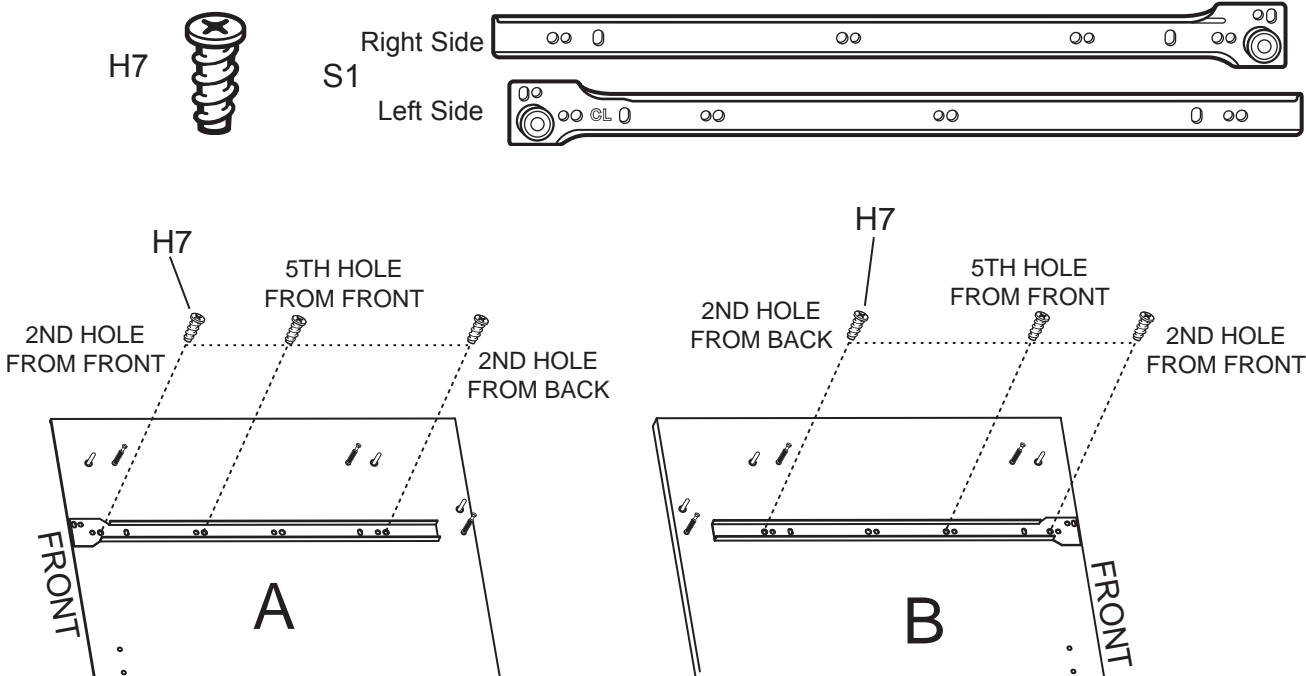

#5

Insert six Minifix Cams (H8) into the Back (D) facing out. Position Back onto Left Side (A) as shown and rotate Cams clockwise to secure.

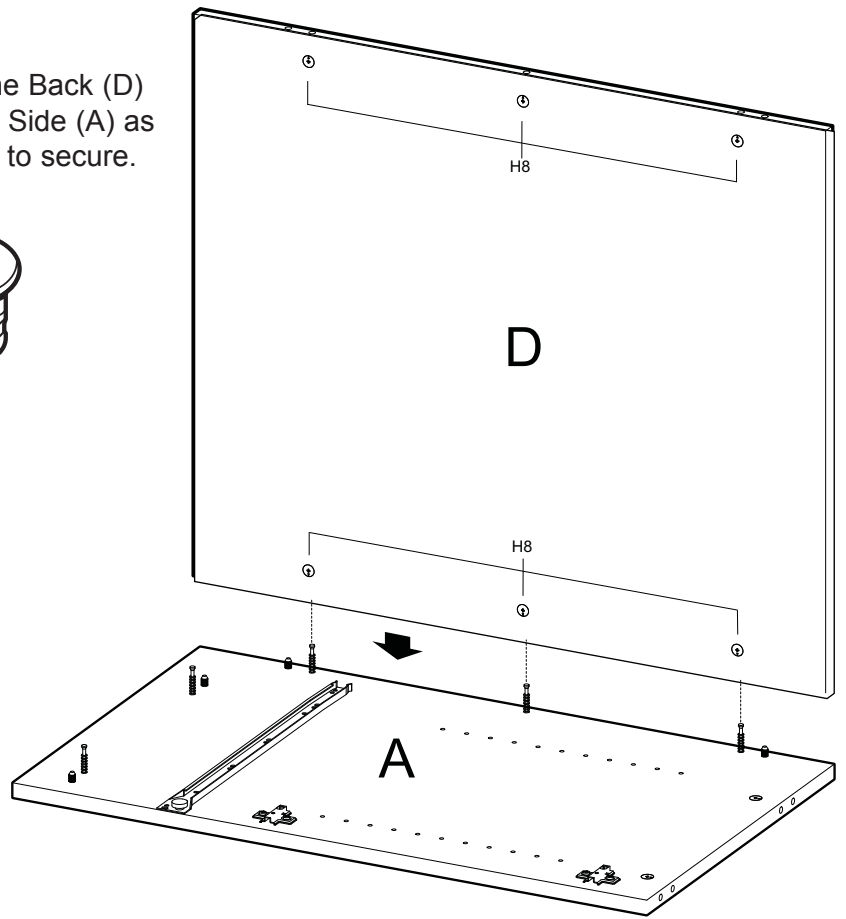

#6

Insert four Minifix Cams (H8) into the Top (C) facing out. Position Top onto Left Side (A) as shown and rotate Cams to secure.

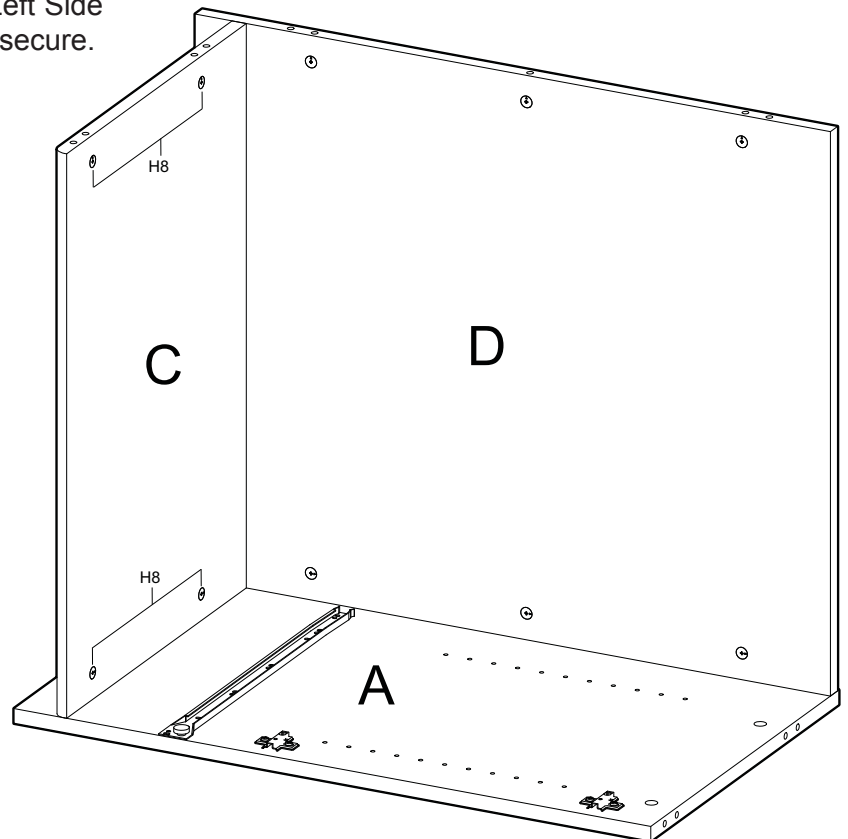

#7

Position the Right Side (B) Minifix Bolts and dowels into the corresponding Cams of the unit as shown.

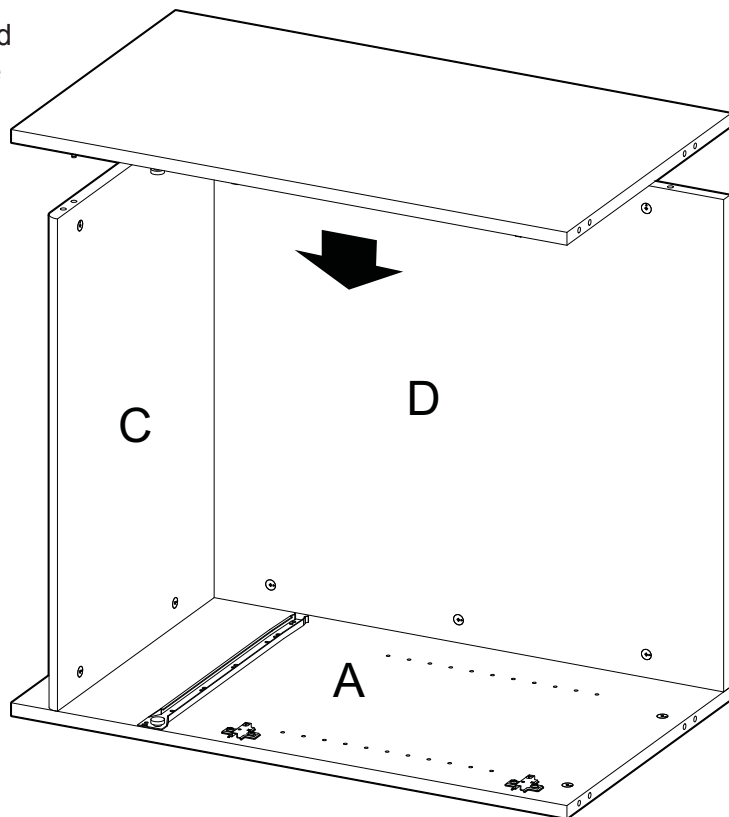

#8

Insert Bolts and Dowels into Bottom (E)
Position and secure.

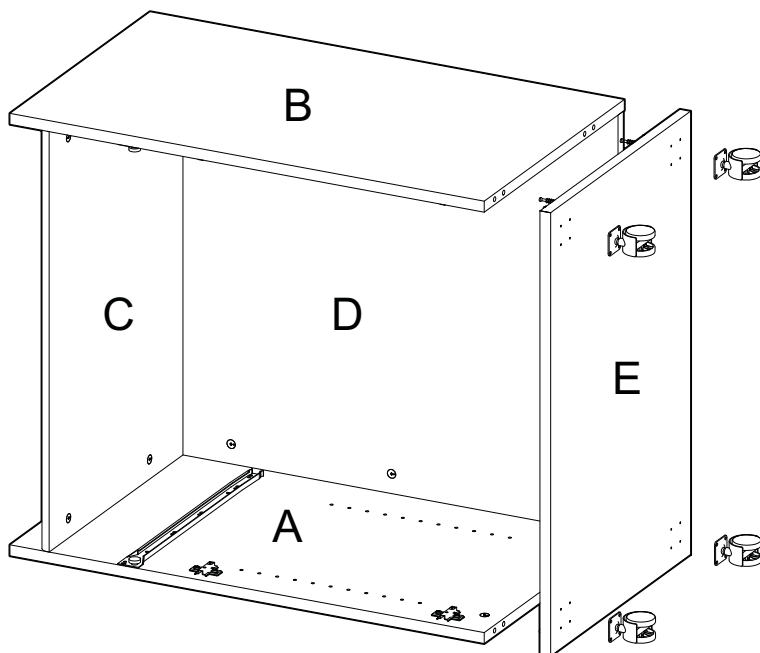

#9

Attach four Plate casters (H2 and H3) to the Bottom Panel (E) using the Panhead Screws in the pre-drilled holes as shown. (H1)

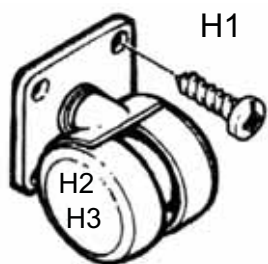



Insert the Rafx Cams into the appropriate holes. The flat edge of the cam should be facing the edge of the panel.

Slide Rafx Cams of the panel to be attached onto the corresponding posts.

When screwing post into hole do not over tighten. Screw post down until bottom face of post flange just touches board surface.

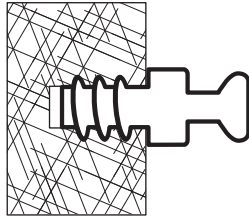

Using a Phillips screwdriver turn the rotating portion of the Rafx Cam a 1/2 turn clockwise to secure. **IMPORTANT!** Do not exceed 1/2 turn when tightening cams. Turn 1/2 turn counterclockwise to disassemble and remove panel.

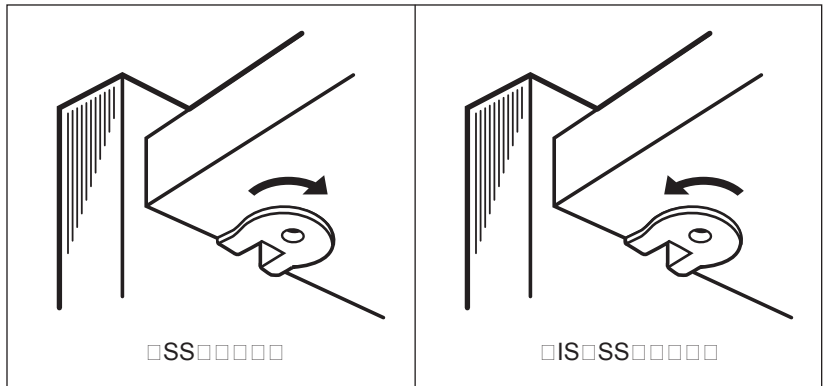
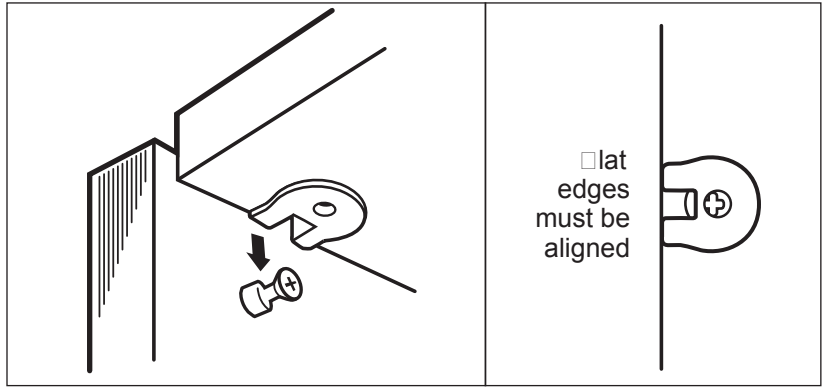

#11

Insert four Rafx Cams (H10) into the Shelf (G) facing outwards and tap until fully seated in place as shown.

IMPORTANT! The edge of the Rafx Cam must be aligned with the shelf edge. Rafx Cams are difficult to reposition if installed incorrectly.

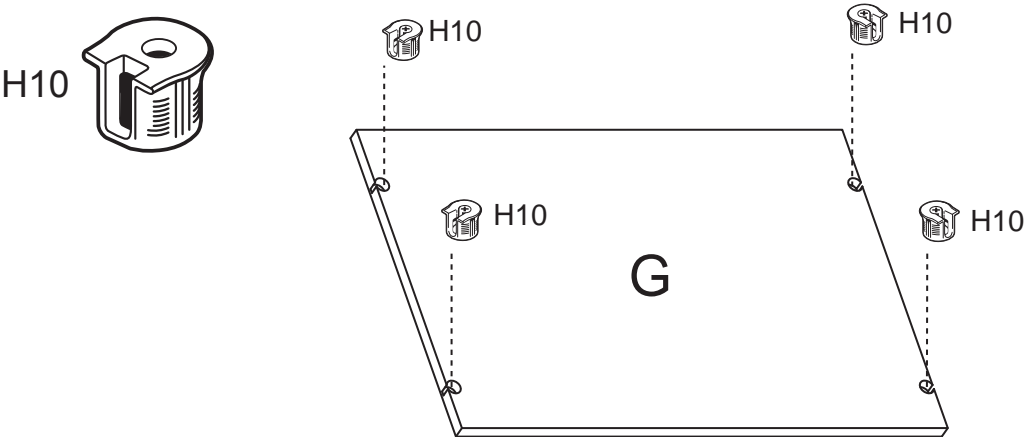

#12

Screw four Rafix Bolts (H11) into pre-drilled holes of each Side (A and B) at a selected height. Position the Shelf (G) onto the bolts as shown in the diagram preceding Step #11.

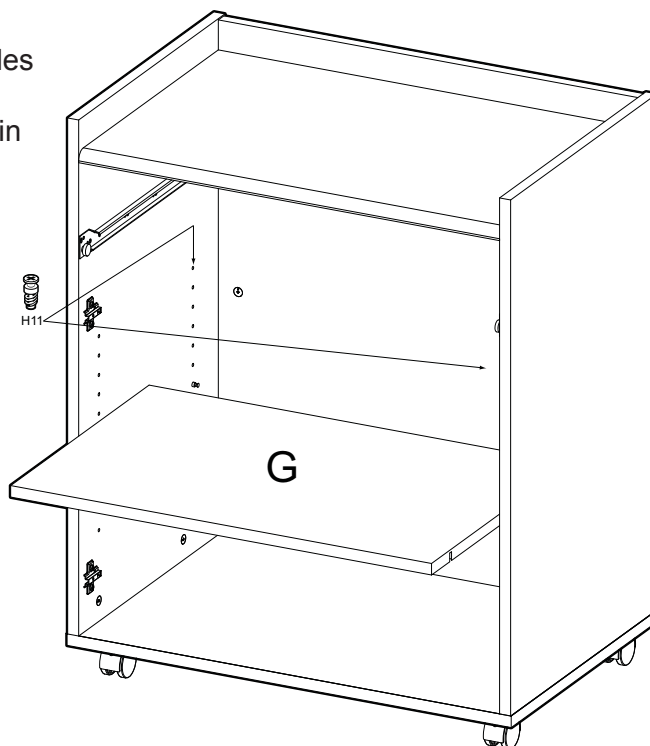

#13

Using a Plastic Mallet, insert the Hinges (H12) to the Left and Right Doors (I and J) as shown.

Remove backings and press Door Bumpers (H13) onto the opposite corners of Doors where indicated.

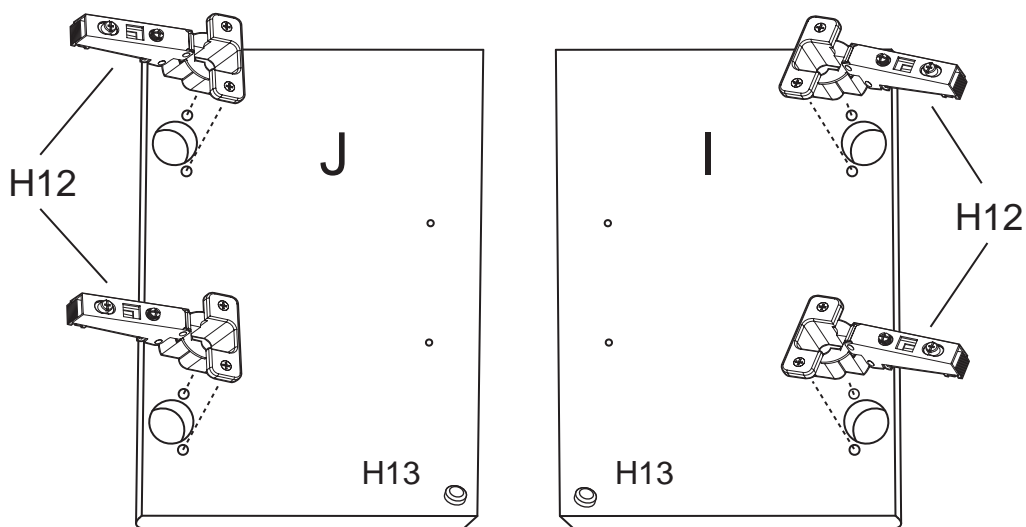

#14

Attach a Drawer Pull (H14) to each Door (I and J) using 1" Washerhead Screws (H15) as shown.

H14



H15

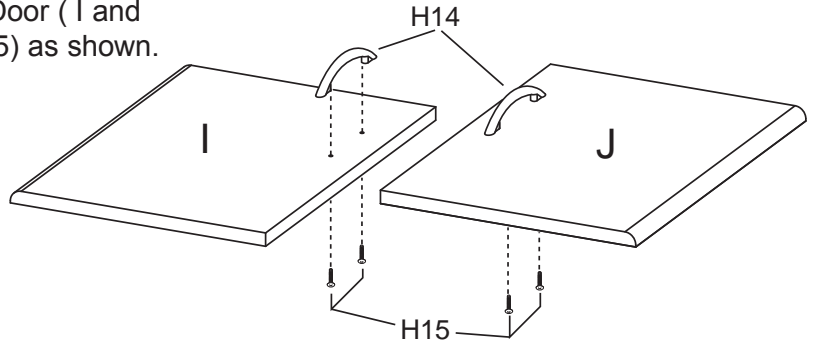
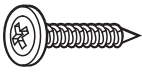

#15

To attach the Doors (I and J) to the unit, slide the slots of the Hinges (H12) onto the Hinge Plates (H6) until the release buttons click into place.

Adjust Doors (I and J) to open and close easily by loosening hinge screws and repositioning Hinge as shown. Tighten hinge screws when proper alignment is achieved.

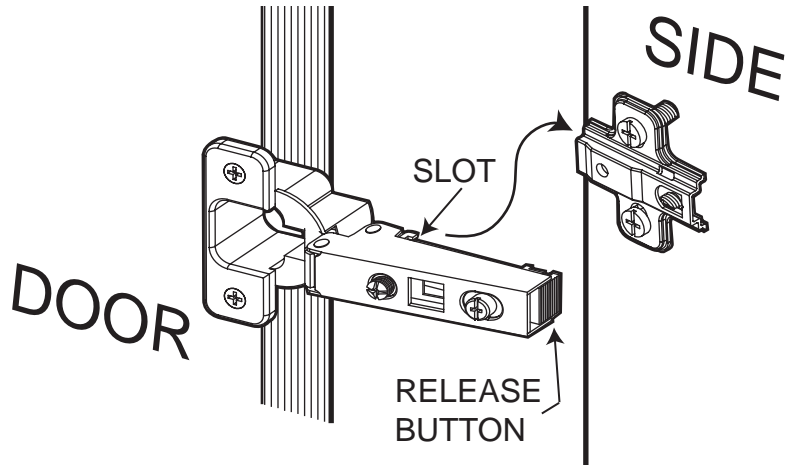
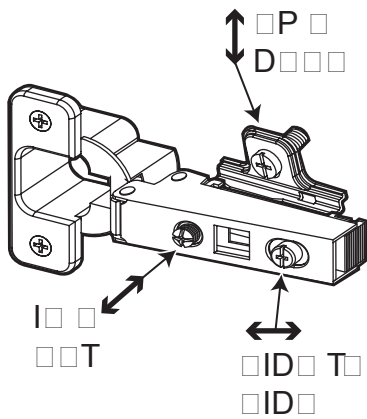

#16

Spread a thin layer of Glue (H16) on one edge of each Drawer End (D2) as shown.

Use four Phillips Head Screws (H17) to attach Drawer Ends (D2) to a Drawer Side (D1) with the grooves aligned on the inside as shown.

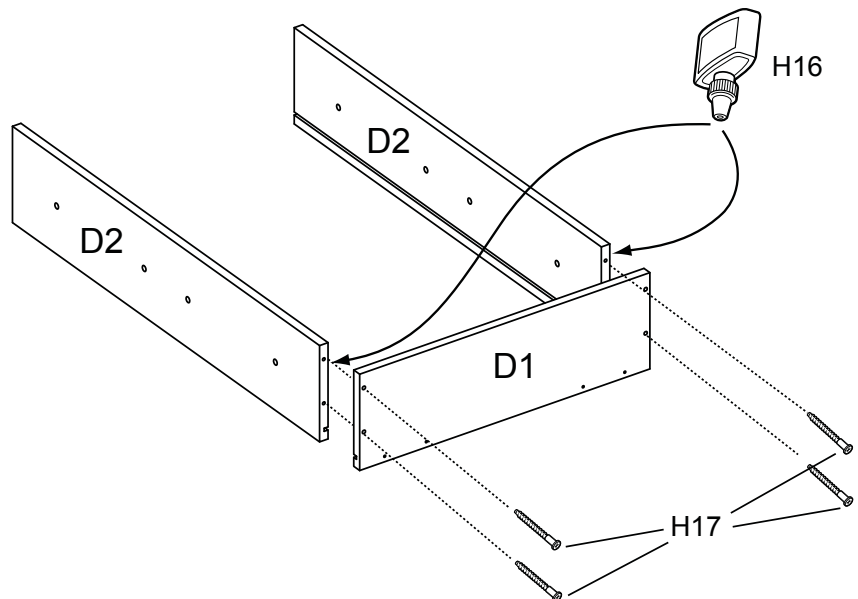

#17

Spread a thin layer of glue on both end edges and one side edge of Drawer Bottom (D5).

Slide the Drawer Bottom (D5) into grooves of the Drawer Ends (D2) until seated into the Drawer Side (D1) groove as shown.

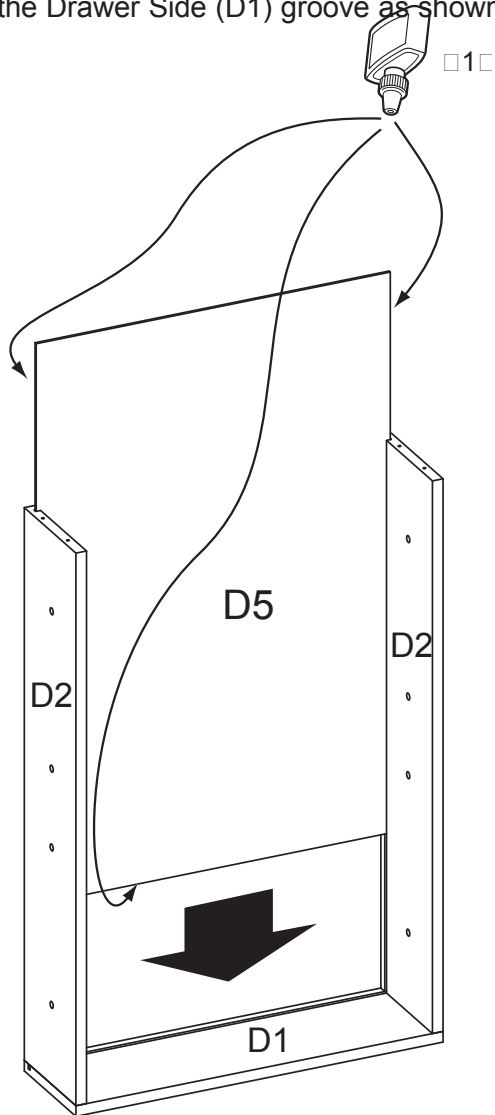

#18

Apply glue to the exposed edge of the Drawer Bottom (D5) and Drawer Ends (D2). Position the other Drawer Side (D1) onto unit with the groove aligned with the edge of the bottom.

Secure Drawer Side (D1) to the Drawer Ends (D2) using the Allen Head Screws (H17) as shown.

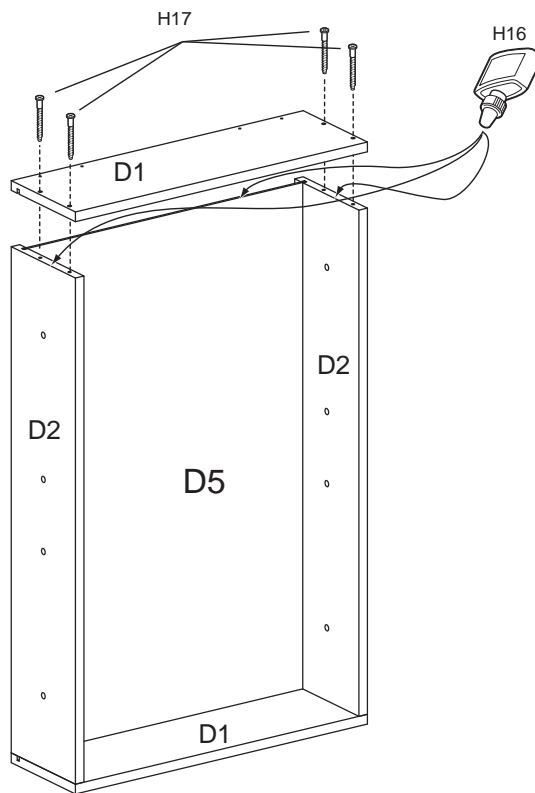

#19

Attach the Drawer Front (L) to the Drawer assembly using two Washerhead Screws (H18) as shown.

Attach a Drawer Pull (H15) to the Drawer Front (L) as shown using two 1-1/2" Washerhead Screws (H19).

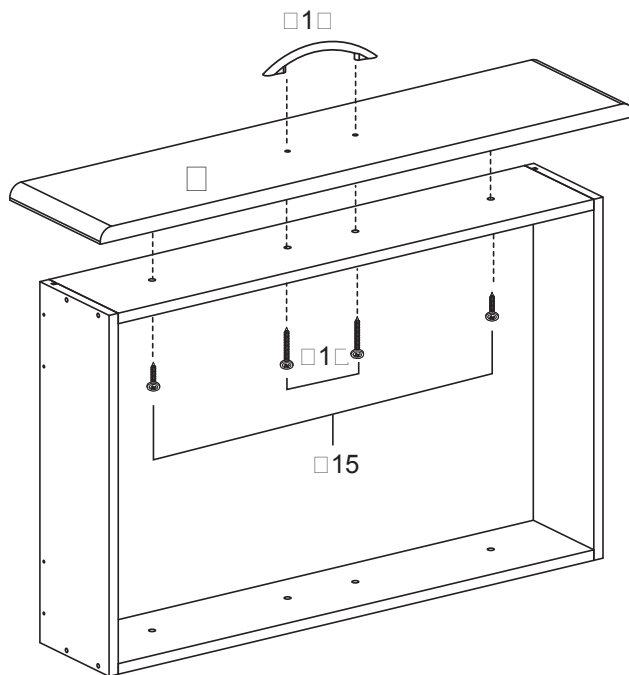
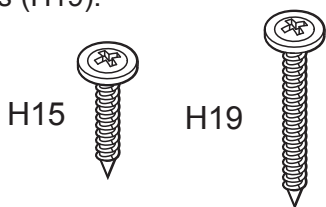

#20

Attach the left Shelf Slide (S2) to the Drawer unit using the Flathead Screws (H20) in the indicated holes as shown.

Attach the right Shelf Slide (S2) to the Drawer unit using the Flathead Screws (H20) in the indicated holes as shown.

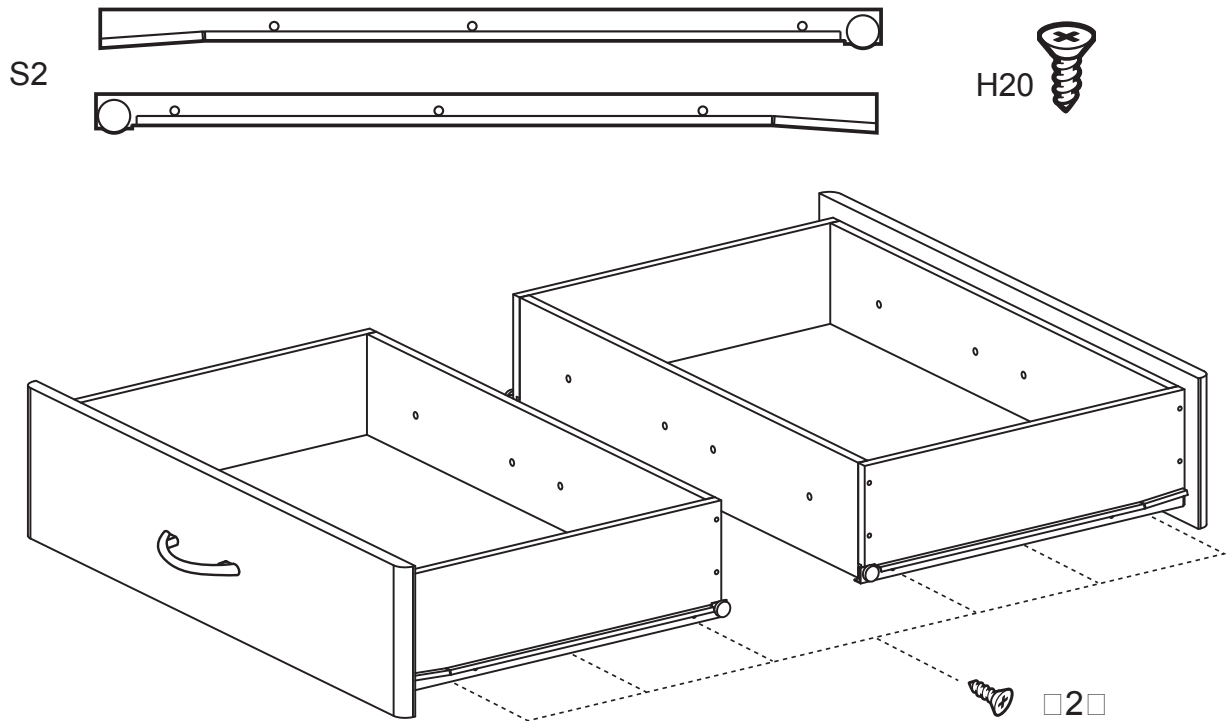

NOTE: Position the Slides with the flanges up and the rollers to the back as shown.

#21

Slide the drawer assembly onto the Side Channels (S2) of the unit as shown.

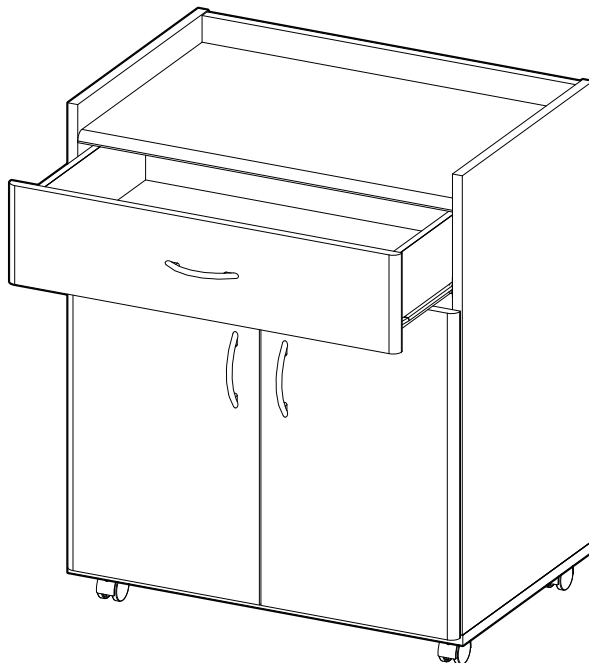

#22

With the drawer in place, check to insure that the Drawer Front (L) is aligned level and with equal spacing at the edges.

If the Drawer Front needs adjustment, loosen Washer Head Screws (H15) slightly, move Drawer Front to the correct [position and retighten screws.

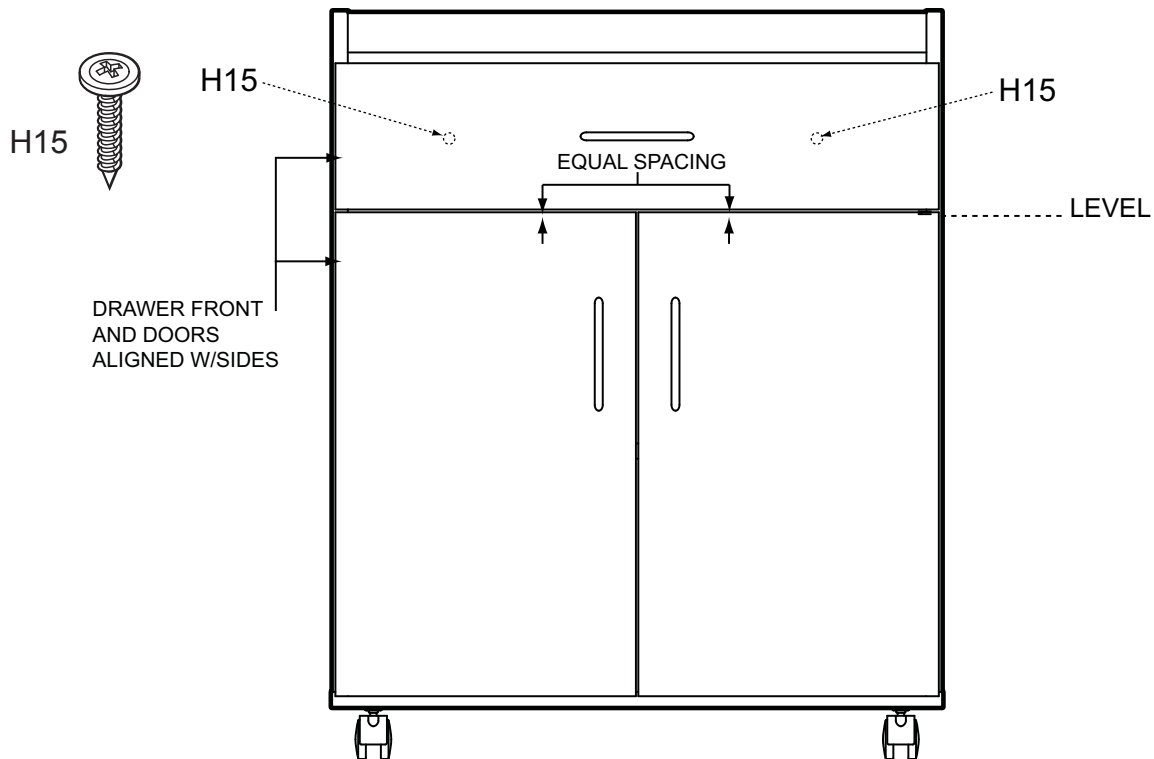

Your **Deluxe Machine Stand** is now assembled and ready to use.