

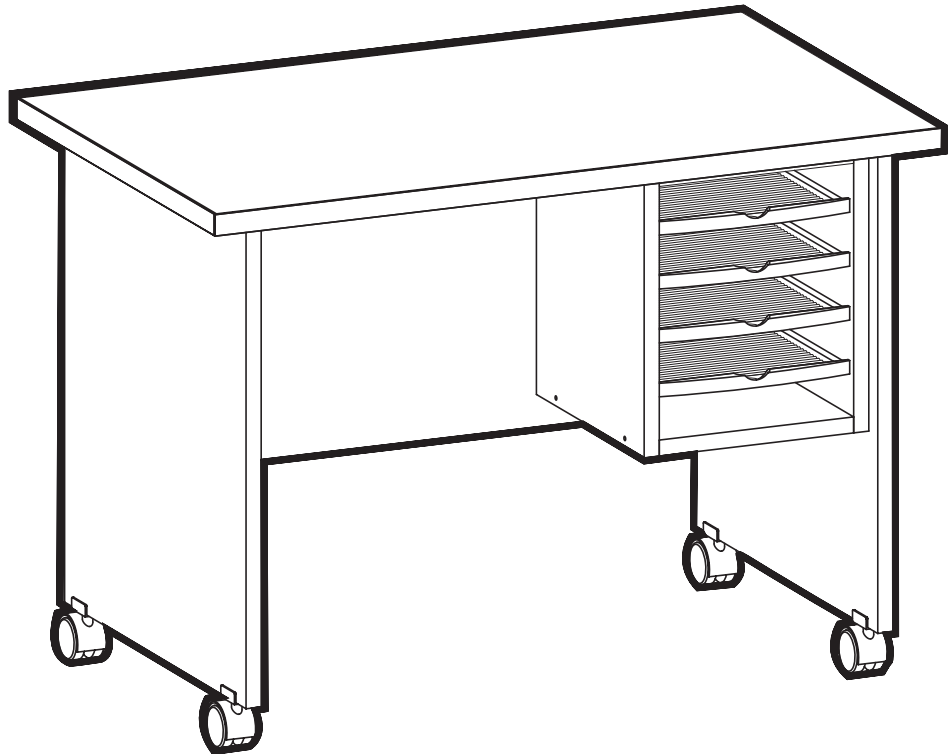

DTS

DELUXE TYPING STAND



IMPORTANT!

Assembly may require the assistance of another person.

Before you begin assembly:

READ THE DIRECTIONS all the way through one time. This will speed up the process and help you understand the sequence of steps.

COUNT THE PARTS AND HARDWARE before assembly. This ensures you have received all necessary parts before you begin.

TOOLS: You may need a Phillips head screwdriver, a medium slotted screwdriver or a plastic mallet. To protect your new furniture from damage during assembly, it is recommended to work on a carpeted surface.

In the event any parts are missing from this package, send your name, address, telephone number, and a description of the missing part(s) to: **PARTS, Box 1420, Missoula, MT 59806** or call: **1-800-769-5693** or **FAX 1-800-445-5281**.

CAUTION: On assemblies requiring glue, make sure the unit is assembled correctly before gluing. Once this unit is assembled with glue, the manufacturer will not be responsible for damaged parts. Keep a damp cloth or sponge handy to wipe off excess glue.

To care for this furniture, simply wipe with a cloth dampened with glass cleaner containing ammonia-D.

PARTS DIAGRAM

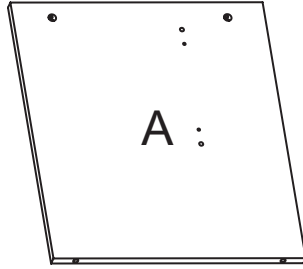

Left Side Panel	05850141	1 ea.
-----------------	----------	-------

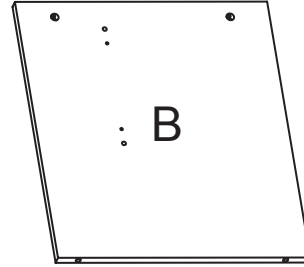

Right Side	05850341	1 ea.
------------	----------	-------

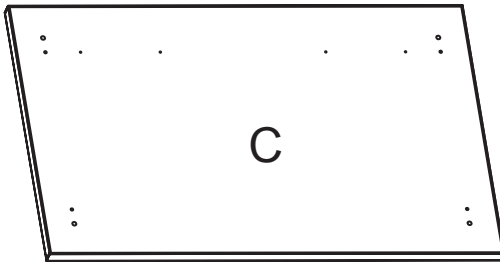

Worksurface	05850101	1 ea.
-------------	----------	-------

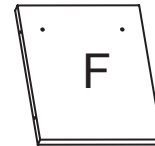

Paper Rack Top	05850118	1 ea.
----------------	----------	-------



Back	05850152	1 ea.
------	----------	-------

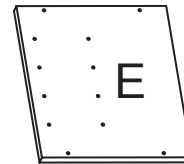

Paper Rack Side	05850116	2 ea.
-----------------	----------	-------

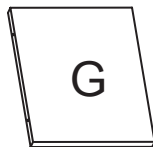

Paper Rack Bottom	05850119	1 ea.
-------------------	----------	-------

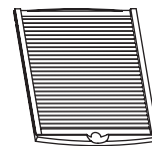

Paper Shelf w/Pins	H1053	4 ea.
--------------------	-------	-------

HARDWARE



H1	Minifix Bolt	909834	8 ea.
----	--------------	--------	-------



H2	Wood Dowel	195000	8 ea.
----	------------	--------	-------



H3	Minifix Cam	909810	8 ea.
----	-------------	--------	-------

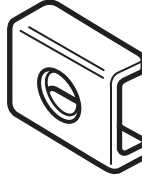

H4	Caster Bracket	402303	4 ea.
----	----------------	--------	-------



H5	Caster Socket	402301	4 ea.
----	---------------	--------	-------

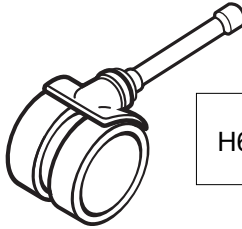

H6	Stem Caster	402290	4 ea.
----	-------------	--------	-------



H7	Confirmat Screw	950100	9 ea.
----	-----------------	--------	-------



H8	Washer Head Screw	920201	2 ea.
----	-------------------	--------	-------

Using the Minifix System:

Insert the Minifix Cams into the appropriate holes with the arrow facing outwards as shown.

When screwing post into hole, **Do Not** over tighten. Screw post down until bottom face of post flange just touches board surface.

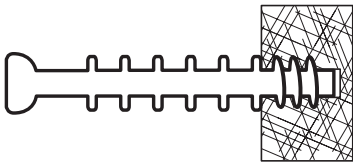

Using the #2 Phillips screwdriver, rotate the Cam Devices a half turn clockwise until snug.

To disassemble, turn the Cam Devices counter-clockwise and remove panels.

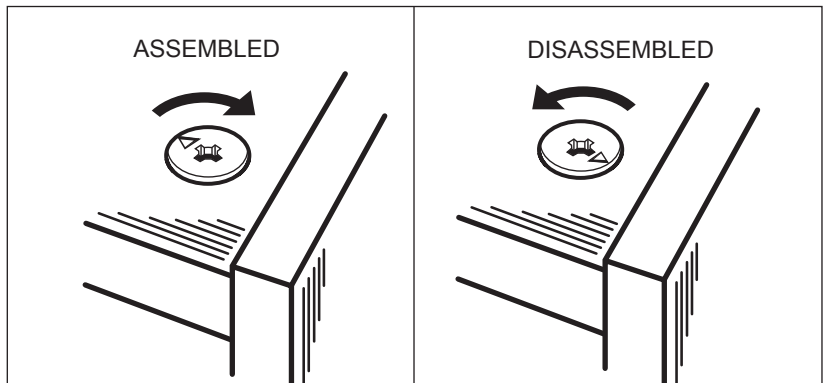
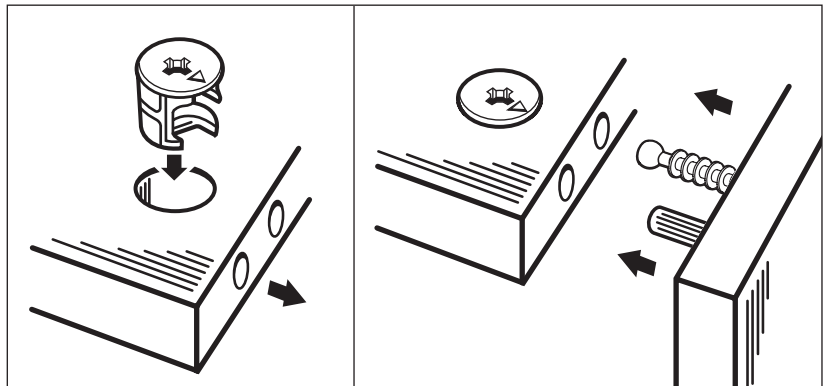

#1

Screw four Minifix Bolts (H1) into the pre-drilled holes of the Worksurface (C) where indicated.

Insert four Wood Dowels (H2) into Worksurface (C) where indicated.

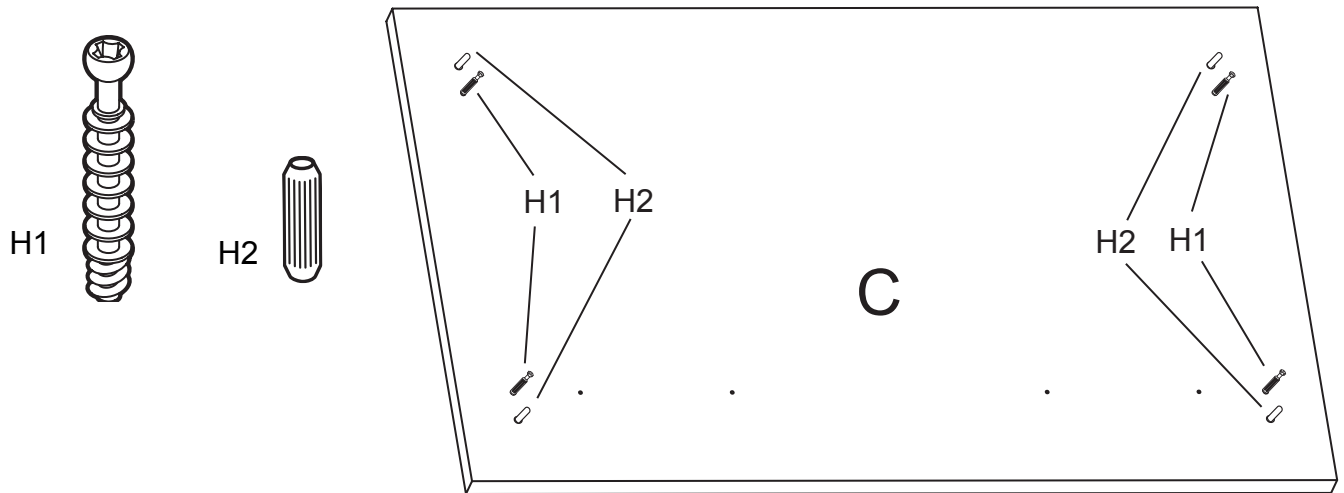

#2

- Screw two Minifix Bolts (H1) into pre-drilled holes of each Side (A and B) where indicated.
- Insert two Wood Dowels (H2) into pre-drilled holes of each Side (A and B) where indicated.
- Insert two Minifix Cams (H3) facing out into each Side (A and B) as shown.

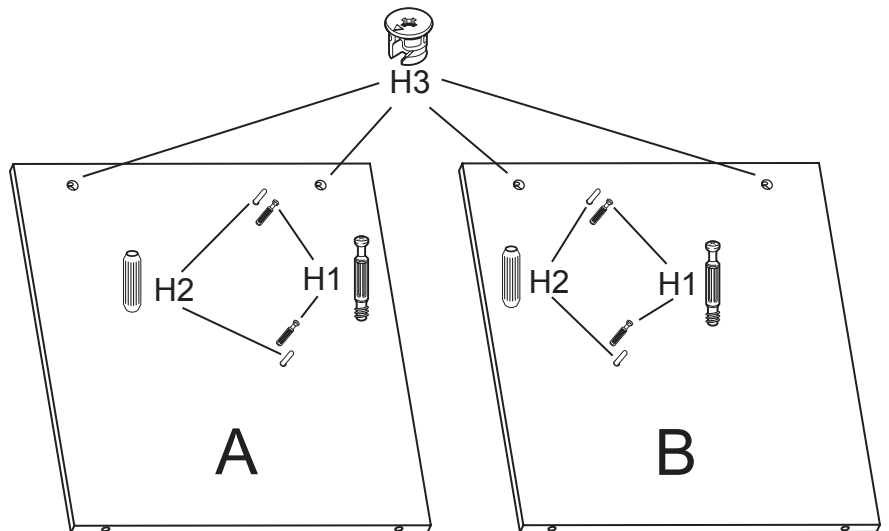

#3

Place Caster Brackets (H4) over the holes in the bottom edge of each Side. Insert Caster Sockets (H5) and tap until bottomed out against the Caster Brackets as shown.

Insert Casters (H6) into the Caster Sockets (H5) and tap into place as shown.

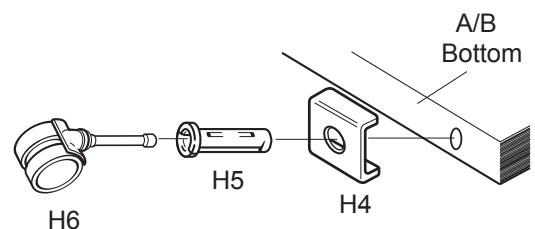

NOTE: The locking Casters should be installed toward the front of the unit.

#4

Insert four Minifix Cams (H3) into the Back (D) as shown. Position the Back onto the Left Side (A) as shown.

NOTE: Note the hole orientation on Back (D).

Rotate Minifix Cams clockwise to lock in place.

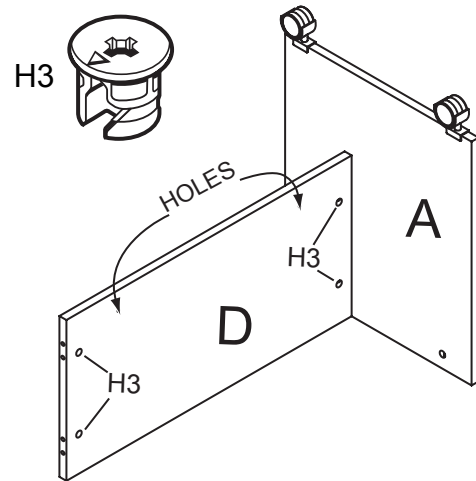

#5

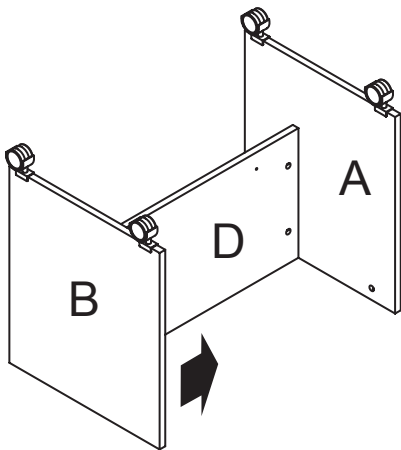

Position the Right Side (B) onto the Back (D) as shown.

Rotate Minifix Cams clockwise to lock in place.

#6

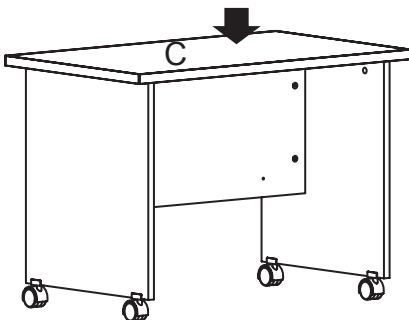

Turn the unit upright. Position the Cams and Dowels of the Worksurface (C) into the Minifix Cams of the unit as shown.

Rotate Minifix Cams (H3) clockwise to lock in place.

#7

Place a Paper Rack Side (E) with the unfinished edge down as shown. Use four Confirmat Screws (H7) to attach the Paper Rack Bottom (G) and Paper Rack Top (F) as shown.

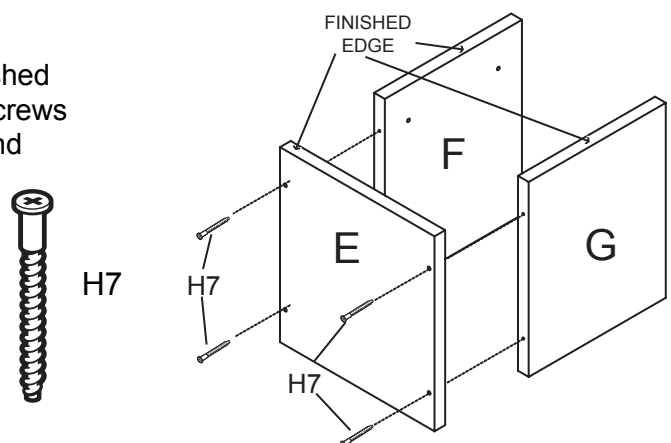

#8

Use four Confirmat Screws (H7) to attach the other Paper Rack Side (E) as shown.

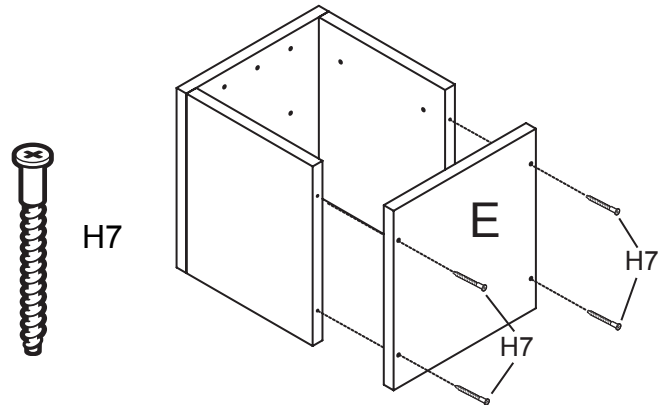

#9

Select either a left or right-hand Paper Rack placement. Attach Paper Rack unit to the underside of the Worksurface (C) using two Washerhead Screws (H8) in the pre-drilled holes as shown.

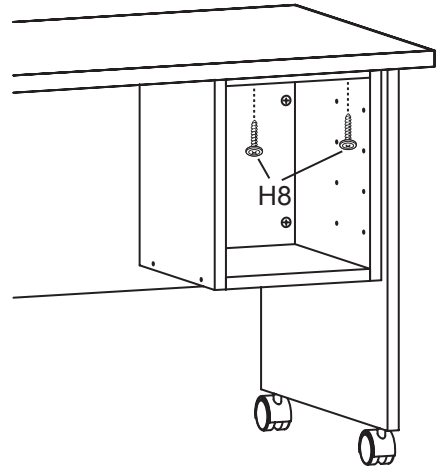

#10

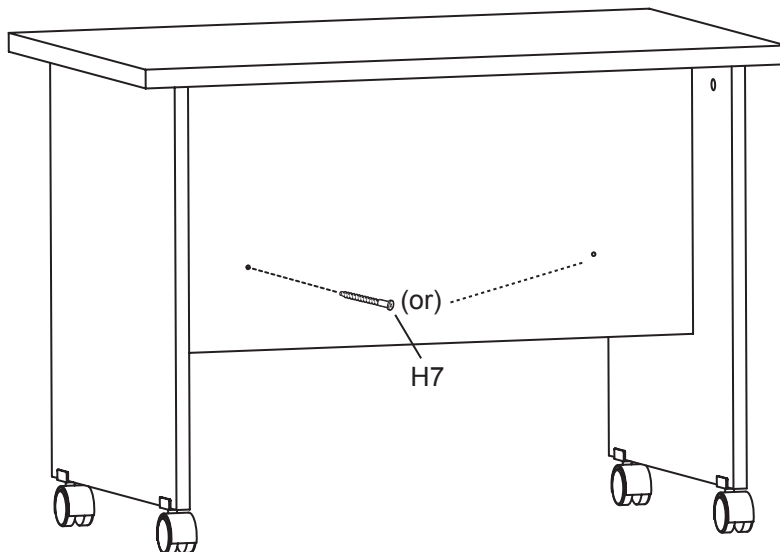

Use an Confirmat Screw (H7) through the Back (D) to secure Paper Rack to unit as shown.



#11

Turn each of the (4) plastic paper Trays upside-down and remove the four plastic pins located on the back edge of the tray.

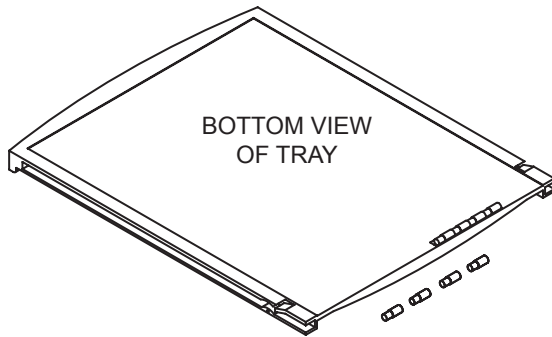

Insert eight Shelf Pins into the pre-drilled holes in both Paper Rack sides as shown.

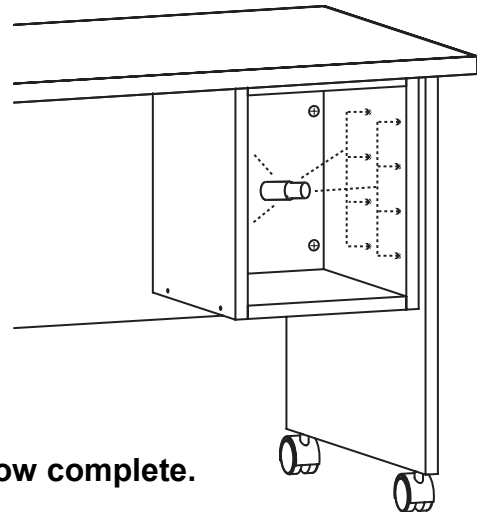

Assembly of the Deluxe Typing Stand is now complete.