



Operating Instructions and Parts Manual JBM-5 Benchtop Mortiser



JET
427 New Sanford Road
LaVergne, Tennessee 37086
Ph.: 800-274-6848
www.jettools.com

Part No. M-708580
Revision G3 01/2014
Copyright © 2014 JET

Warranty and Service

JET, Wilton and Powermatic warrants every product they sell against manufacturers' defects. If one of our tools needs service or repair, please contact Technical Service by calling 1-800-274-6846, 8AM to 5PM CST, Monday through Friday

Warranty Period

The general warranty lasts for the time period specified in the literature included with your product or on the official JET, Wilton or Powermatic branded websites.

- JET, Wilton and Powermatic products carry a limited warranty which varies in duration based upon the product. (See chart below)
- Accessories carry a limited warranty of one year from the date of receipt.
- Consumable items are defined as expendable parts or accessories expected to become inoperable within a reasonable amount of use and are covered by a 90 day limited warranty against manufacturer's defects.

Who is Covered

This warranty covers only the initial purchaser of the product from the date of delivery.

What is Covered

This warranty covers any defects in workmanship or materials subject to the limitations stated below. This warranty does not cover failures due directly or indirectly to misuse, abuse, negligence or accidents, normal wear-and-tear, improper repair, alterations or lack of maintenance.

Warranty Limitations

Woodworking products with a Five Year Warranty that are used for commercial or industrial purposes default to a Two Year Warranty. Please contact Technical Service at 1-800-274-6846 for further clarification.

How to Get Technical Support

Please contact Technical Service by calling 1-800-274-6846. **Please note that you will be asked to provide proof of initial purchase when calling.** If a product requires further inspection, the Technical Service representative will explain and assist with any additional action needed. JET, Wilton and Powermatic have Authorized Service Centers located throughout the United States. For the name of an Authorized Service Center in your area call 1-800-274-6846 or use the Service Center Locator on the JET, Wilton or Powermatic website.

More Information

JET, Wilton and Powermatic are consistently adding new products. For complete, up-to-date product information, check with your local distributor or visit the JET, Wilton or Powermatic website.

How State Law Applies

This warranty gives you specific legal rights, subject to applicable state law.

Limitations on This Warranty

JET, WILTON AND POWERMATIC LIMIT ALL IMPLIED WARRANTIES TO THE PERIOD OF THE LIMITED WARRANTY FOR EACH PRODUCT. EXCEPT AS STATED HEREIN, ANY IMPLIED WARRANTIES OF MERCHANTABILITY AND FITNESS FOR A PARTICULAR PURPOSE ARE EXCLUDED. SOME STATES DO NOT ALLOW LIMITATIONS ON HOW LONG AN IMPLIED WARRANTY LASTS, SO THE ABOVE LIMITATION MAY NOT APPLY TO YOU.

JET, WILTON AND POWERMATIC SHALL IN NO EVENT BE LIABLE FOR DEATH, INJURIES TO PERSONS OR PROPERTY, OR FOR INCIDENTAL, CONTINGENT, SPECIAL, OR CONSEQUENTIAL DAMAGES ARISING FROM THE USE OF OUR PRODUCTS. SOME STATES DO NOT ALLOW THE EXCLUSION OR LIMITATION OF INCIDENTAL OR CONSEQUENTIAL DAMAGES, SO THE ABOVE LIMITATION OR EXCLUSION MAY NOT APPLY TO YOU.

JET, Wilton and Powermatic sell through distributors only. The specifications listed in JET, Wilton and Powermatic printed materials and on official JET, Wilton and Powermatic-branded websites are given as general information and are not binding. JET, Wilton and Powermatic reserve the right to effect at any time, without prior notice, those alterations to parts, fittings, and accessory equipment which they may deem necessary for any reason whatsoever. JET® branded products are not sold in Canada by JPW Industries, Inc.

Product Listing with Warranty Period

90 Days – Parts; Consumable items; Light-Duty Air Tools
1 Year – Motors; Machine Accessories; Heavy-Duty Air Tools; Pro-Duty Air Tools
2 Year – Metalworking Machinery; Electric Hoists, Electric Hoist Accessories
5 Year – Woodworking Machinery
Limited Lifetime – Wilton branded products; JET Parallel clamps; VOLT Series Electric Hoists; Manual Hoists; Manual Hoist Accessories; Shop Tools; Warehouse & Dock products; Hand Tools

NOTE: JET, Wilton and Powermatic are divisions of JPW Industries, Inc.. References in this document to JET, Wilton and/or Powermatic also apply to JPW Industries, Inc., or any of its successors in interest to the JET, Wilton and/or Powermatic brands.

Table of Contents

Warranty and Service.....	2
Table of Contents.....	3
Introduction.....	3
Warning.....	4
Electrical Requirements.....	5
Specifications.....	6
Unpacking.....	6
Assembly.....	7
Installing.....	7
Adjustments.....	8
On-Off Switch.....	8
Handle Adjustment.....	8
Fence Adjustment.....	8
Hold Down Adjustment.....	8
Depth Stop Rod Adjustment.....	8
180° Head Rotation.....	8
Chuck Key Holder.....	8
Using Bits with Short Shanks.....	8
Chisel and Bit Adjustment.....	8
Adjusting Chisel Parallel to Workpiece.....	9
Storage.....	9
Optional Accessories.....	9
Replacement Parts.....	9
JBM-5 Benchtop Mortiser – Exploded View.....	10
JBM-5 Benchtop Mortiser – Parts List.....	11

Introduction

This manual is provided by JET covering the safe operation and maintenance procedures for a JET Model JBM-5 Mortiser. This manual contains instructions on installation, safety precautions, general operating procedures, maintenance instructions and parts breakdown. This machine has been designed and constructed to provide years of trouble free operation if used in accordance with instructions set forth in this manual. If there are any questions or comments, please contact either your local supplier or JET at: www.jettools.com.



Warnings

- **KEEP GUARDS IN PLACE** and in order.
- **REMOVE ADJUSTING KEYS AND WRENCHES.** Form the habit of checking to see that keys and adjusting wrenches are removed from the tool before turning it on.
- **KEEP THE WORK AREA CLEAN.** Cluttered areas and benches invite accidents.
- **DO NOT USE IN A DANGEROUS ENVIRONMENT.** Don't use power tools in damp or wet locations, or expose them to rain. Keep work area well lighted.
- **KEEP CHILDREN AWAY.** All visitors should be kept safe distance from the work area.
- **MAKE THE WORKSHOP KID PROOF** with padlocks, master switches, or by removing starter keys.
- **DON'T FORCE THE TOOL.** It will do the job better and safer at the rate for which it was designed.
- **USE THE RIGHT TOOL.** Don't force a tool or attachment to do a job for which it was not designed.
- **USE THE PROPER EXTENSION CORD.** Make sure your extension cord is in good condition. When using an extension cord, be sure to use one heavy enough to carry the current your product will draw. An undersized cord will cause a drop in the line voltage resulting in loss of power and overheating. **For runs up to 25 feet, use a 16 AWG or larger gauge cord. For runs up to 50 feet, use a 16 AWG or larger cord.** For runs up to 100 feet, use a 14 AWG or larger cord. If in doubt, use the next heavier gauge. The smaller the gauge number, the heavier the cord.
- **WEAR PROPER APPAREL.** Do not wear loose clothing, gloves, neckties, rings, bracelets, or other jewelry which may get caught in moving parts. Nonslip footwear is recommended. Wear protective hair covering to contain long hair.
- **ALWAYS USE SAFETY GLASSES.** Also use face or dust masks if the cutting operation is dusty. Everyday eyeglasses only have impact resistant lenses, they are NOT safety glasses.
- **SECURE WORK.** Use clamps or a vise to hold the work when it's practical. It's safer than using your hand and it frees both hands to operate the tool.
- **DON'T OVERREACH.** Keep proper footing and balance at all times.
- **MAINTAIN TOOLS WITH CARE.** Keep tools sharp and clean for best and safest performance. Follow instructions for lubricating and changing accessories.
- **DISCONNECT TOOLS** before servicing; when changing accessories, such as blades, bits cutters, and the like.
- **REDUCE THE RISK OF UNINTENTIONAL STARTING.** Make sure the switch is in the off position before plugging in the machine.
- **USE RECOMMENDED ACCESSORIES.** Consult the owner's manual for recommended accessories. The use of improper accessories may cause a risk of injury.
- **NEVER STAND ON A TOOL.** Serious injury could occur if the tool is tipped or if the cutting tool is unintentionally contacted.
- **CHECK DAMAGED PARTS.** Before further use of the tool, a guard or other part that is damaged should be carefully checked to determine that it will operate properly and perform its intended function. Check for alignment of moving parts, binding of moving parts, breakage of parts, mounting, and any other conditions that may affect its operation. A guard or other part that is damaged should be properly repaired or replaced.
- **DIRECTION OF FEED.** Feed work into a blade or cutter against the direction of rotation of the blade or cutter only.
- **NEVER LEAVE THE TOOL RUNNING UNATTENDED. TURN THE POWER OFF.** Don't leave the tool until it comes to a complete stop.
- **WARNING:** Some dust created by power sanding, sawing, grinding, drilling and other construction activities contains chemicals known to cause cancer, birth defects or other reproductive harm. Some examples of these chemicals are:
 - Lead from lead based paint.
 - Crystalline silica from bricks, cement and other masonry products.
 - Arsenic and chromium from chemically treated lumber.

Your risk of exposure varies, depending on how often you do this type of work. To reduce your exposure to these chemicals, work in a well-ventilated area and work with approved safety equipment, such as face or dust masks that are specifically designed to filter out microscopic particles.

Electrical Requirements

In the event of a malfunction or breakdown, grounding provides a path of least resistance for electric current to reduce the risk of electric shock. This tool is equipped with an electric cord having an equipment-grounding conductor and a grounding plug. The plug must be plugged into a matching outlet that is properly installed and grounded in accordance with all local codes and ordinances.

Do not modify the plug provided. If it will not fit the outlet, have the proper outlet installed by a qualified electrician.

Improper connection of the equipment-grounding conductor can result in a risk of electric shock. The conductor, with insulation having an outer surface that is green with or without yellow stripes, is the equipment-grounding conductor. If repair or replacement of the electric cord or plug is necessary, do not connect the equipment-grounding conductor to a live terminal.

Check with a qualified electrician or service personnel if the grounding instructions are not completely understood, or if in doubt as to whether the tool is properly grounded.

Use only three wire extension cords that have three-prong grounding plugs and three-pole receptacles that accept the tool's plug.*

Repair or replace a damaged or worn cord immediately.

This tool is intended for use on a circuit that has an outlet that looks like the one illustrated in Figure A below. The tool has a grounding plug that looks like the grounding plug as illustrated in Figure A below. A temporary adapter, which looks like the adapter as illustrated in Figure B below, may be used to connect this plug to a two-hole receptacle, as shown in Figure B if a properly grounded outlet is not available.** The temporary adapter should only be used until a properly grounded outlet can be installed by a qualified electrician. The green colored rigid ear or tab, extending from the adapter, must be connected to a permanent ground such as a properly grounded outlet box.

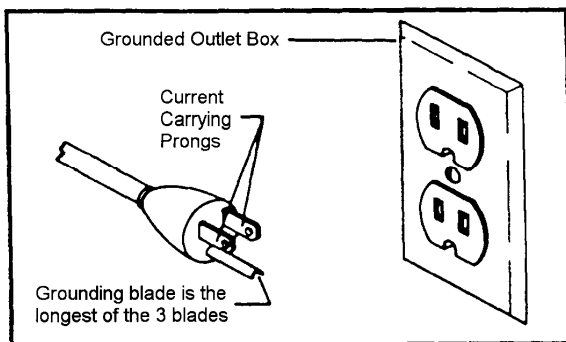

Fig. A

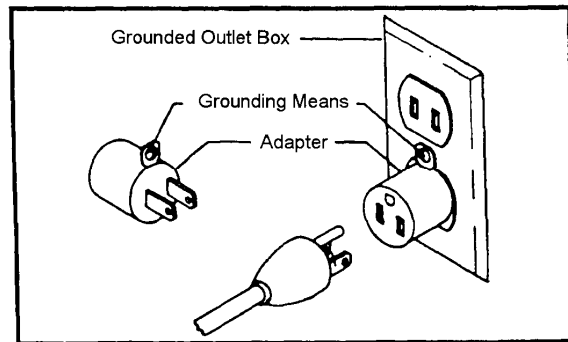

Fig. B

* Canadian electrical codes require extension cords to be certified SJT type or better.

** Use of an adapter in Canada is not acceptable.

Specifications

Stock Number	708580
Model Number	JBM-5
Motor	TEFC, 1/2HP, 1PH, 115V, 60Hz, 6A
RPM	1725
Switch.....	toggle, with removable safety key
Chuck Capacity (max. bit shank diameter)	3/8"
Chisel Capacity	1/2" x 1/2"
Chisel Shank Capacity	5/8", 3/4"
Head Stroke	4-3/4"
Chisel Center to Fence	3-1/2"
Under Hold-Down.....	4"
Fence Size	1-9/16" x 13-3/4"
Table Size	14" x 12-1/2"
Base Size	7-5/8" x 12-3/16"
Bushing Size	5/8" and 3/4"
Overall Height	maximum 30", minimum 21"
Net Weight	44 lbs.

The above specifications were current at the time this manual was published, but because of our policy of continuous improvement, JET reserves the right to change specifications at any time and without prior notice, without incurring obligations.

Unpacking

Open shipping container and check for shipping damage. Report any damage immediately to your distributor and shipping agent. Do not discard any shipping material until the Mortiser is assembled and running properly.

Compare the contents of your container with the following parts list to make sure all parts are intact. Missing parts, if any, should be reported to your distributor. Read the instruction manual thoroughly for assembly, maintenance and safety instructions.

Contents

- A. Mortising Machine
- B. Hydraulic Cylinder
- C. Handle
- D. 3/4" Chisel Bushing
- E. 5/8" Chisel Bushing
- F. Spindle Extension Adapter
- G. Chuck Key
- H. Table
- I. Hold Down
- J. Fence Assembly
- K. Screws (2)
- L. Owner's Manual (not shown)
- M. Warranty Card (not shown)

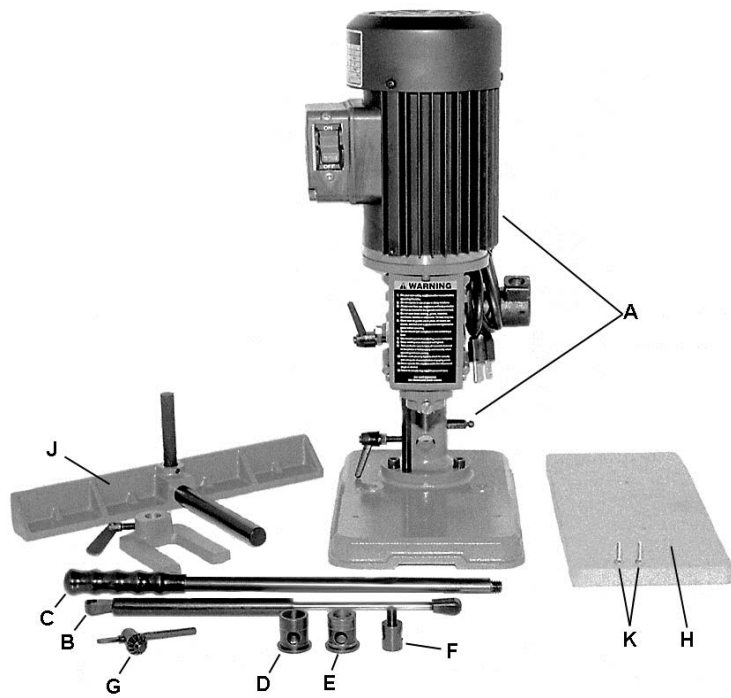

Figure 1

Assembly

⚠WARNING Never connect the machine to the power source until assembly is completed. Failure to comply may result in serious injury!

1. Screw the handle (A, Figure 2) into the pinion shaft (B, Figure 2).

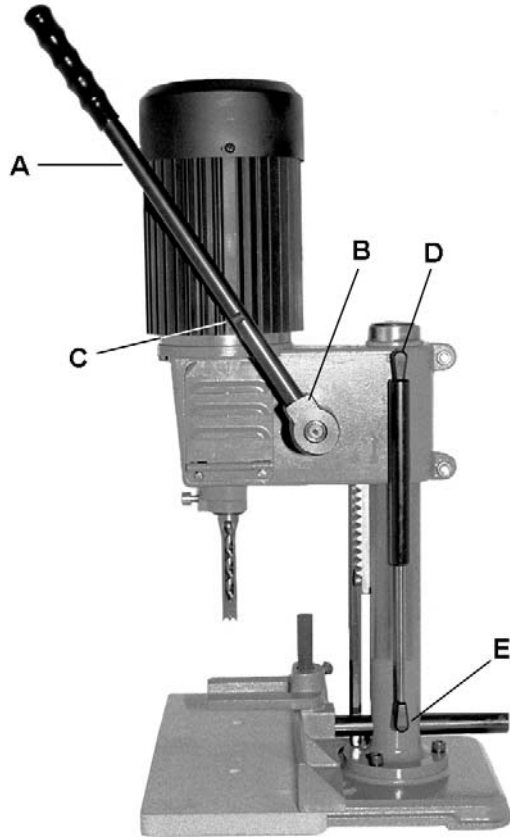

Figure 2
(chisel and bit not provided)

2. Tighten the handle. The handle has a notch (C, Figure 2) to accommodate a wrench.
3. Use the handle to raise the machine head to the up position. The handle is spring loaded and can be repositioned by pulling the handle away from the machine, and turned to the desired angle.
4. With the head in the up position press the hydraulic cylinder onto the two fittings. The upper fitting (D, Figure 2) is located on the head. The lower fitting (E, Figure 2) is on the column.
5. Attach the table to the base using two screws (A, Figure 3).
6. Insert bar of fence assembly (B, Figure 3) through the hole in the column. Use the fence-locking handle (C, Figure 3) to adjust fence assembly.

7. Attach the hold down (D, Figure 3) to the vertical post using locking handle (E, Figure 3).

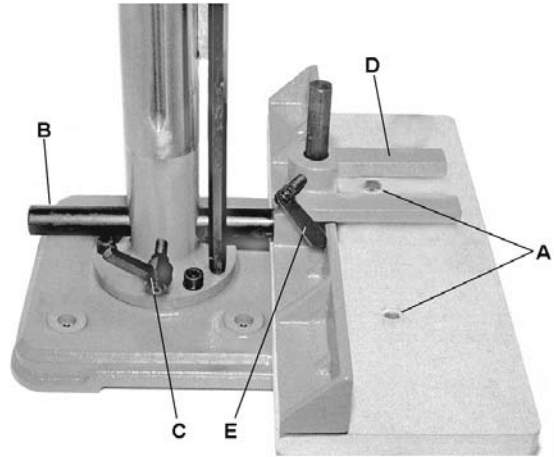

Figure 3

Installing

⚠WARNING Make sure the Mortising Machine is attached to a firm and stable support surface.

This machine must be fastened to a supporting surface to prevent it from tipping during operation. Four holes (A, Figure 4) in the base are supplied for this purpose.

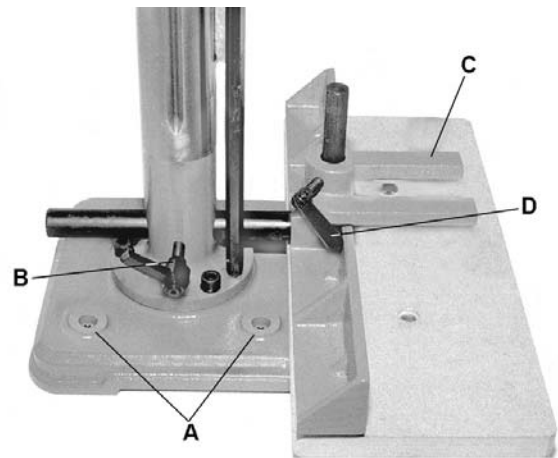

Figure 4

Adjustments

On-Off Switch

The switch (A, Figure 5) has a switch key that, when pulled out, allows the switch to be locked in the off position.

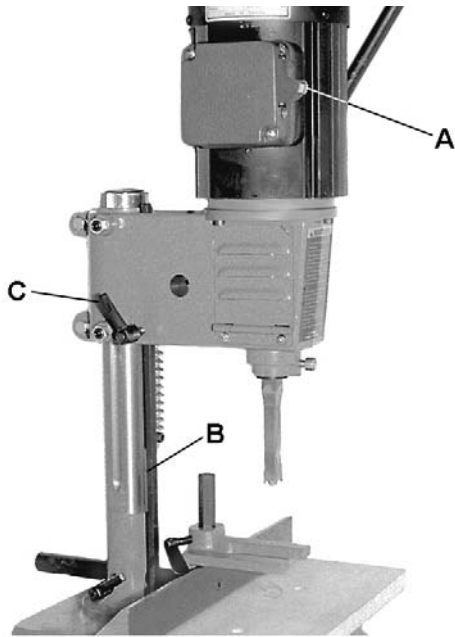

Figure 5

Handle Adjustment

The handle can be adjusted for leverage and comfort. Pulling the spring loaded handle (A, Figure 6) away from the head and turning allows you to change the position of the handle.

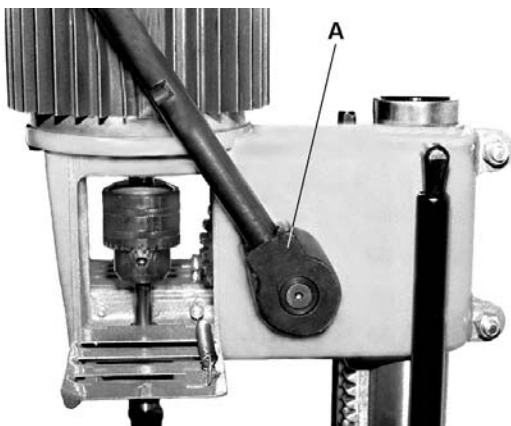

Figure 6

Fence Adjustment

The fence can be moved in and out by loosening the locking handle (B, Figure 4) on the column.

Hold Down Adjustment

The hold down (C, Figure 4) should be adjusted so it just touches the top of the workpiece and allows the workpiece to slide left or right. The hold down can also be taken off and turned over for a thicker workpiece. To adjust the hold down, loosen the locking handle (D, Figure 4).

Depth Stop Rod Adjustment

The depth stop rod (B, Figure 5) is provided to limit the depth of the chisel cut. Adjust the depth stop rod using the locking handle (C, Figure 5). Lower the head until the bottom of the chisel is at the required depth. Lower the depth stop rod until it is at rest against the base.

180° Head Rotation

Removing the three hex socket cap screws at the base will enable you to rotate the head and column 180°. Doing this will let the user mortise taller items.

Chuck Key Holder

The chuck key holder is located on the left side of the head.

Using Bits with Short Shanks

When using bits with short shanks, it will be necessary to attach the spindle extension adaptor. Place an open wrench on the flat part of the motor spindle. Use the chuck key to unscrew and remove the chuck. Attach the spindle extension to the chuck. Replace the chuck with the spindle extension into the motor spindle.

Chisel and Bit Adjustment

See Figure 7.

Note: Chisels and bits are available as optional accessories.

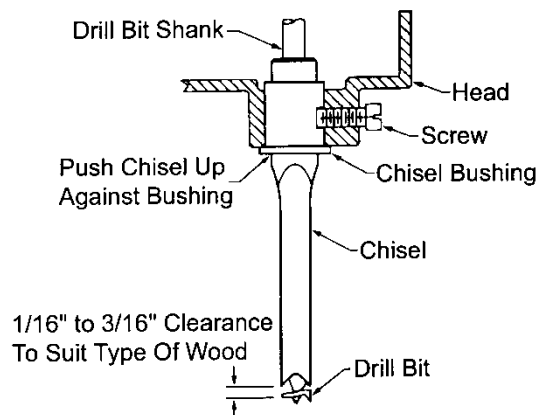

Figure 7

1. Insert chisel bushing with hole facing forward into the head. Tighten the screw just enough to hold the chisel in place.
2. Insert bit into the chisel. The opening in the chisel should always face to the right or left. The opening allows chips to escape during operation.
3. Push the chisel up as far as possible into the head. Then lower the chisel approximately 1/16" to 3/16". This may vary depending upon type of wood. Table 1 shows general guidelines for distance between points of chisel and bit point.
4. Tighten the screw to hold chisel in place.
5. Push bit up through the chisel opening as far as it will go. Lock the drill bit in place with chuck key.
6. Loosen screw and push chisel up against the bushing, and tighten the screw. This should provide the proper distance between the points of the chisel and the bit.

Type of wood	Chisel Size	Distance
Softwoods	1/4 to 3/8	1/32
	1/2	1/16 to 3/32
Hardwoods	1/4 to 3/8	1/16
	1/2	3/32 to 1/8

Table 1
(all dimensions inches)

Adjusting Chisel Parallel to Workpiece

The chisel can be adjusted parallel to the workpiece by loosening the screw (A, Figure 8) and rotating the chisel until the back surface of the chisel is flat against the workpiece. Tighten the screw to hold chisel in place.

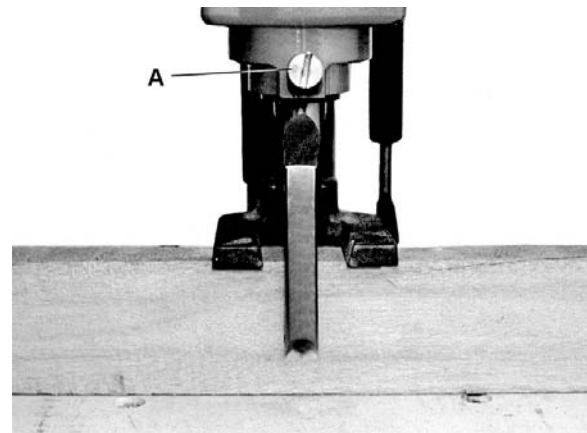

Figure 8

Storage

If the mortiser will be stored for an extended period, use the depth stop to help secure the head in position; this will relieve stress upon the hydraulic cylinder.

Optional Accessories

- 1791091 Premium 1/4" Mortise Bit and Chisel Set
- 1791092 Premium 5/16" Mortise Bit and Chisel Set
- 1791093 Premium 3/8" Mortise Bit and Chisel Set
- 1791094 Premium 1/2" Mortise Bit and Chisel Set

Replacement Parts

Replacement parts are listed on the following pages. To order parts or reach our service department, call 1-800-274-6848 Monday through Friday, 8:00 a.m. to 5:00 p.m. CST. Having the Model Number and Serial Number of your machine available when you call will allow us to serve you quickly and accurately.

JBM-5 Benchtop Mortiser – Exploded View

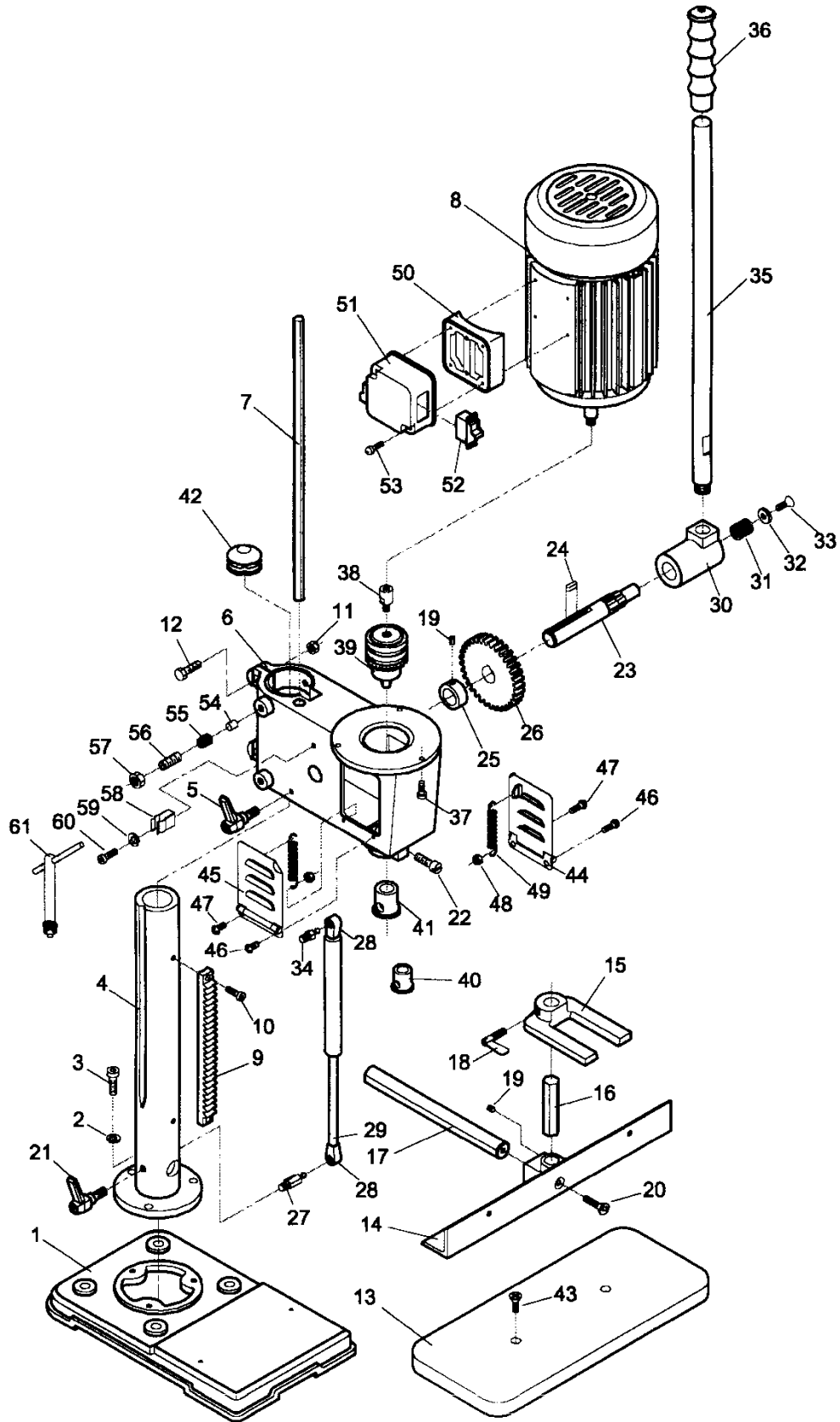

JBM-5 Benchtop Mortiser – Parts List

Index No.	Part No.	Description	Size	Qty
1	23011045W	Base		1
2	50302003	Lock Washer	5/16"	3
3	50102018	Hex Socket Cap Screw	M8x1.25x20	3
4	23011002W	Column		1
5	23011053	Lock Handle	M8x1.25x10	1
6	23011046W	Head		1
7	23011004	Depth Stop		1
8	23011054	Motor	1/2HP 1PH 115V	1
	23011054-01	Fan (not shown)		1
	23011054-02	Fan Cover (not shown)		1
	50154019	Fan Cover Screw (not shown)		1
	23011054-03	Capacitor	25uF, 250VAC	1
9	23011005	Rack		1
10	50102032	Hex Socket Cap Screw	M6x1.0x16	2
11	50201017	Nut	M8x1.25	2
12	50102021	Hex Cap Bolt	M8x1.25x30	2
13	23011055	Table		1
	23011056AW	Fence Assembly (includes #14,16,17,19,20)		1
14	23011056W	Fence		1
15	23011057	Hold Down		1
16	23011058	Hold Down Post		1
17	23011059	Fence Rod		1
18	50109001	Wing Screw	M8x1.25	1
19	TS-1523011	Set Screw	M6x1x6	2
20	50110005	Flat Head Screw	M6x1x22	1
21	23011009	Lock Handle	M8x1.25x30	1
22	23011010	Brass Screw	M8x1.25x25	1
23	23011061	Pinion Shaft		1
24	50605005	Key	5x5x14 mm	1
25	23011012	Collar		1
26	23011013	Gear		1
27	23011014	Lower Cylinder Fitting		1
28	23011030	Cylinder Head (re:23011031A)		1
29	23011031	Hydraulic Cylinder		1
	23011031A	Hydraulic Cylinder Assembly (includes #28,29)		1
30	23011062	Clutch Block		1
31	23011063	Spring		1
32	23011064	Washer		1
33	50110006	Flat Head Screw	M6x1x11	1
34	23011017	Upper Cylinder Fitting		1
35	23011065	Handle Rod		1
36	23011019	Handle Grip		1
37	50102042	Hex Socket Cap Screw	M5x0.8x16	3
38	23011020	Adapter		1
39	23011032	Chuck		1
40	23011033	Bushing	5/8"	1
41	23011034	Bushing	3/4"	1
42	23011021	Cap		1
43	50105006	Flat Head Screw	M6x1x20	2
44	23011066W	Right Side Cover Assembly		1
45	23011067W	Left Side Cover Assembly		1
46	50104010	Screw	M5x0.8x8	2
47	50104011	Screw	M5x0.8x12	2
48	50202006	Nut	M5x0.8	2
49	23011068	Spring		2
50	23011050	Switch Base		1
51	23011051	Switch Cover		1
52	23011029	Toggle Switch		1
53	50111002	Tap Screw	M10x2	2
54	23011026	Brass Pin		2

Index No.	Part No.	Description	Size	Qty
55	23011027	Spring		2
56	50103013	Set Screw	M10x1.5x20	2
57	50201014	Nut	M10x1.5	2
58	23011077	Key Clip		1
59	50322004	Spring Washer	M5	1
60	50102002	Hex Socket Cap Screw	M5x0.8x8	1
61	23011076	Chuck Key		1
	23010045	"JET" Label (not shown)		1



427 New Sanford Road
 LaVergne, Tennessee 37086
 Phone: 800-274-6848
www.jettools.com