



Operating Instructions and Parts Manual 14-inch Deluxe Pro Band Saw

Models: JWBS-14DXPRO



(Shown with optional Rip Fence)

JET
427 New Sanford Road
LaVergne, Tennessee 37086
Ph.: 800-274-6848
www.jettools.com



Part No. M-710116
Revision C1 10/2014
Copyright © 2014 JET

Warranty and Service

JET warrants every product it sells against manufacturers' defects. If one of our tools needs service or repair, please contact Technical Service by calling 1-800-274-6846, 8AM to 5PM CST, Monday through Friday.

Warranty Period

The general warranty lasts for the time period specified in the literature included with your product or on the official JET branded website.

- JET products carry a limited warranty which varies in duration based upon the product. (See chart below)
- Accessories carry a limited warranty of one year from the date of receipt.
- Consumable items are defined as expendable parts or accessories expected to become inoperable within a reasonable amount of use and are covered by a 90 day limited warranty against manufacturer's defects.

Who is Covered

This warranty covers only the initial purchaser of the product from the date of delivery.

What is Covered

This warranty covers any defects in workmanship or materials subject to the limitations stated below. This warranty does not cover failures due directly or indirectly to misuse, abuse, negligence or accidents, normal wear-and-tear, improper repair, alterations or lack of maintenance. JET woodworking machinery is designed to be used with Wood. Use of these machines in the processing of metal, plastics, or other materials may void the warranty. The exceptions are acrylics and other natural items that are made specifically for wood turning.

Warranty Limitations

Woodworking products with a Five Year Warranty that are used for commercial or industrial purposes default to a Two Year Warranty. Please contact Technical Service at 1-800-274-6846 for further clarification.

How to Get Technical Support

Please contact Technical Service by calling 1-800-274-6846. **Please note that you will be asked to provide proof of initial purchase when calling.** If a product requires further inspection, the Technical Service representative will explain and assist with any additional action needed. JET has Authorized Service Centers located throughout the United States. For the name of an Authorized Service Center in your area call 1-800-274-6846 or use the Service Center Locator on the JET website.

More Information

JET is constantly adding new products. For complete, up-to-date product information, check with your local distributor or visit the JET website.

How State Law Applies

This warranty gives you specific legal rights, subject to applicable state law.

Limitations on This Warranty

JET LIMITS ALL IMPLIED WARRANTIES TO THE PERIOD OF THE LIMITED WARRANTY FOR EACH PRODUCT. EXCEPT AS STATED HEREIN, ANY IMPLIED WARRANTIES OF MERCHANTABILITY AND FITNESS FOR A PARTICULAR PURPOSE ARE EXCLUDED. SOME STATES DO NOT ALLOW LIMITATIONS ON HOW LONG AN IMPLIED WARRANTY LASTS, SO THE ABOVE LIMITATION MAY NOT APPLY TO YOU.

JET SHALL IN NO EVENT BE LIABLE FOR DEATH, INJURIES TO PERSONS OR PROPERTY, OR FOR INCIDENTAL, CONTINGENT, SPECIAL, OR CONSEQUENTIAL DAMAGES ARISING FROM THE USE OF OUR PRODUCTS. SOME STATES DO NOT ALLOW THE EXCLUSION OR LIMITATION OF INCIDENTAL OR CONSEQUENTIAL DAMAGES, SO THE ABOVE LIMITATION OR EXCLUSION MAY NOT APPLY TO YOU.

JET sells through distributors only. The specifications listed in JET printed materials and on official JET website are given as general information and are not binding. JET reserves the right to effect at any time, without prior notice, those alterations to parts, fittings, and accessory equipment which they may deem necessary for any reason whatsoever. JET® branded products are not sold in Canada by JPW Industries, Inc.

Product Listing with Warranty Period

90 Days – Parts; Consumable items; Light-Duty Air Tools
1 Year – Motors; Machine Accessories; Heavy-Duty Air Tools; Pro-Duty Air Tools
2 Year – Metalworking Machinery; Electric Hoists, Electric Hoist Accessories; Woodworking Machinery used for industrial or commercial purposes
5 Year – Woodworking Machinery
Limited Lifetime – JET Parallel clamps; VOLT Series Electric Hoists; Manual Hoists; Manual Hoist Accessories; Shop Tools; Warehouse & Dock products; Hand Tools

NOTE: JET is a division of JPW Industries, Inc. References in this document to JET also apply to JPW Industries, Inc., or any of its successors in interest to the JET brand.

Table of Contents

Warranty and Service	2
Table of Contents	3
Shipping Contents	7
Contents of Shipping Containers	7
Container Two.....	7
Tools Required for Assembly.....	7
Fasteners for JWBS-14DXPRO.....	7
Assembly.....	8
Unpacking and Cleanup	8
Stand	8
Mounting the Trunnion Bracket to the Band Saw	8
Mounting the Table to the Bandsaw.....	9
Grounding Instructions.....	10
115 Volt Operation	10
230 Volt Conversion.....	10
Extension Cords.....	11
Adjustments.....	12
Tilting the Table.....	12
Adjusting 90° Table Stop.....	12
Changing Blades.....	13
Adjusting Blade Tension.....	14
Adjusting Blade Tracking.....	15
Adjusting Upper Blade Guide Assembly.....	15
Adjusting Upper Blade Guides and Thrust Bearings.....	16
Adjusting Lower Blade Guides and Thrust Bearings.....	16
Adjusting Guide Post Parallel To Blade	17
Changing Blade Speeds.....	17
Optional Accessories	18
Troubleshooting.....	18
Parts.....	18
Body Assembly (JWBS-14DXPRO)	19
Body Assembly (JWBS-14DXPRO)	20
Closed Stand Assembly (JWBS-14DXPRO)	24
Closed Stand Assembly (JWBS14-DXPRO)	25
Electrical Schematic – 115V	26
Electrical Schematic – 230V	27

Warnings

0. Read and understand the entire owner's manual before attempting assembly or operation.
1. Read and understand the warnings posted on the machine and in this manual. Failure to comply with all of these warnings may cause serious injury.
2. Replace the warning labels if they become obscured or removed.
3. This band saw is designed and intended for use by properly trained and experienced personnel only. If you are not familiar with the proper and safe operation of a band saw, do not use until proper training and knowledge have been obtained.
4. Do not use this band saw for other than its intended use. If used for other purposes, JET disclaims any real or implied warranty and holds itself harmless from any injury that may result from that use.
5. Always wear approved safety glasses/face shields while using this band saw. Everyday eyeglasses only have impact resistant lenses; they are not safety glasses.
6. Before operating this band saw, remove tie, rings, watches and other jewelry, and roll sleeves up past the elbows. Remove all loose clothing and confine long hair. Non-slip footwear or anti-skid floor strips are recommended. Do **not** wear gloves.
7. Always use the blade guard on all "through-sawing" operations. A through-sawing operation is one in which the blade cuts completely through the workpiece.
8. Some dust created by power sanding, sawing, grinding, drilling and other construction activities contain chemicals known to cause cancer, birth defects or other reproductive harm. Some examples of these chemicals are:
 - Lead from lead based paint.
 - Crystalline silica from bricks, cement and other masonry products.
 - Arsenic and chromium from chemically treated lumber.Your risk of exposure varies, depending on how often you do this type of work. To reduce your exposure to these chemicals, work in a well-ventilated area and work with approved safety equipment, such as face or dust masks that are specifically designed to filter out microscopic particles.
9. Do not operate this machine while tired or under the influence of drugs, alcohol or any medication.
10. Make certain the switch is in the **OFF** position before connecting the machine to the power supply.
11. Make certain the machine is properly grounded.
12. Make all machine adjustments or maintenance with the machine unplugged from the power source.
13. Remove adjusting keys and wrenches. Form a habit of checking to see that keys and adjusting wrenches are removed from the machine before turning it on.
14. Keep safety guards in place at all times when the machine is in use. If removed for maintenance purposes, use extreme caution and replace the guards immediately.
15. Make sure the band saw is firmly secured to the floor or bench before use.
16. Check damaged parts. Before further use of the machine, a guard or other part that is damaged should be carefully checked to determine that it will operate properly and perform its intended function. Check for alignment of moving parts, binding of moving parts, breakage of parts, mounting and any other conditions that may affect its operation. A guard or other part that is damaged should be properly repaired or replaced.
17. Provide for adequate space surrounding work area and non-glare, overhead lighting.
18. Keep the floor around the machine clean and free of scrap material, oil and grease.

Warnings

19. Keep visitors a safe distance from the work area. **Keep children away.**
20. Make your workshop child proof with padlocks, master switches or by removing starter keys.
21. Give your work undivided attention. Looking around, carrying on a conversation and “horse-play” are careless acts that can result in serious injury.
22. Maintain a balanced stance at all times so that you do not fall into the blade or other moving parts. Do not overreach or use excessive force to perform any machine operation.
23. Use the right tool at the correct speed and feed rate. Do not force a tool or attachment to do a job for which it was not designed. The right tool will do the job better and safer.
24. Use recommended accessories; improper accessories may be hazardous.
25. Maintain tools with care. Keep saw blades sharp and clean for the best and safest performance. Follow instructions for lubricating and changing accessories.
26. Make sure the work piece is held firmly against the rip fence or miter gauge as it is fed through the blade.
27. Turn off the machine before cleaning. Use a brush or compressed air to remove chips or debris — do not use your hands.
28. Do not stand on the machine. Serious injury could occur if the machine tips over.
29. Never leave the machine running unattended. Turn the power off and do not leave the machine until it comes to a complete stop.
30. Remove loose items and unnecessary work pieces from the area before starting the machine.

Familiarize yourself with the following safety notices used in this manual:

CAUTION This means that if precautions are not heeded, it may result in minor injury and/or possible machine damage.

WARNING This means that if precautions are not heeded, it may result in serious injury or possibly even death.

Specifications

Stock Number.....	710116K
Model Number.....	JWBS-14DXPro
Cutting Capacity (height).....	12"
Cutting Capacity (width).....	13-1/2"
Minimum Blade Width.....	1/8"
Maximum Blade Width.....	3/4"
Blade Length.....	105"
Blade Speed.....	1500 / 3000 SFPM
Table Size.....	15" x 15"
Table Slot Size.....	3/8"D x 3/4"W
Table Height from Floor.....	43-1/2"
Table Tilt (L-R).....	45°R / 10°
Dust Chute Diameter.....	4" O.D.
Overall Dimensions (without fence).....	77"H x 28"W x 29"D
Footprint Dimensions.....	17"W x 24"D
Motor.....	1.25 HP, 1Ph, 115/230V (prewired 115V)
Net Weight (approx.).....	247 lb.
Shipping Weight (approx.).....	258 lb.

The specifications in this manual are given as general information and are not binding. JET reserves the right to effect, at any time and without prior notice, alterations to parts, fittings, and accessory equipment deemed necessary for any reason whatsoever.

Shipping Contents

Open both shipping containers and check for shipping damage. Report any damage immediately to your distributor and shipping agent. Read the instruction manual thoroughly for assembly, maintenance and safety instructions.

Contents of Shipping Containers

Container One

- 1 Stand
- 1 Door
- 2 Stand Supports
- 1 Accessory Package

Container Two

- 1 Saw body w/ motor
- 1 Poly-V Belt
- 1 Trunnion support bracket
- 1 Table
- 2 Table lock knobs
- 1 Table pin
- 1 Table insert
- 1 Fastener package (see fastener page)
- 1 Instruction manual
- 1 Warranty card

Tools Required for Assembly

(2) 10mm and (2)13mm open end wrenches or adjustable wrenches

Fasteners for JWBS-14DXPRO

- 1 – M6x16 carriage bolt (4)
- 2 – M6x8 pan head screw (1)
- 3 – M6 hex nut (4)
- 4 – M8 lock washer (6)
- 5 – M8 flat washer (8)
- 6 – M8 hex nut(5)
- 7 – M8x40 hex cap screw (6)
- 8 – M8x80 hex cap screw (1)
- 9 – Lock Knob (2)
- 10 – Knob (1)
- 11 – 4mm hex wrench(1)
- 12 – 6mm T-handle hex wrench (1)

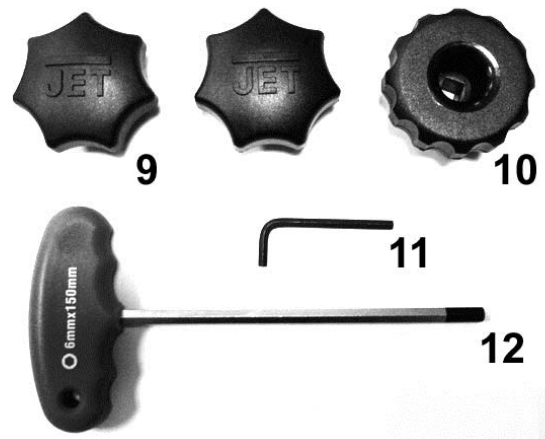
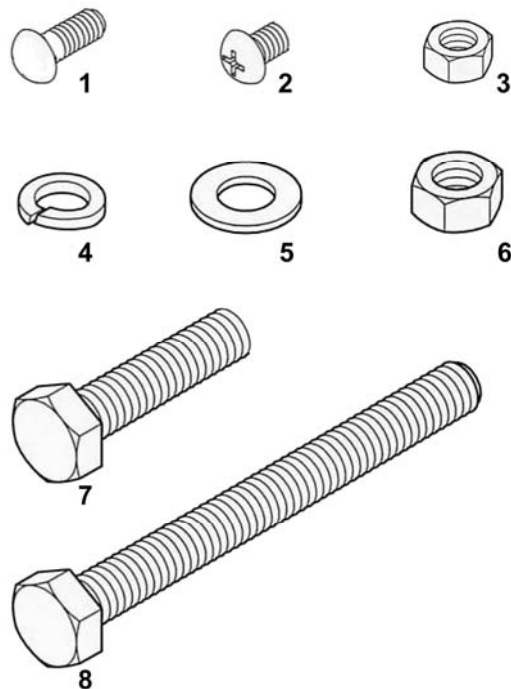

Assembly

⚠WARNING Read and understand all assembly instructions before attempting assembly! Failure to comply may cause serious injury!

Unpacking and Cleanup

1. Finish removing all contents from the shipping carton. Do not discard the carton or packing material until the band saw is assembled and is running satisfactorily.
2. Inspect the contents for shipping damage. Report damage, if any, to your distributor.
3. Compare the contents of the shipping carton with the contents list in this manual. Report shortages, if any, to your distributor.

Stand

Attach stand supports to back of cabinet BEFORE placing saw body on top of cabinet.

1. Using four M6x16 carriage bolts (C, Fig. 1) and four M6 nuts (B, Fig. 1) attach the stand supports (A, Fig. 1) through the saw cabinet. The bolt must be attached from the inside bottom of the saw cabinet (fig 1). To do this it is easiest if you tilt the saw cabinet on its front and then install the hardware.
2. Place cabinet stand upright on a level surface. If the surface is uneven then you should level the stand supports by loosening the nut (B, Fig 1) and moving the support up or down to prevent the stand from rocking, then tighten the nuts.

⚠WARNING Saw body is heavy! Use caution when lifting and stabilize until firmly attached to the stand! Failure to comply may cause serious injury!

3. With the aid of a second person, lift the saw body out of the shipping container and place onto stand top. Be sure front of saw (with JET logo) faces stand front (Door Side).
4. Line up holes in saw body with holes in the top of the stand. Fasten saw body to the stand with four M8 x 40 hex cap screws, eight M8 washers, four M8 lock washers, and four M8 hex nuts.

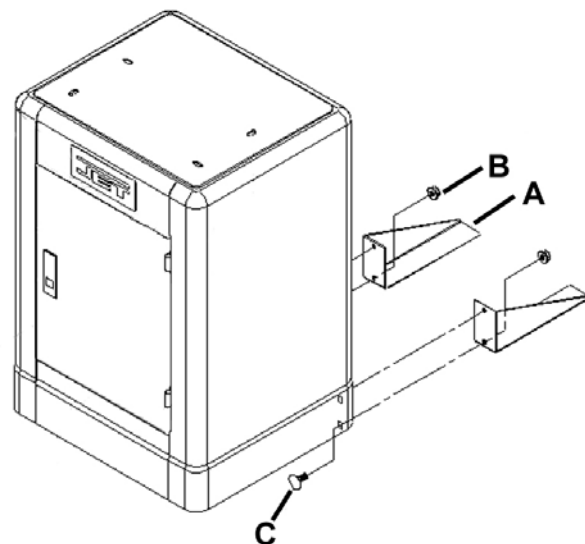

Figure 1

Mounting the Trunnion Bracket to

the Band Saw

1. Attach trunnion support to saw body with two M8 x 40 hex cap screws and two M8 lock washers. See Figure 2.
2. Thread nut on to table stop bolt (Fig. 2) and attach to trunnion support bracket as shown.

Once table is mounted to the trunnion bracket (see section below) and the blade is mounted in the saw (see section "Changing Blades") you may choose to fine tune the blade parallel to the miter slot. Using a square positioned in the miter slot, loosen screws shown in Figure 2 and lightly tap the table into position so the blade is parallel with the miter slot. Then gently tighten down the screws. This adjustment will ensure square cuts when using a miter gauge. This adjustment will NOT correct drift of a blade when ripping with a rip fence.

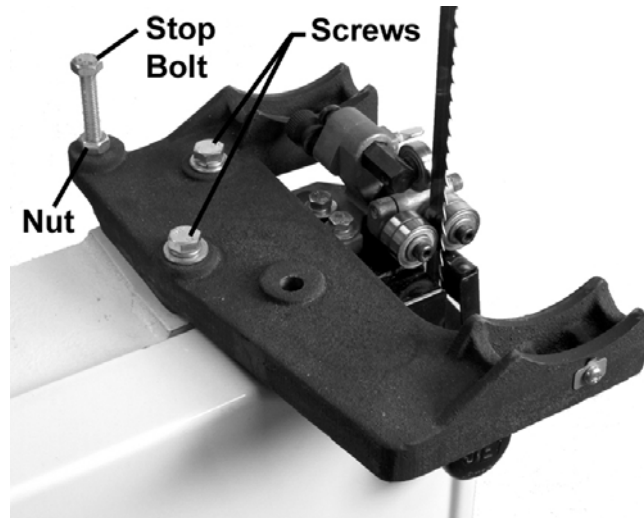

Figure 2

Mounting the Table to the Bandsaw

1. To mount the table, remove pin and insert from the table (Fig. 3).
2. Rotate the table so that the saw blade will slide through the slot in the table. Then orient the table so the screws will slide into the holes on the trunnion support bracket. Attach lock knobs to these screws (Fig. 3)
3. Replace pin and insert.

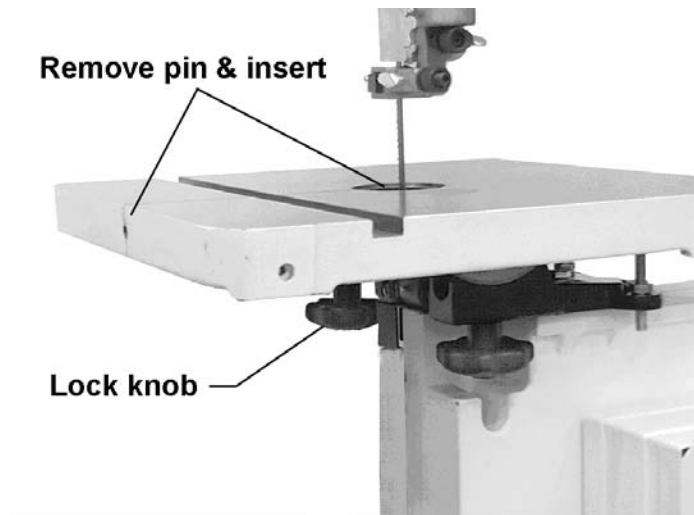

Figure 3

Grounding Instructions

⚠ WARNING This Band Saw must be grounded while in use to protect the operator from electric shock.

In the event of a malfunction or breakdown, grounding provides a path of least resistance for electric current to reduce the risk of electric shock. This tool is equipped with an electric cord having an equipment-grounding conductor and a grounding plug that looks similar to the plug in Figure 20. The plug must be inserted into a matching outlet that is properly installed and grounded in accordance with all local codes and ordinances.

Do not modify the plug provided. If it will not fit the outlet, have the proper outlet installed by a qualified electrician.

Improper connection of the equipment-grounding conductor can result in a risk of electric shock. The conductor, with insulation having an outer surface that is green with or without yellow stripes, is the equipment-grounding conductor. If repair or replacement of the electric cord or plug is necessary, do not connect the equipment-grounding conductor to a live terminal.

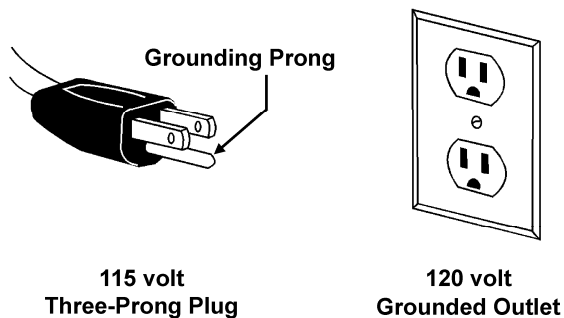

Figure 20

Check with a qualified electrician or service personnel if the grounding instructions are not completely understood, or if in doubt as to whether the tool is properly grounded.

Repair or replace a damaged or worn cord immediately.

115 Volt Operation

As received from the factory, your bandsaw is ready to run at 115-volt operation. This bandsaw, when wired for 115 volts, is intended for use on a circuit that has an outlet and a plug that looks like the one illustrated in Figure 20. A temporary adapter, like the adapter in Figure 21, may be used to connect this plug to a two-pole receptacle, as shown in Figure

21, if a properly grounded outlet is not available. The temporary adapter should only be used until a properly grounded outlet can be installed by a qualified electrician. This adapter is not applicable in Canada. The green colored rigid ear, lug, or tab, extending from the adapter, must be connected to a permanent ground such as a properly grounded outlet box, as shown in Figure 21.

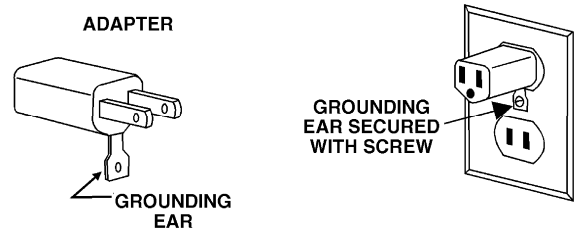

Figure 21

230 Volt Conversion

If 230V, single-phase operation is desired, the following instructions must be followed:

Disconnect machine from power source.

This band saw is supplied with four motor leads that are connected for 115V operation, as shown in Figure 22. Reconnect these four motor leads for 230V operation, as shown in Figure 22.

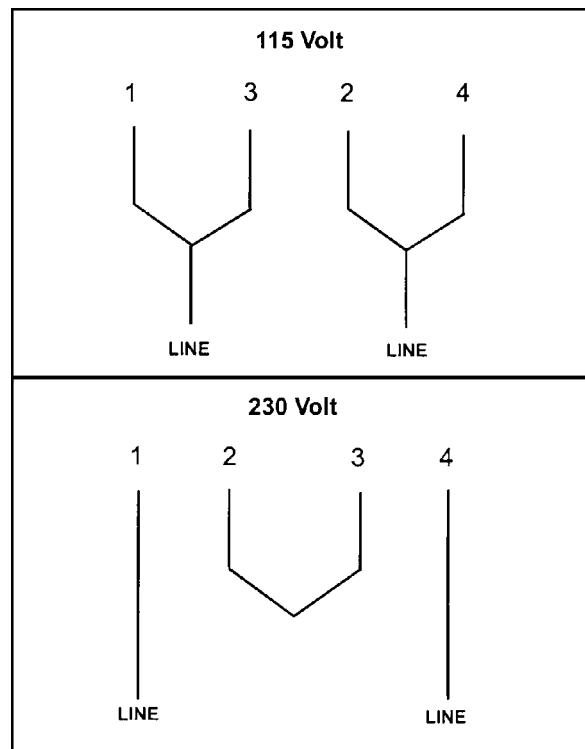

Figure 22

The 115V attachment plug supplied with the band saw must be replaced with a UL/CSA listed plug suitable for 230V operation, as shown in Figure 23. Contact your local authorized JET service center or qualified electrician for proper procedures to install the plug. The band saw must comply with all local and national codes after the 230-volt plug is installed.

The band saw with a 230-volt plug should only be connected to an outlet having the same configuration (Figure 23). No adapter is available or should be used with the 230-volt plug.

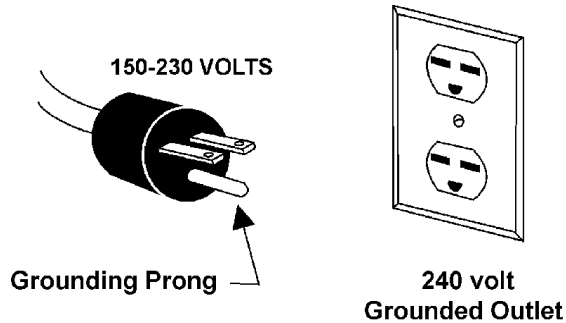

Figure 23

Important: In all cases (115 or 230 volts), make certain the receptacle in question is properly grounded. If you are not sure, have a registered electrician check the receptacle.

Extension Cords

Use only three wire extension cords that have three-prong grounding plugs and three-pole receptacles that accept the tool's plug.

Make sure the cord is in good condition, and heavy enough to carry the current your band saw will draw. An undersized cord will cause a drop in line voltage, resulting in loss of power and overheating. Table 1 shows the correct size to use depending on cord

length and the ampere rating on your machine's nameplate. If in doubt, use the next heavier gauge. The smaller the gauge number, the heavier the cord.

Repair or replace a damaged or worn cord immediately.

Power		Extension Cord	
Current (Amps)	Line voltage	Cord length in feet	Cord gauge (AWG)
0-6	120	0 to 25	18
		25 to 50	16
		50 to 100	16
		over 100	14
6-10	120	0 to 25	18
		25 to 50	16
		50 to 100	14
		over 100	12
10-12	120	0 to 25	16
		25 to 50	16
		50 to 100	14
		over 100	12
12-16	120	0 to 25	14
		25 to 50	12
		over 50	not recommended

Table 1

Adjustments

Tilting the Table

⚠WARNING Unplug the machine from the power source before making any repair or adjustment!

Failure to comply may cause serious injury!

1. Loosen two lock knobs (Fig. 4).
2. Tilt table up to 45 degrees to the right or down 10 degrees to the left, using the scale mounted to the trunnion.
3. Tighten two lock knobs (Fig.4).

Note: Table stop can be removed or further adjusted to tilt table to the left.

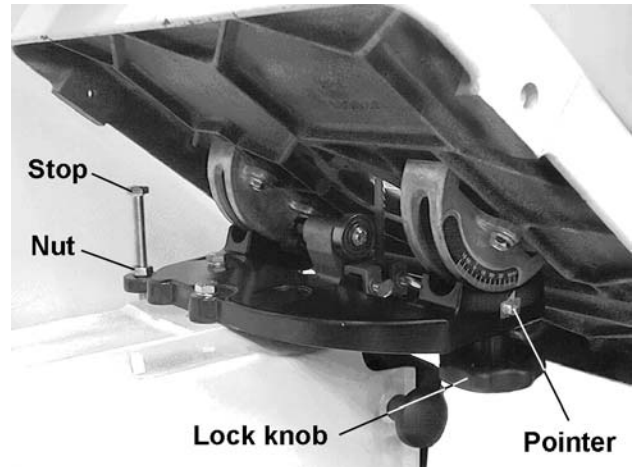

Figure 4

Adjusting 90° Table Stop

⚠WARNING Disconnect machine from the power source.

1. Loosen lock knobs (Fig. 4) and tilt table left until it rests against table stop.
2. Tighten Lock knobs
3. Use a square placed on the table and against the blade (Fig. 5) to see if the table is 90 degrees to the blade.
4. If an adjustment is necessary, loosen lock knobs, tilt table to the right, and lock in place.
5. Loosen jam nut and turn table stop (Fig. 4) left or right to raise or lower the stop. Tighten jam nut to hold table stop in place.
6. Unlock table, tilt back onto table rest and confirm table is 90 degrees with the blade.
7. If necessary, adjust scale pointer to zero.

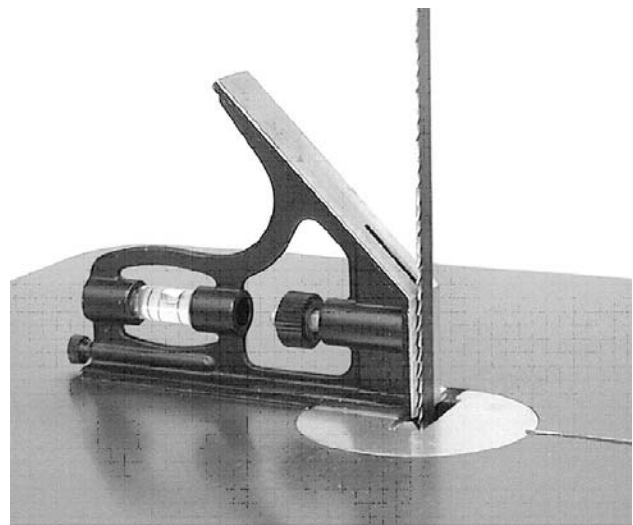

Figure 5

Changing Blades

⚠WARNING Blade teeth are sharp! Use care when handling the saw blade.

Failure to comply may cause serious injury!

1. Disconnect machine from power source.
2. Loosen blade tension by pushing up on the release lever (Fig. 6).
3. Remove the table insert and the table pin.
4. Open both wheel covers.
5. Back off the Thrust Bearing and both the upper and lower guide bearings from the blade.
6. Remove the blade from between upper and lower blade guides. Remove blade from upper and lower wheels. Turn blade to direct through slot in table.
7. Before mounting blade make sure the orientation of the blade is so the teeth are pointing down. If holding blade in front of you, as if mounted in the saw, the teeth should point down on right side of the loop. If not the blade is inside out. Twist the blade right side in to correct this, wear heavy gloves when doing so.
8. Guide new blade through table slot. Place blade in upper and lower blade guides.
9. Place blade in the middle of the upper and lower wheel.
10. Replace table insert and table pin.

Tension and track blade before operating saw. Review instructions for tensioning and tracking the blade under "Adjusting Blade Tension" and "Adjusting Blade Tracking".

Set thrust bearing and both upper and lower guide bearings. Review instructions for setting the upper and lower guider bearings under "Adjusting Upper Blade Guide and Blade Thrust Bearings" and "Adjusting Lower Blade Guide and Blade Thrust Bearings"

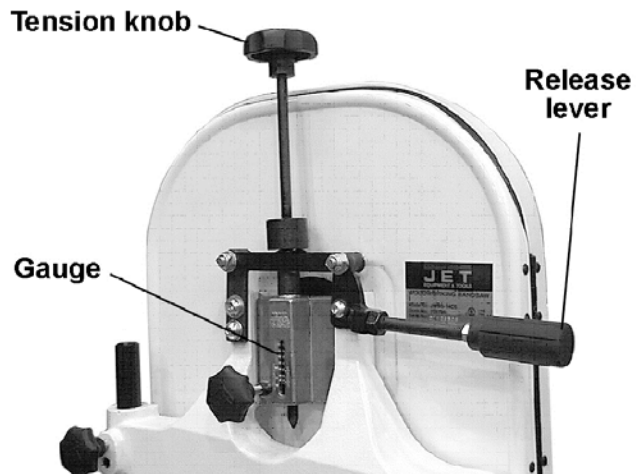

Figure 6

Adjusting Blade Tension

1. Disconnect machine from power source.
2. Make sure the blade is tensioned with the release lever in the down position as seen in Fig. 7.
3. Turn blade tension knob (Fig. 6) clockwise to tension blade. The blade width gauge (D, Fig. 8) indicates the approximate tension according to the width of the blade. Initially, set the blade tension to correspond to blade width*.
4. As you become familiar with the saw, you may find it necessary to change the blade tension from the initial setting. Changes in blade width and the type of material being cut will have an effect on blade tension.
5. Keep in mind that too little or too much blade tension can cause blade breakage.
6. If the blade will not tension correctly once the blade tensioner and tension knob are properly set then you may need to adjust the blade tensioning device.
7. Using a 2.5mm hex wrench loosen the set screw (B, Fig. 8) in the lower bushing (C, Fig. 8).
8. Using a pair of pliers rotate the bushing (C, Fig. 8) down only about 1 to 2 turns.
9. Replace the set screw (B, Fig. 8) and check for proper tension. Repeat the process if necessary.

*Note: When changing blades from a wider blade to a narrower blade that you should adjust the blade tension down to the appropriate width of the new blade. (use blade width gauge) BEFORE disengaging (up position) the blade release lever. Now you may proceed with the standard method of blade changing (See "Changing Blades" pg 14).

Failure to do so will result in over-tensioning the blade and possible blade breakage or even personal injury.

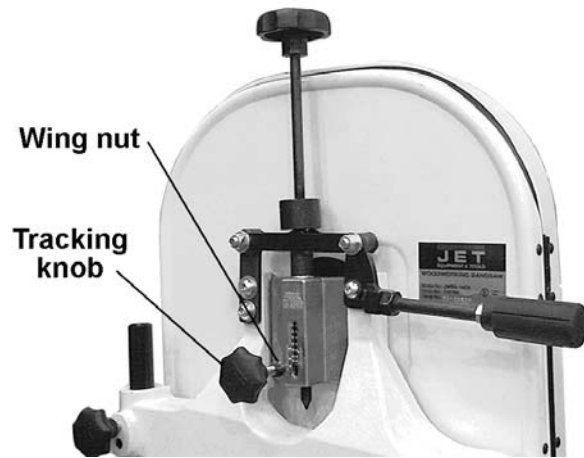

Figure 7

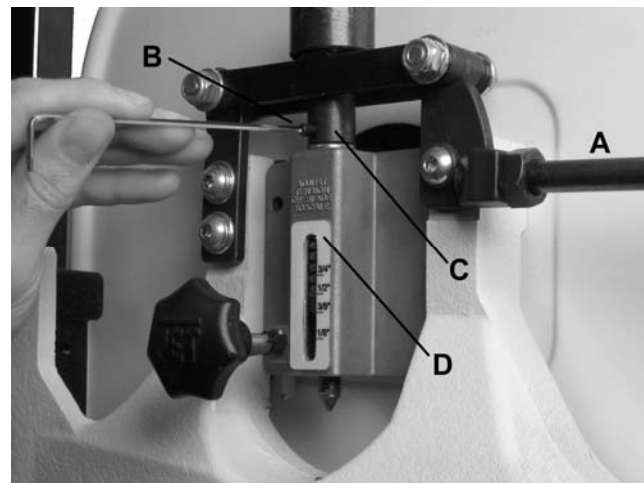

Figure 8

Adjusting Blade Tracking

⚠WARNING Disconnect machine from the power source! Never adjust blade tracking with the machine running!

Failure to comply may cause serious injury!

“Tracking” refers to how the blade is situated upon the wheels while in motion. The blade should track in the center of both wheels.

1. The blade must be properly tensioned before adjusting blade tracking. The release lever should be in the down (tensioned) position. Make sure blade guides and blade bearings do not interfere with the blade.
2. Open top blade cover. Rotate the wheel forward and observe the position of the blade on the wheel - it should be in the center of the wheel. See Fig. 9.
3. If adjustment is necessary, loosen wing nut (Fig. 7), and tighten tracking knob slightly to move blade toward rear of machine. Slightly loosening the tracking knob will cause the blade to track toward the front of the machine.
4. Tighten wing nut after blade is tracking in the center of the wheel.

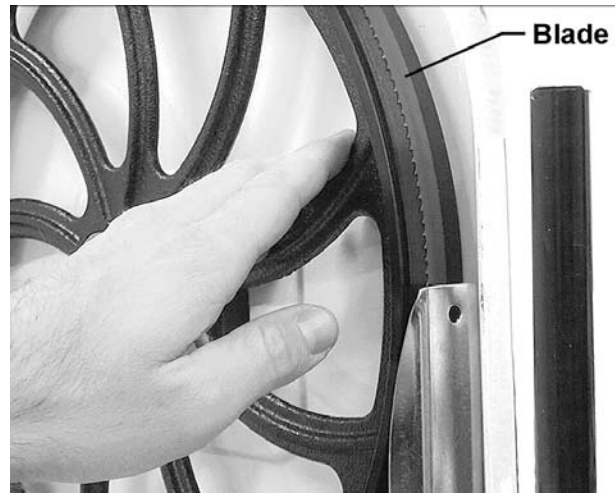

Figure 9

Adjusting Upper Blade Guide Assembly

⚠WARNING Blade guard has been removed for picture clarity. Never operate the bandsaw without all guards in place and in working order!

Failure to comply may cause serious injury!

1. Disconnect machine from the power source.
2. Loosen lock knob (C, Fig. 10) and raise or lower upper blade guide assembly (B, Fig. 10) by turning knob (A, Fig. 10) to just above the material being cut.
3. Tighten lock knob. Make sure blade guide bearings (D, Fig. 10) are still aligned next to the blade. If adjustment is necessary, review “Adjusting Upper Blade Guides and Thrust Bearings” section of manual.

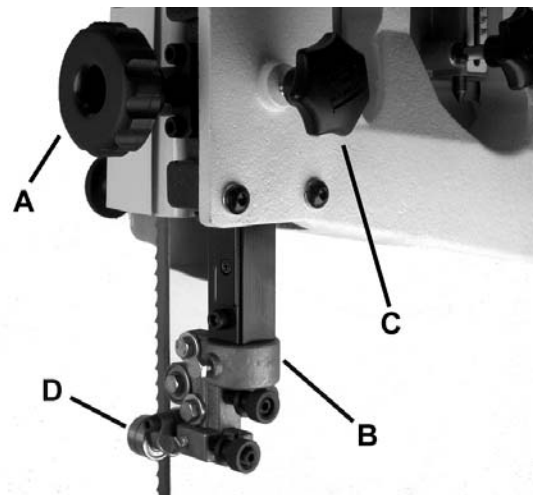

Figure 10

Adjusting Upper Blade Guides and Thrust Bearings

⚠WARNING Blade guard has been removed for picture clarity. Never operate the bandsaw without all guards in place and in working order!

Failure to comply may cause serious injury!

1. Disconnect machine from the power source.
2. Blade must already be tensioned and tracking properly.
3. Loosen thumb screw (F, Fig. 11) and turn knurled knob (E, Fig. 11) to move the thrust bearing (G, Fig. 10) in or out until the bearing is 1/64" behind blade.
4. Tighten thumb screw (F, Fig. 11).
5. Loosen thumb screw (C, Fig. 11) and turn knurled knob (D, Fig. 11) to move the guide block bracket in or out until the front edge of the guide bearings are just behind the "gullets" of the saw teeth.
6. Tighten thumb screw (C, Fig. 11).
7. Loosen locking bolt (B, Fig. 11) and rotate guide bearings (A Fig 11) using cam (H, Fig. 11) with provided 4mm hex wrench as close to the blade as possible without pinching it.
8. Tighten locking bolt (B, Fig. 11).

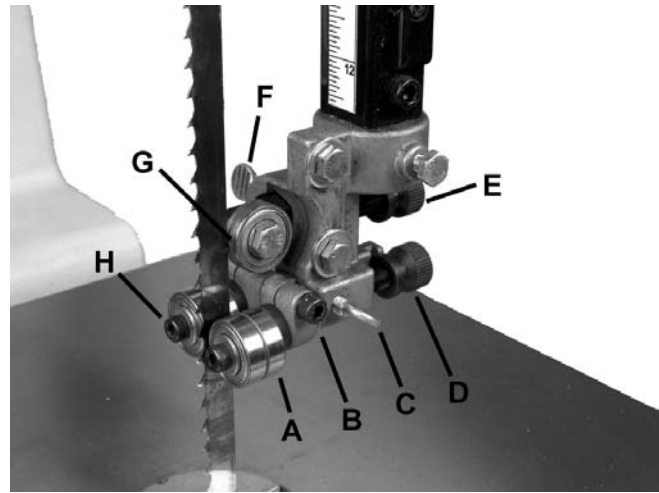

Figure 11

Adjusting Lower Blade Guides and Thrust Bearings

⚠WARNING Table Removed For Clarity. Never operate the bandsaw without a table secured in place.

1. Disconnect machine from the power source.
2. Blade must be tensioned and tracking properly.
3. Loosen thumb screw (G, Fig. 12) and turn knurled knob (F, Fig. 12) to move the thrust bearing (H, Fig. 12) in or out until the bearing is 1/64" behind blade.
4. Tighten thumb screw (G, Fig. 12).
5. Loosen thumb screw (D, Fig. 12) and turn knurled knob (E, Fig. 12) to move the guide block bracket in or out until the front edge of the guide bearings are just behind the "gullets" of the saw teeth.
6. Tighten thumb screw (D, Fig. 12).
7. Loosen lock bolt (C, Fig. 12) and rotate guide bearings (B, Fig. 12) using cam (A, Fig. 12) with provided 4mm hex wrench as close to blade as possible without pinching it.
8. Tighten lock bolt (C, Fig. 12).

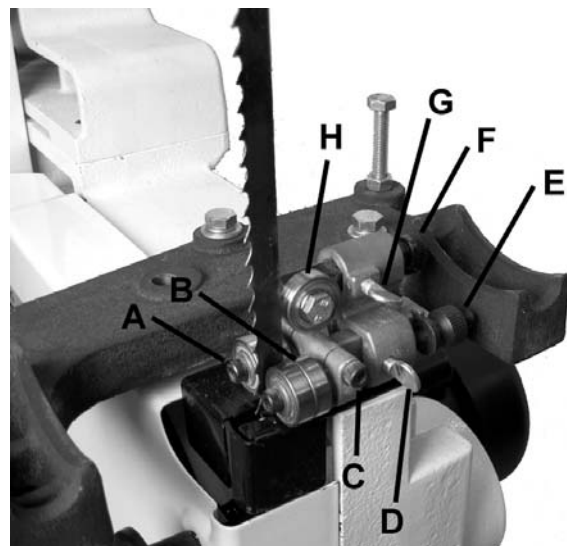

Figure 12

Adjusting Guide Post Parallel To Blade

1. Verify guide post is parallel to blade by checking position of bearings with respect to blade when the guide post is raised all the way up and again in the lowest position.
2. If the bearings have shifted throughout the travel of the guide post then it needs to be adjusted.
3. If adjustment needs to be made left and right, slightly loosen the four bolts (A, Fig 12a) and make slight guide post adjustments as needed. Tighten bolts when completed.
4. If adjustment needs to be made forward and aft, adjustment is made by tightening and loosening the set screws (B, C, Fig 12a). The top set screws (B, Fig 12a) adjust the guide post back (when standing in front of saw), while the bottom set screws (C, Fig 12a) will adjust the guide post forward.

Changing Blade Speeds

⚠WARNING Lower door removed for clarity. Never operate bandsaw without door installed and closed.

1. Disconnect machine from the power source.
2. Open the lower door and locate the locking bolt (A Fig. 13). Loosen bolt using the provided 6mm T-handle hex wrench.
3. Rotate motor so the belt slackens.
4. Tighten locking bolt (A, Fig. 13) to keep motor fixed and prevent from pinching fingers.
5. Move belt from one pulley to the next. The belt needs to be moved on BOTH idler pulley (C Fig. 13) and motor pulley (B Fig. 13). The belt should NOT be twisted across the pulleys.*
6. Repeat steps 1-4 in reverse to tension belt.**

*: When the belt is set closer to the back of the saw body it is set for 3000 SFPM speed, further away is 1500 SFPM speed.

** : Tensioning the belt can be acquired by pulling the motor back with one hand and tightening the locking bolt with the T-handle hex wrench with the other. Excessive force is NOT needed to properly tension belt.

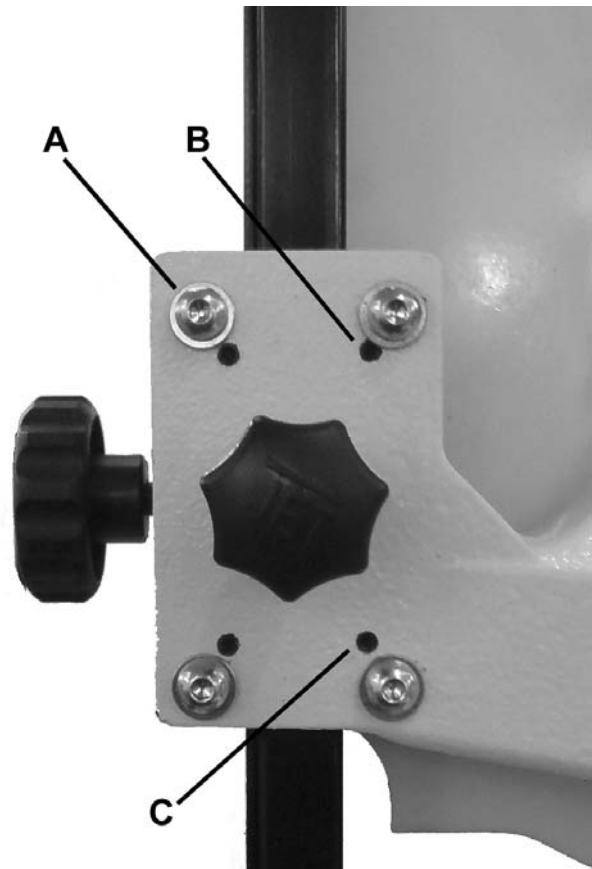

Figure 12a



Figure 13

Optional Accessories for JWBS-14DXPRO Band Saw

708718R JRF-14 Rip Fence Assembly
Includes guide bars, rip fence assembly, fasteners, and mounting instructions with parts list.

708716 JMG-14 Miter Gauge Assembly
For straight and angle cutting. Includes guide bar, pivoting support body, and adjustable stops.

Troubleshooting (JWBS-14DXPRO Band Saw)

PROBLEM	POSSIBLE CAUSE	SOLUTION
Saw stops or will not start	<ol style="list-style-type: none">1. Saw unplugged2. Fuse blown or circuit breaker tripped3. Cord damaged	<ol style="list-style-type: none">1. Check plug connections2. Replace fuse or reset circuit breaker3. Replace cord
Does not make accurate 45 deg. or 90 deg. cuts	<ol style="list-style-type: none">1. Stop not adjusted correctly2. Angle pointer not set accurately3. Miter gauge out of adjustment	<ol style="list-style-type: none">1. Check blade with square and adjust stop2. Check blade with square and adjust pointer3. Adjust miter gauge
Blade wanders during cut	<ol style="list-style-type: none">1. Fence not aligned with blade2. Warped wood3. Excessive feed rate4. Incorrect blade for cut5. Blade tension not set properly6. Guides not set properly	<ol style="list-style-type: none">1. Check and adjust fence2. Select another piece of wood3. Reduce feed rate4. Change blade to correct type5. Set blade tension according to blade size6. Adjust guides
Saw makes unsatisfactory cuts	<ol style="list-style-type: none">1. Dull blade2. Blade mounted wrong3. Gum or pitch on blade4. Incorrect blade for cut5. Gum or pitch on table	<ol style="list-style-type: none">1. Replace blade2. Teeth should point down3. Remove blade and clean4. Change blade to correct type5. Clean table
Blade does not come up speed	<ol style="list-style-type: none">1. Extension cord too light or too long2. Low shop voltage	<ol style="list-style-type: none">1. Replace with adequate size and to length cord2. Contact your local electric company
Saw vibrates excessively	<ol style="list-style-type: none">1. Base on uneven floor2. Bad Poly-V belt3. Motor mount is loose4. Loose hardware	<ol style="list-style-type: none">1. Reposition on flat, level surface2. Replace Poly-V belt3. Tighten motor mount hardware4. Tighten hardware

Parts

Ordering Replacement Parts

To order parts or reach our service department, call 1-800-274-6848 Monday through Friday (see our website for business hours, www.jettools.com). Having the Model Number and Serial Number of your machine available when you call will allow us to serve you quickly and accurately.

Body Assembly (JWBS-14DXPRO)

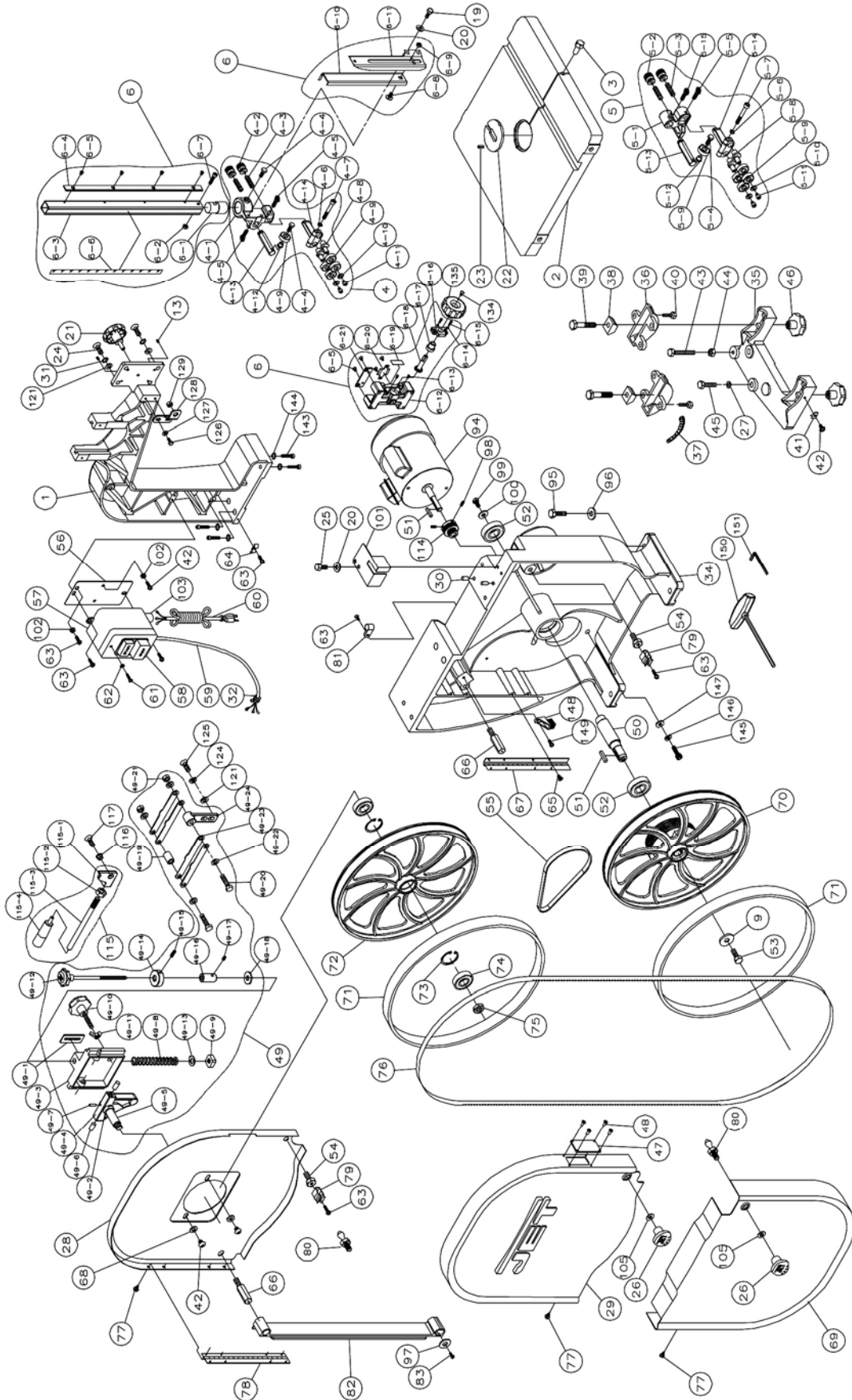

Body Assembly (JWBS-14DXPRO)

Index No	Part No	Description	Size	Qty
1	JWBS14DP-1	Upper Arm Frame		1
2	150037W	Table		1
3	100038	Table Pin		1
4	JWBS14DP-4	Upper Support & Blade Guide Assembly		1
4-1	PWBS14-226	Upper Support Bracket		1
4-2	150010A	Adjusting Nut		2
4-3	JWBS14DP-4-3	Socket Set Screw	M8x35	2
4-4	TS-1482041	Hex Cap Screw	M6x20	2
4-5	150013A	Thumb Screw	M6x16	2
4-6	TS-2361051	Lock Washer	M5	1
4-7	TS-1502091	Socket Head Cap Screw	M5x40	1
4-8	PWBS14-240	Eccentric Shaft		2
4-9	BB-608ZZ	Ball Bearing	608ZZ	5
4-10	TS-1550031	Flat Washer	M5	2
4-11	TS-1502031	Socket Head Cap Screw	M5x12	2
4-12	PWBS14-231	Bearing Sheath		1
4-13	PWBS14-230	Spacing Sleeve		1
4-14	PWBS14-239	Support Bracket		1
5	JWBS14DP-5	Lower Support & Blade Guide Assembly		1
5-1	PWBS14-241	Lower Support Bracket		1
5-2	150010A	Adjusting Nut		2
5-3	JWBS14DP-4-3	Socket Set Screw	M8x35	2
5-4	TS-1482041	Hex Cap Screw	M6x20	1
5-5	150013A	Thumb Screw	M6x16	1
5-6	TS-2361051	Lock Washer	M5	1
5-7	TS-1502091	Socket Head Cap Screw	M5x40	1
5-8	PWBS14-240	Eccentric Shaft		2
5-9	BB-608ZZ	Ball Bearing	608ZZ	5
5-10	TS-1550031	Flat Washer	M5	2
5-11	TS-1502031	Socket Head Cap Screw	M5x12	2
5-12	PWBS14-231	Bearing Sheath		1
5-13	PWBS14-230	Spacing Sleeve		1
5-14	PWBS14-239	Support Bracket		1
5-15	150014A	Thumb Screw	M6x12	1
6	JWBS14DP-6	Guide Post & Bracket Assembly		1
6-2	TS-1540021	Hex Nut	M4	1
6-3	150144	Guide Post		1
6-4	JWBS14DP-6-4	Rack		1
6-5	JWBS14DP-6-5	Flat Head Machine Screw	M4x5	10
6-6	JWBS14DP-6-6	Scale		1
6-7	TS-1532032	Pan Head Screw	M4x10	1
6-8	JWBS14DP-6-8	Carriage Bolt	M8x16	1
6-9	TS-1541031	Nylon Insert Lock Nut	M8	1
6-10	JWBS14DP-6-10	Upper Wheel Blade Guard Extension		1
6-11	JWBS14DP-6-11	Upper Wheel Blade Guard		1
6-12	JWBS14DP-6-12	Upper Support Bracket		1
6-13	TS-1523011	Set Screw	M6x6	2
6-14	TS-2361061	Lock Washer	M6	2
6-15	TS-1503021	Socket Head Cap Screw	M6x10	2
6-16	JWBS14DP-6-16	Cover		1
6-17	JWBS14DP-6-17	Bushing		1
6-18	JWBS14DP-6-18	Pinion Gear		1
6-19	JWBS14DP-6-19	Spacer		1
6-20	JWBS14DP-6-20	Spring Piece		1
6-21	JWBS14DP-6-21	Pad		2
9	TS-1550061	Flat Washer	M8	1
13	TS-1523021	Socket Head Set Screw	M6x8	4
19	TS-1482011	Hex Cap Screw	M6x8	2
20	TS-1550041	Flat Washer	M6	4

Index No	Part No	Description	Size	Qty
21	JWBS14DP-21	Locking Knob	M8x25	1
22	199037	Table Insert		1
23	992311	Spring Pin	Ø3x8	1
24	TS-2248252	Button Head Socket Screw	M8x25	4
25	TS-1482041	Hex Cap Screw	M6x20	2
26	150024	Knob		2
27	TS-2361081	Lock Washer*	M8	2
28	JWBS14DP-28	Inner Wheel Cover		1
29	JWBS14DP-29	Outer Wheel Cover		1
	JWBS14DP-29A	Outer Wheel Cover Assembly (Index #29, #47, #48)		1
30	150031	Pin	Ø6.35x16	2
31	TS-2361081	Lock Washer	M8	4
32	998623	Strain Relief		1
34	JWBS14DP-34	Base		1
35	PWBS14-150	Trunnion Support Bracket		1
36	100042	Trunnion		2
37	100051	Scale		1
38	100041	Trunnion Clamp Shoe		2
39	TS-1491081	Hex Cap Screw	M10x50	2
40	TS-1482021	Hex Cap Screw	M6x12	6
41	110049	Pointer		1
42	990821	Pan Head Screw	M5x6	5
43	TS-1490151	Hex Cap Screw*	M8x80	1
44	TS-1540061	Nut*	M8	1
45	TS-1490071	Hex Cap Screw*	M8x40	2
46	990554	Lock Knob		2
47	JWBS14DP-47	Blade Tracking Window		1
48	JWBS14DP-48	Rivet	Ø3.2x10	4
49	JWBS14DP-49	Sliding Bracket Assembly		1
49-1	JWBS14DP-49-1	Scale		1
49-2	JWBS14DP-49-2	Bolt Ring		1
49-3	JWBS14DP-49-3	Sliding Bracket		1
49-4	JWBS14DP-49-4	Shaft Hinge		1
49-5	JWBS14DP-49-5	Upper Wheel Shaft		1
49-6	100021	Steel Pin		2
49-7	992314	Spring Pin		1
49-8	JWBS14DP-49-8	Coil Spring		1
49-9	150090	Square Nut		1
49-10	990652	Lock Knob		1
49-11	NW080000	Wing Nut	M8	1
49-12	JWBS14DX-193	Blade Adjusting Screw		1
49-13	150260	Indicator		1
49-14	100174	Fixed Collar		1
49-15	TS-1522031	Socket Set Screw	M5x10	1
49-16	130044	Fixed Collar		1
49-17	SS050100	Socket Set Screw	M5x5	1
49-18	TS-1550071	Flat Washer	M10	1
49-19	100177	Spacer		1
49-20	TS-1490071	Hex Cap Screw	M8x40	2
49-21	TS-1541031	Nylon Insert Lock Nut	M8	2
49-22	TS-1550061	Flat Washer	M8	4
49-23	100178	Support Plate		4
49-24	100179	Fixed Base		1
50	JWBS14DP-50	Lower Wheel Shaft		1
51	6291489	Key	5x5x20	2
52	BB-6204VV	Ball Bearing	6204LLU	2
53	990293	Hex Head Bolt (Left Thread)	M8x25	1
54	150054	Hex Head Bolt		2
55	JWBS14DP-55	Poly V-Belt	200J5	1
56	JWBS14DP-56	Switch Backing Plate		1
57	523028	Switch Box		1

Index No	Part No	Description	Size	Qty
58	994542	Switch		1
59	JWBS14DP-59	Motor Cord		1
60	JWBS14DP-60	Power Cord		1
61	990814	Self Tapping Screw	M3.5x19	2
62	TS-1550021	Flat Washer	M4	2
63	TS-1533042	Phillips Pan Head Machine Screw	M5x12	7
64	523024	Wire Clip		1
65	TS-1533032	Phillips Pan Head Machine Screw	M5x10	4
66	150066	Stud		2
67	150902	Lower Hinge		1
68	TS-1550031	Flat Washer	M5	2
69	JWBS14OS-148	Lower Wheel Guard		1
70	JWBS14DP-70	Lower Wheel Assembly		1
71	100025A	Tire		2
72	100186	Upper Wheel		1
73	992522	Retaining Ring	R35	2
74	BB-6202VV	Ball Bearing	6202LLB	2
75	TS-1540083	Hex Nut	M12x1.25	1
76	JWBS14DP-76	Saw Blade	105"Lx3/8"Wx6TPI	1
77	990804	Self Tapping Screw	M4x8	12
78	150901	Upper Hinge		1
79	150079	Catch		2
80	170080	Latch Stud		2
81	998626	Cord Clamp		1
82	110070	Blade Guard		1
83	990811	Self Tapping Screw	M3.5x12	2
94	JWBS14DP-94	Motor	1-1/4HP, 1Ph, 115/230V1	
	JWBS14DP-94-MF	Motor Fan (not shown)		1
	JWBS14DP-94-MFC	Motor Fan Cover (not shown)		1
	JWBS14DP-94-SC	Start Capacitor (not shown)	200MFD, 125VAC	1
	JWBS14DP-94-RC	Run Capacitor (not shown)	30µF, 250 VAC	1
95	TS-1490071	Hex Cap Screw*	M8x40	4
96	TS-1550061	Flat Washer*	M8	4
97	150097	Oblong Washer		2
98	TS-1523051	Socket Set Screw	M6x16	2
99	TS-1490021	Hex Cap Screw	M8x16	1
100	TS-1550061	Flat Washer	M8	1
101	150101	Lower Wheel Blade Guard		1
102	WE050000	Star Washer	M5	3
103	998654	Strain Relief		2
105	WI080000	Star Washer	M8	2
114	JWBS14DP-114	Motor Pulley		1
115	JWBS14DP-115	Tension Lever Assembly		1
115-1	100182	Tension Lever		1
115-2	TS-1540081	Hex Nut	M12	1
115-3	100183	Tension Lever Rod		1
115-4	100234	Tension Lever Knob	M8	1
116	100176	Bushing		1
117	TS-2248202	Button Head Socket Screw	M8x20	1
121	TS-1550061	Flat Washer	M8	6
124	TS-2361081	Lock Washer	M8	2
125	TS-2248202	Button Head Socket Screw	M8x20	2
126	TS-1482021	Hex Cap Screw	M6x12	2
127	TS-1550041	Flat Washer	M6	2
128	JWBS14DP-128	Plate		1
129	TS-1540071	Nut	M10	1
134	JWBS14DP-134	Phillips Pan Head Machine Screw*	M6x8	1
135	JWBS14DP-135	Knob		1
143	TS-1505041	Socket Head Cap Screw	M10x30	4
144	TS-2361101	Lock Washer	M10	4
145	TS-1504051	Socket Head Cap Screw	M8x25	2

Index No	Part No	Description	Size	Qty
146	TS-2361081	Lock Washer	M8	2
147	TS-1550061	Flat Washer	M8	2
148	PWBS14-139	Wheel Brush		1
149	TS-1533042	Phillips Pan Head Machine Screw	M5x12	1
150	JWBS14DP-150	T-Handle Hex Wrench	6mm	1
151	TS-152705	Hex Wrench	4mm	1
	JWBS14DP-HK	Hardware Kit (not shown)		1

Note: * represents items included in JWBS14DP-HK Hardware Kit. In addition to these marked with *, it also includes Index #12, #13, #14 as shown in Stand Assembly Drawing/Parts List.

Closed Stand Assembly (JWBS-14DXPRO)

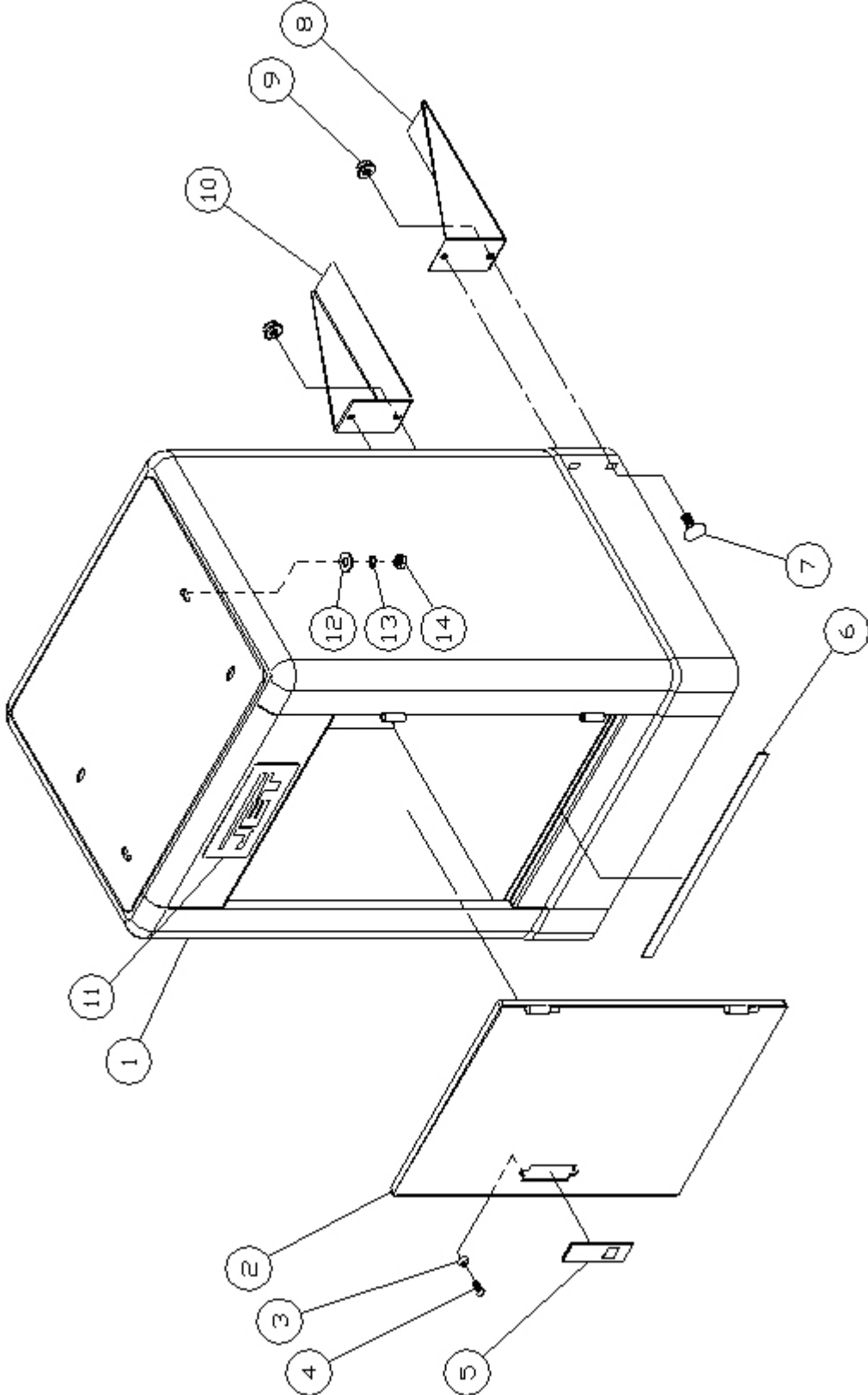

Closed Stand Assembly (JWBS14-DXPRO)

Index No	Part No	Description	Size	Qty
1	JWBS14DP-201	Stand		1
2	150502W	Door		1
3	WBS14CS-04	Washer		2
4	WBS14CS-05	Pan Head Screw	M4x5	2
5	150503	Door Latch Assembly		1
6	150527	Pad		2
7	JWBS14DP-207	Carriage Bolt*	M6x16	4
8	JWBS14DP-208	Stand Support, Right		1
9	JWBS14DP-209	Hex Flange Nut*	M6	4
10	JWBS14DP-210	Stand Support, Left		1
11	PG-M02	JET Logo		1
12	TS-1550061	Flat Washer	M8	4
13	TS-2361081	Lock Washer	M8	4
14	TS-1540061	Hex Nut	M8	4
	JWBS14DP-HKCS	Stand Hardware Kit (not shown)		1

Note: * represents items included in JWBS14DP-HKCS Stand Hardware Kit

Electrical Schematic – 115V

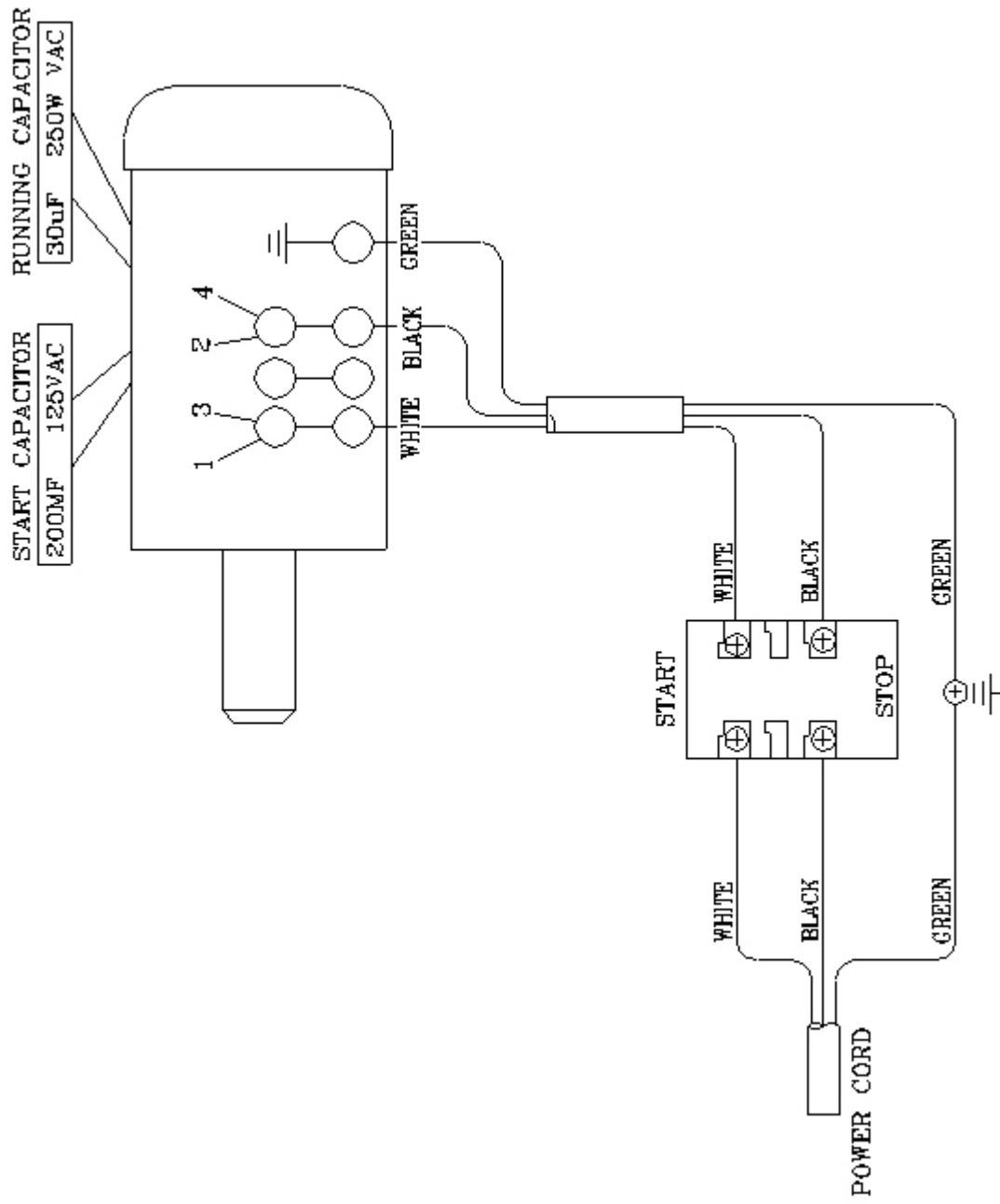

Electrical Schematic – 230V

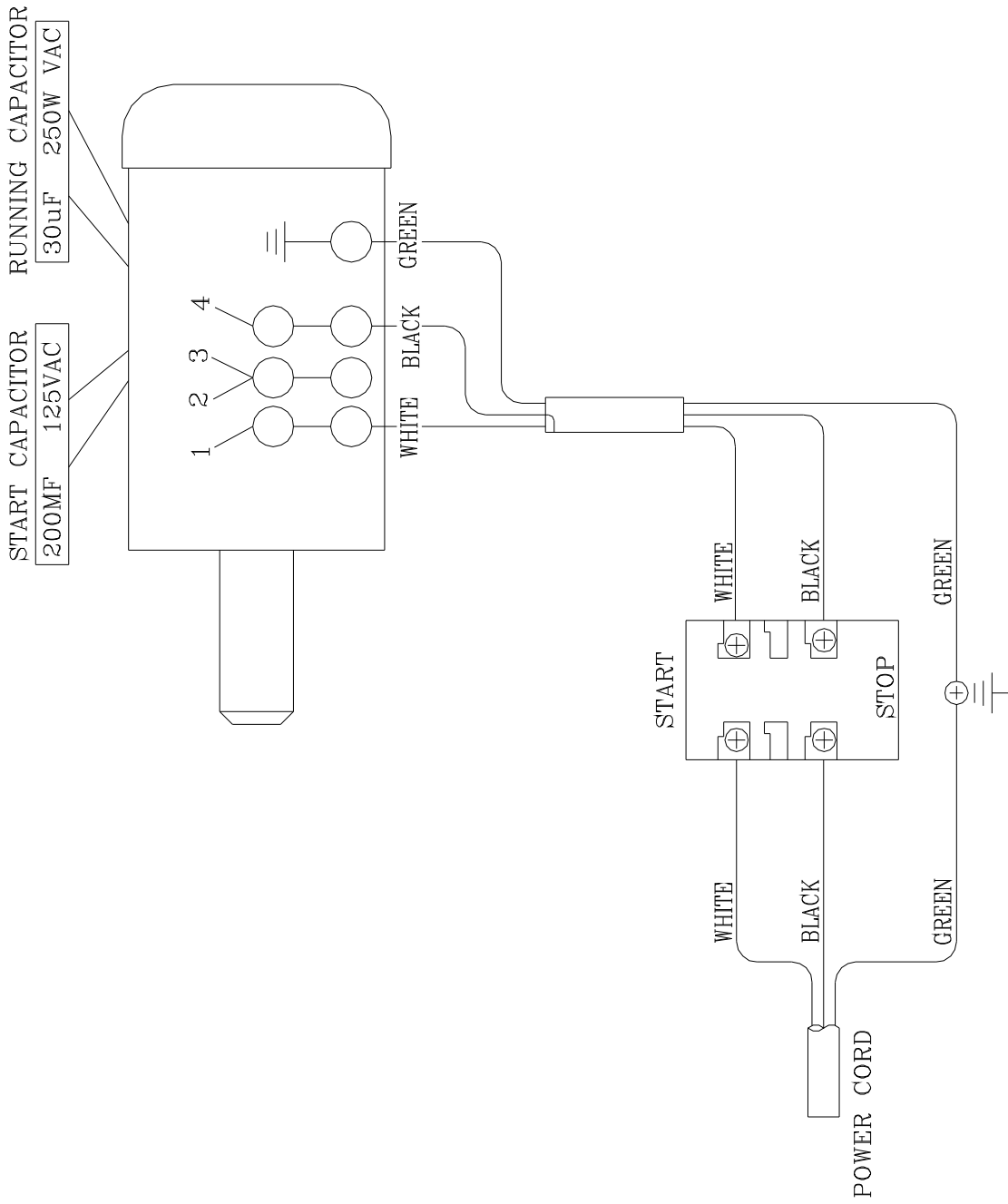



427 New Sanford Road
LaVergne, Tennessee 37086
Phone: 800-274-6848
www.jettools.com