

RBC PROPRIETARY AND CONFIDENTIAL INFORMATION
 This document is the property of REGAL BELOIT CORPORATION (RBC) including its subsidiaries and divisions and contains proprietary information of RBC. This document is loaned on the express condition that neither it nor the information contained therein shall be disclosed to others without the express written consent of RBC, and that the information shall be used by the recipient only as approved expressly by RBC. This document shall be returned to RBC upon its request. This document may be subject to certain restrictions under U.S. export control laws and regulations.

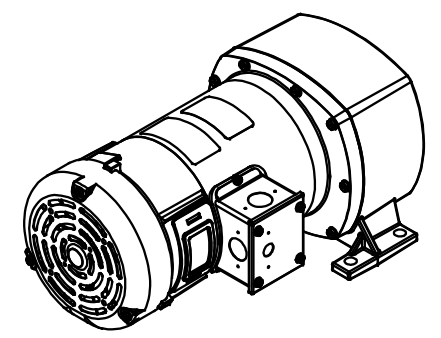
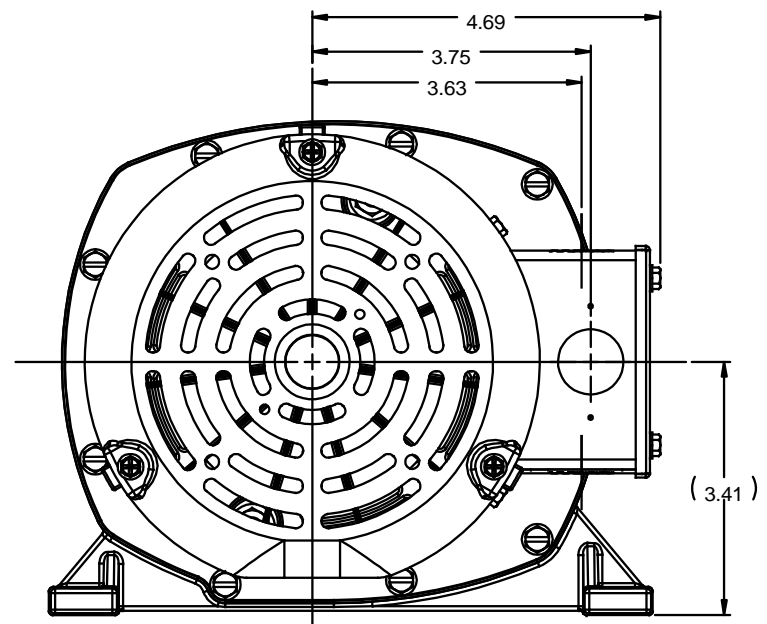
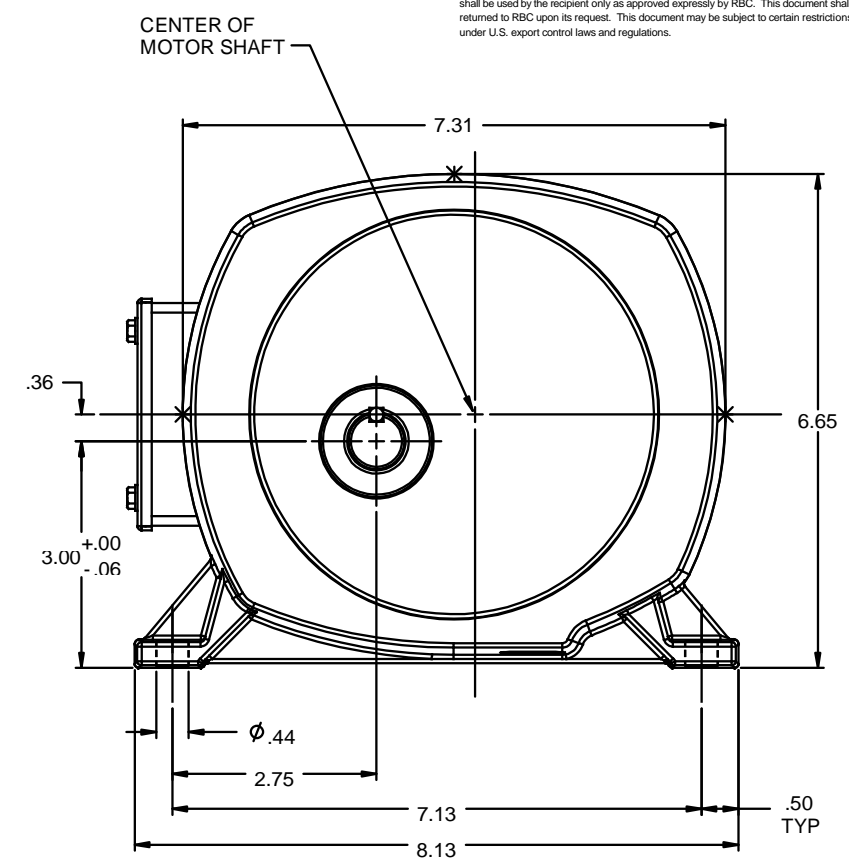
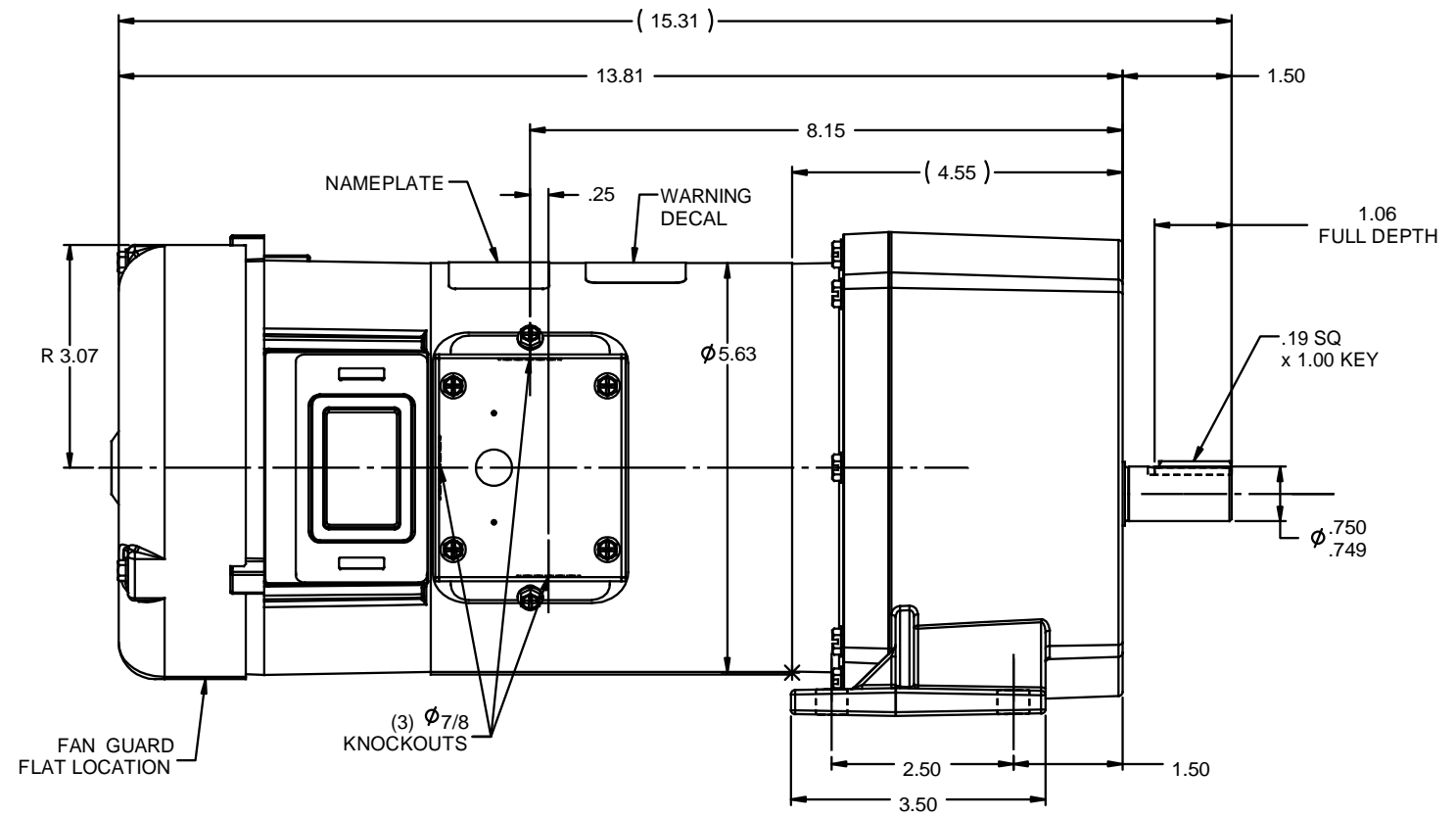

NOTES:
 1) GEARBOX OIL: MOBIL-MOBIL GEAR 600XP-320

108732.00	12	1/2	19:1	92	320
108731.00	12	1/2	42:1	42	705
CATALOG No.	VOLTS	INPUT HP	GEAR RATIO	RPM	F.L. TORQUE (LB-IN)

TOLERANCES UNLESS SPECIFIED		LEESON	ELECTRIC MOTORS GEARMOTORS AND DRIVES	DRAWN	IPG 6/30/10	
DEC	INCHES			CHK		
X	±.1	TITLE		APPR		
XX	±.03	OUTLINE		SCALE	1:2	
XXX	±.005	48 FRAME DC - P1100 GEARBOX		REF	032031	
XXXX	±.0005	MATL		EMF	108731.00	
NO	REVISION	BY & DATE	CHK	ANG	±1/2°	
THIRD ANGLE PROJECTION		RFP	PREV	SIZE	DRAWING NO	
		NETWORK FILE NAME	032038	B	032038	
					REV	00

RBC PROPRIETARY AND CONFIDENTIAL INFORMATION

This document is the property of REGAL BELOIT CORPORATION ("RBC") including its subsidiaries and divisions and contains proprietary information of RBC. This document is loaned on the express condition that neither it nor the information contained therein shall be disclosed to others without the express written consent of RBC, and that the information shall be used by the recipient only as approved expressly by RBC. This document shall be returned to RBC upon its request. This document may be subject to certain restrictions under U.S. export control laws and regulations.

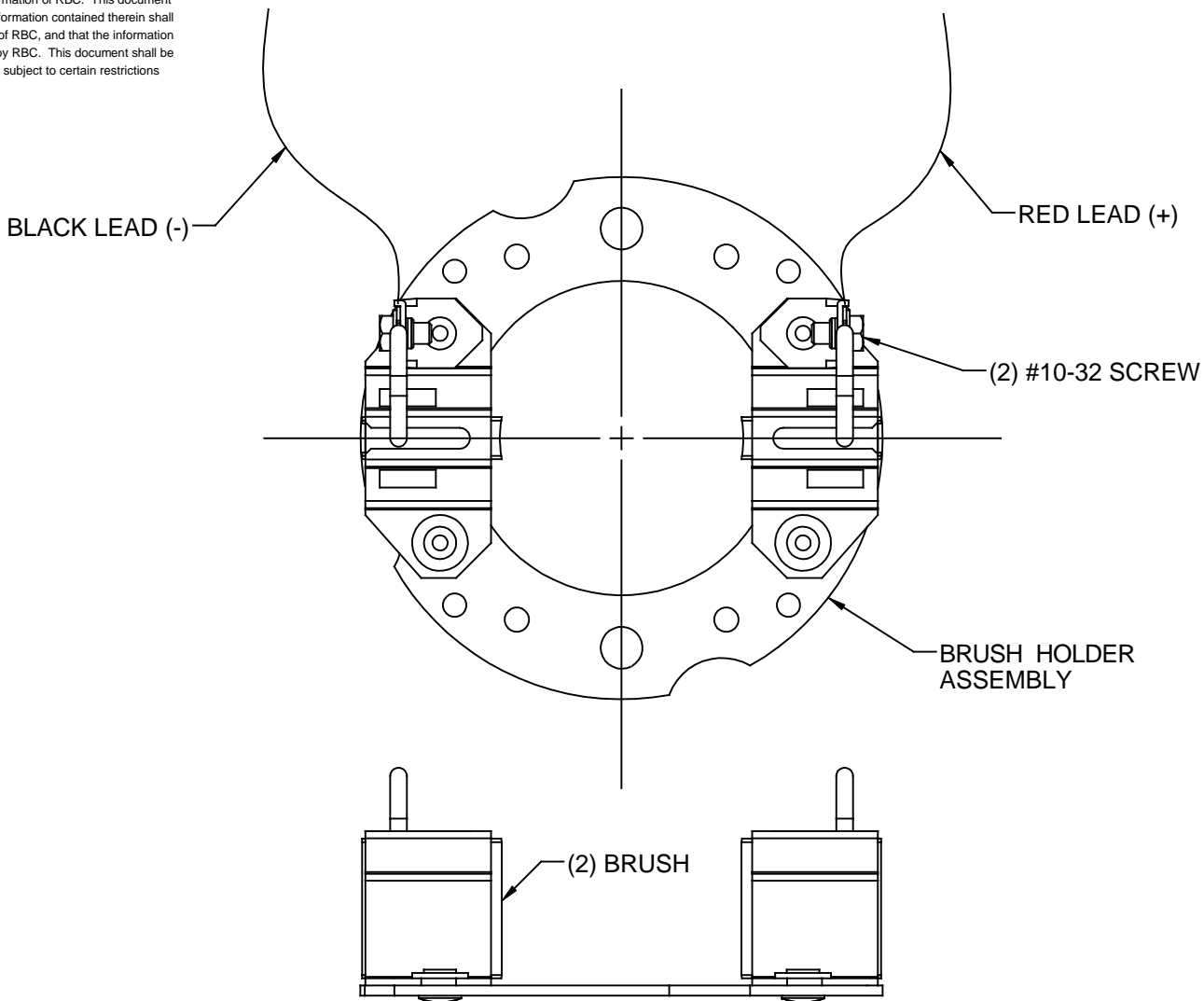

POLARITY: CCWLE

				TOLERANCES UNLESS SPECIFIED		 REGAL-BELOIT CORPORATION	DRAWN	IPG 12/10/07	
				DEC	INCHES		CHK	RWS 12/10/07	
				.X	±.1		APPR		
				.XX	±.01		SCALE	5:8	
01	INTERCHANGED RED AND BLACK LEADS	IPG 4/25/2008	BC	.XXX	±.005	TITLE	BRUSH/PLATE DRAWING		
	RELEASED	IPG 12/10/2007	RWS	.XXXX	±.0005		48 FRAME DC		
NO	REVISION	BY & DATE	CHK	ANG	±1/2°	MAT'L	REF	PR070348	
						FINISH	FMF	108022.75	
				RFP		PREV	PAGE	OF	
THIRD ANGLE PROJECTION				NETWORK FILE NAME		SIZE	DRAWING NO		
						A	499954.01		
							REV	01	