



A Regal Brand

Catalog # : M1125282.00

Product Type: ACSG

Description:

Model: M1125282.00

Stock: Y

Engineering Data

RPM	19	Volts		Volts	
HP/KW	.067	F.L. Amps		F.L. Amps	.4
Frame	31	S. F Amps		S. F Amps	
Max Amb	40	Hertz		Phase	3
Insul Class	F4	Duty	CONT	TYPE	TN
		Serv. Factor	1.0	PF	
Eff 100%		Eff 75%		Enclosure	TENV
Protection	NOT	Therm.Prot.		Bearing OPE	R6
Design		Code	H	Bearing PE	6000
UL	Yes	CSA	Yes	CE	No
Series	PZ	Nameplate	081188.01	Lubrication	
		Overrlung Ld.	155	Shaft Type	PARALLEL

Motor Wt.	10 LB	Mounting	SPECIAL	Rotation	RECONN
Carton Label	Subfrac Individual	Assembly	M1041178		
Winding	MT31419	Shaft Dia.	1/2	Ext. Diag2.	
GROUP :	1 A	Paint	M1305027.01	Packaging	M1307027.01
Test Card	01	Outline	M1031002	Cust Part No	

Form Factor		RMS Amps	
Torque		Peak	
AB Code		Peak@DegC	
Resistance			
Connection		Const Torque	

Rework Status                      Rework TYPE

4Explosion Proof		2Brake Motors
Temp Op Code		FORCE
Class	GROUP	VDC
Class	GROUP	ADC

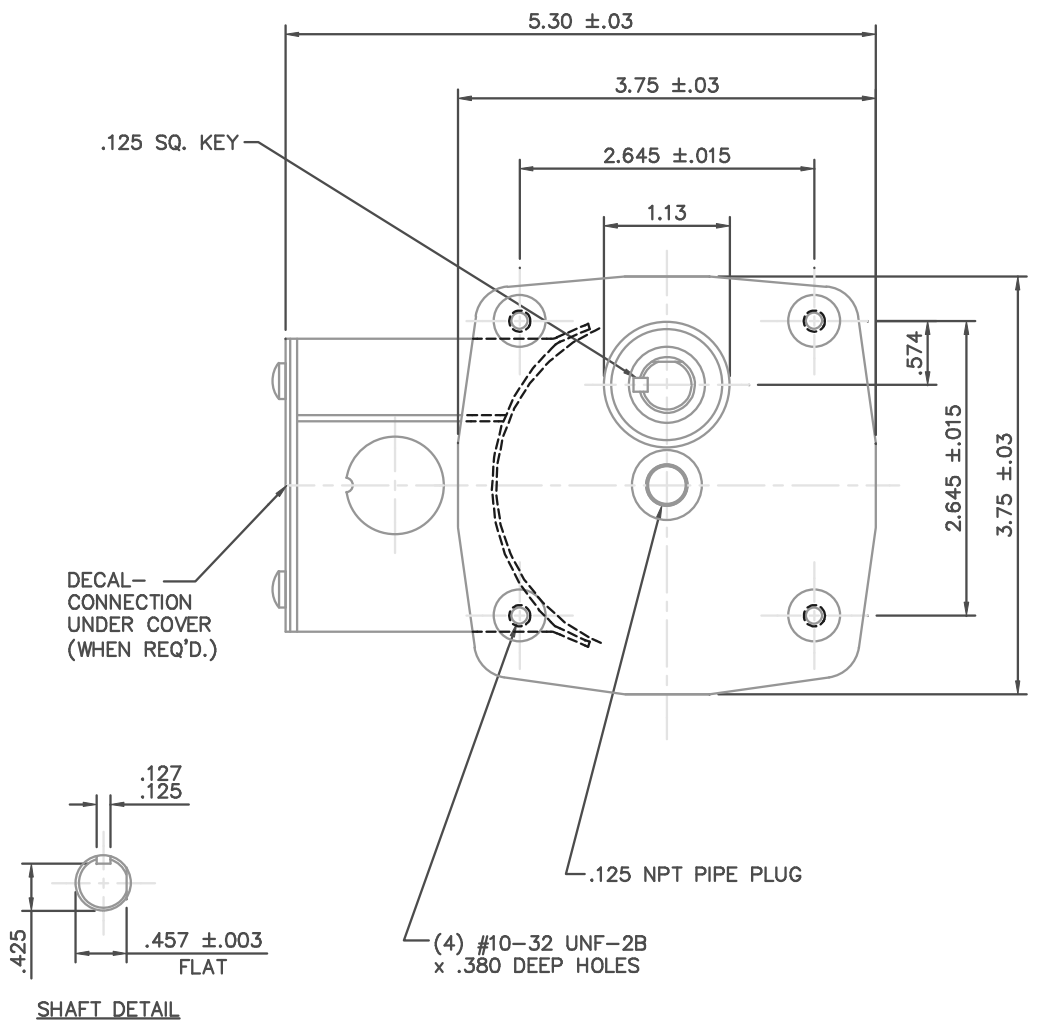
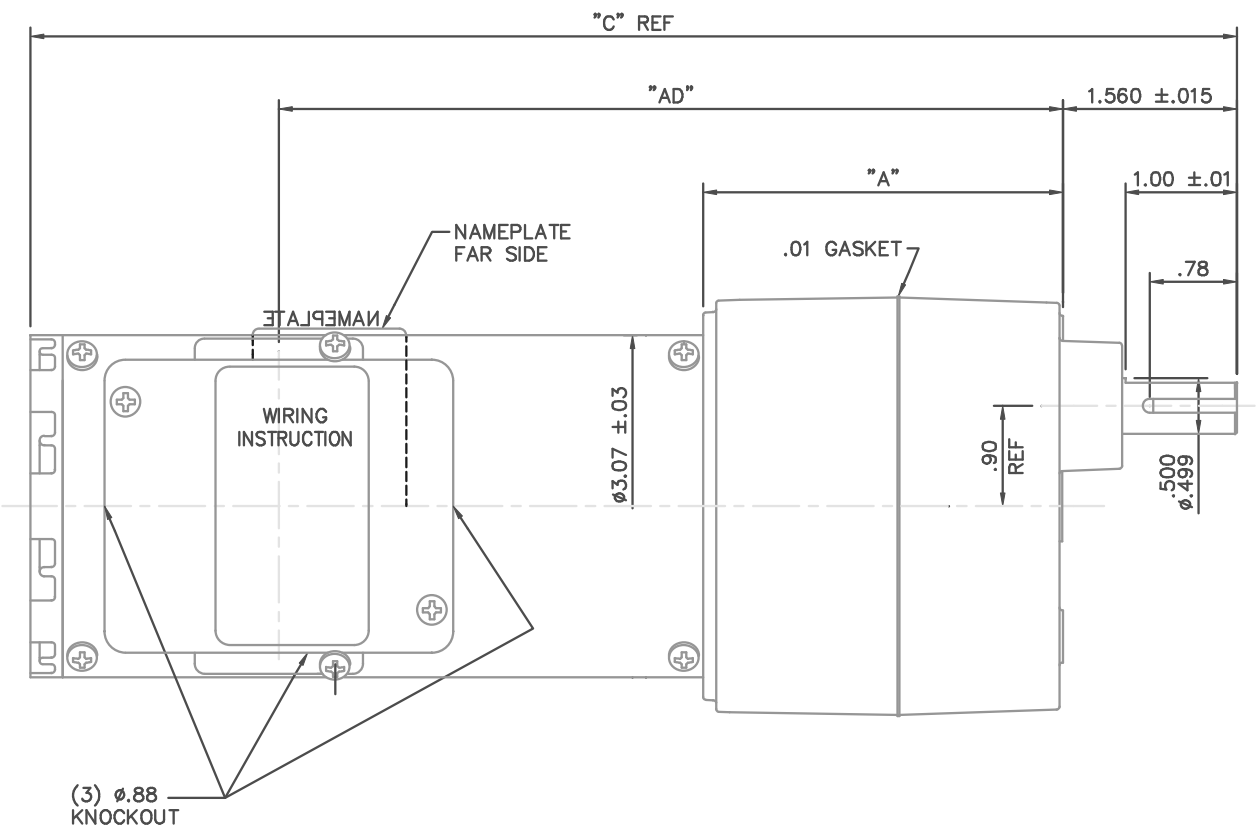

CATALOG NUMBER	OUTPUT RPM	FULL LOAD TORQUE LB.-IN.	INPUT HP	OVERHUNG LOAD LBS.	RATIO TO 1	"C"	"AD"	"A"
M1125282.00	19	100	1/15	155	90	10.83	7.00	3.23
M1125283.00	57	56	1/15	155	30	10.03	6.24	2.43
M1125284.00	142	24	1/15	155	12	9.73	5.94	2.13
M1125285.00	283	12	1/15	155	6	9.73	5.94	2.13

NOTES:  
 1- ALL GEARING IS STEEL IN COMPOSITION.  
 2- GEARING IS OF AGMA #8 QUALITY OR BETTER.

NO.		REVISION	BY & DATE	CHK	ANG	FINISH	PREV
03		ADD "A" TO TABLE PER ISAAC 08-3733	LST 8/15/08		.X ±.1		
02		MIRRORED CONDUIT BOX MOUNTING SCREWS TO SHOW CORRECT ORIENTATION OF BOX; ECR 85528	KLS 12/19/05	RDW	.XX ±.03		
01		ADDED PERFORMANCE ATTRIBUTES TABLE	RLW 7/7/05		.XXX ±.005		
THIS DRAWING IN DESIGN AND DETAIL IS OUR PROPERTY AND MUST NOT BE USED EXCEPT IN CONNECTION WITH OUR WORK ALL RIGHTS OF DESIGN AND INVENTION ARE RESERVED THIS IS AN ELECTRONICALLY GENERATED DOCUMENT - DO NOT SCALE THIS PRINT				RFP	ANG ±1/2"	FINISH	
				DIST		CAD FILE M1031002	
						SIZE B	DRAWING NO. M1031002
							REV. 03

**LEESON** ELECTRIC MOTORS GEARMOTORS AND DRIVES  
 DRAWN LST 6/15/05  
 CHK RW 6/22/05  
 APPD KH 6/22/05  
 TITLE OUTLINE- 31 FRAME AC TENV- PZ GEARBOX  
 SCALE 3=4  
 REF PR040177  
 FMF  
 PREV

# Uncontrolled Copy

005102-01

VIEW FROM OUTSIDE OF MOTOR AT SWITCH END.

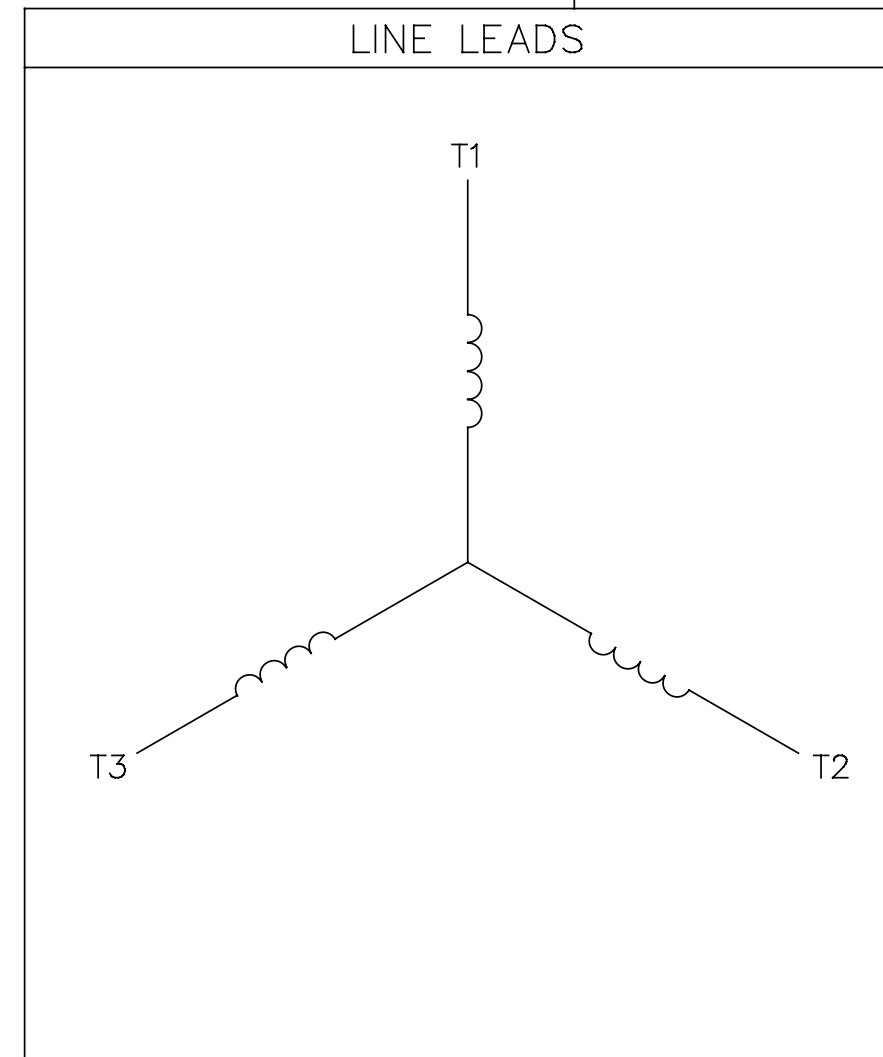
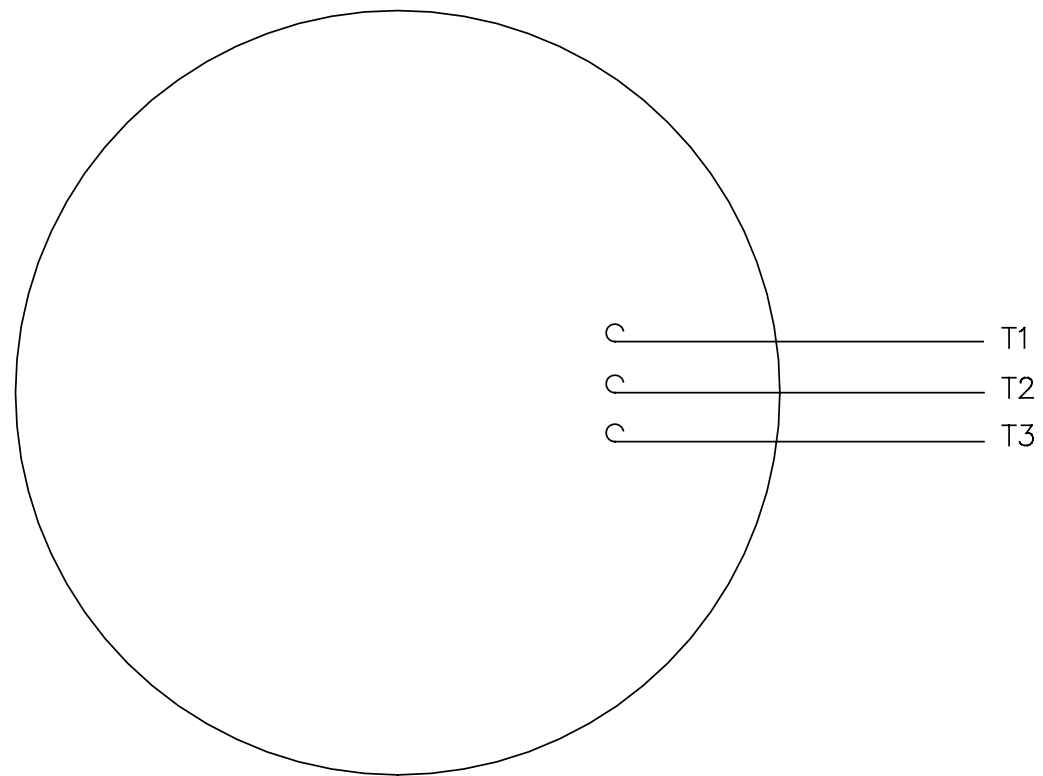

CONNECT LEADS AS FOLLOWS  
FOR FOUR CONDUCTOR CORD ( )

CORD	L1 (RED)	L2 (WHITE)	L3 (BLACK)	(GREEN)
MOTOR	T1	T2	T3	GROUND

				TOLERANCES UNLESS SPECIFIED		<b>REGAL</b> ™ <b>Regal Beloit America, Inc.</b>		DRAWN JRW 9/11/75	
				DEC.	INCHES			CHK	
				.X	±.1			APPD JCW 9/11/75	
08	UPDATED TO REGAL LOGO	SAJ 06/26/15	AJY	.XX	±.01	TITLE EXTERNAL WIRING DIAGRAM TYPE "T" W/O PROTECTOR		SCALE 1=1	
07	UPDATED TO CURRENT STANDARDS	DBT 5/30/97		.XXX	±.005			REF W-T6343-6	
06	REDRAWN ON CAD; ADDED DECAL NUMBER	SAW 1/24/95		.XXXX	±.0005	MAT'L. DECAL - 004169		FMF 6T17FB7	
NO.	REVISION	BY & DATE	CHK	ANG	±1/2"	FINISH		PREV	
THIS DRAWING IN DESIGN AND DETAIL IS OUR PROPERTY AND MUST NOT BE USED EXCEPT IN CONNECTION WITH OUR WORK ALL RIGHTS OF DESIGN AND INVENTION ARE RESERVED THIS IS AN ELECTRONICALLY GENERATED DOCUMENT - DO NOT SCALE THIS PRINT			RFP	5/1/02	CAD FILE	00510201	SIZE	DRAWING NO.	REV.
			DIST	BRF-NLV			A	005102-01	08