



A Regal Brand

Catalog # : M1145023.00

Product Type: ACSG

Description:

Model: M1145023.00

Stock: Y

Engineering Data

RPM	15/13	Volts	115/230	Volts	
HP/KW	.06/.06	F.L. Amps	1.5/.75	F.L. Amps	1/5
Frame	38	S. F Amps		S. F Amps	
Max Amb	40	Hertz		Phase	1
Insul Class	F4	Duty	CONT	TYPE	PN
		Serv. Factor	1.0/1.0	PF	
Eff 100%		Eff 75%		Enclosure	TENV
Protection	NOT	Therm.Prot.		Bearing OPE	6201-13
Design		Code	D	Bearing PE	6201-13
UL	Yes	CSA	Yes	CE	Yes
Series	P240	Nameplate	M1004149.02	Lubrication	
		Overrlung Ld.	407	Shaft Type	PARALLEL

Motor Wt.	16 LB	Mounting	SPECIAL	Rotation	RECONN
Carton Label	Subfrac Individual	Assembly	M1040400		
Winding	MP38420	Shaft Dia.	5/8	Ext. Diag2.	
GROUP :	3 A	Paint	M1305027.01	Packaging	M1307027.01
Test Card	02	Outline	M1030380	Cust Part No	

Form Factor			RMS Amps	
Torque		RMS Amps		
AB Code		Peak		
Resistance		Peak@DegC		
Connection			Const Torque	

Rework Status Rework TYPE

4Explosion Proof			2Brake Motors
Temp Op Code			FORCE
Class	GROUP		VDC
Class	GROUP		ADC

M1030380

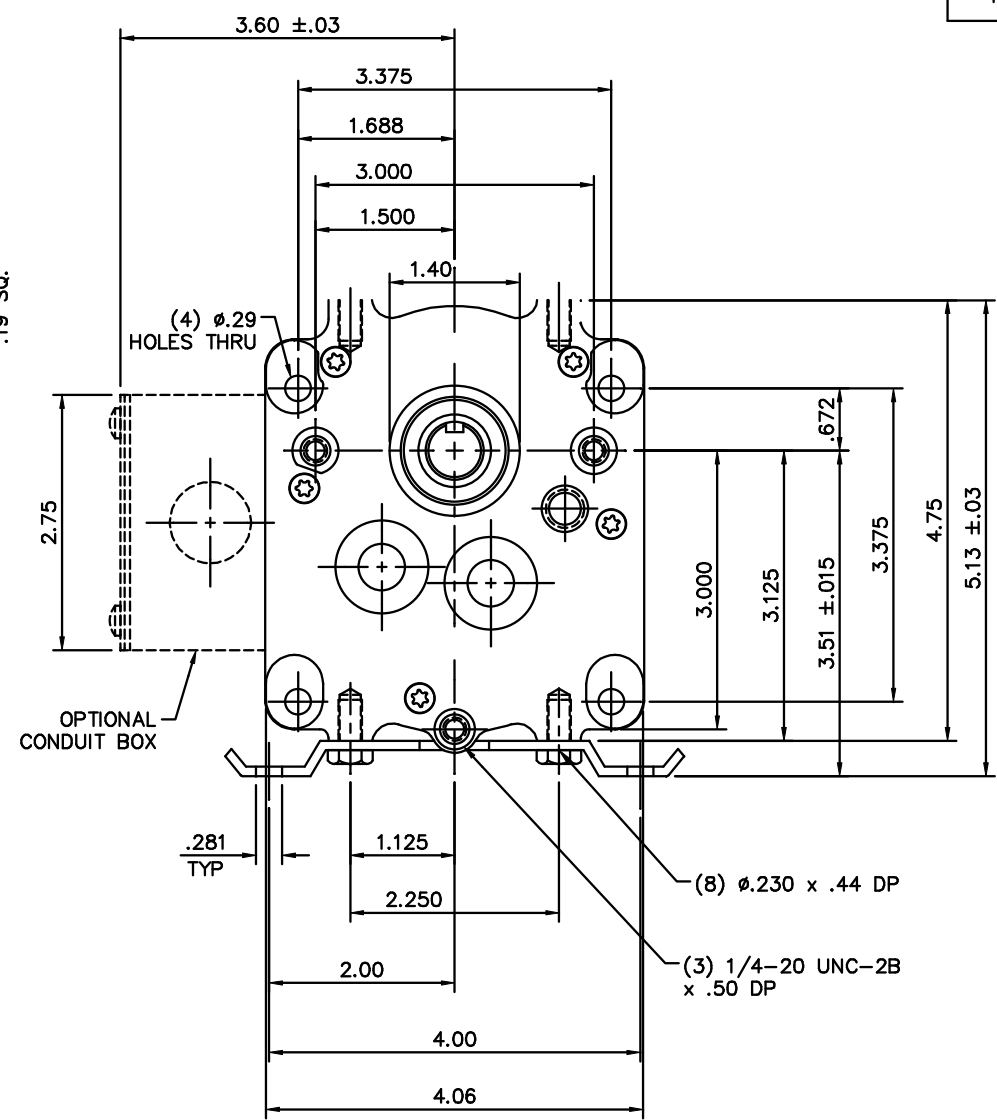
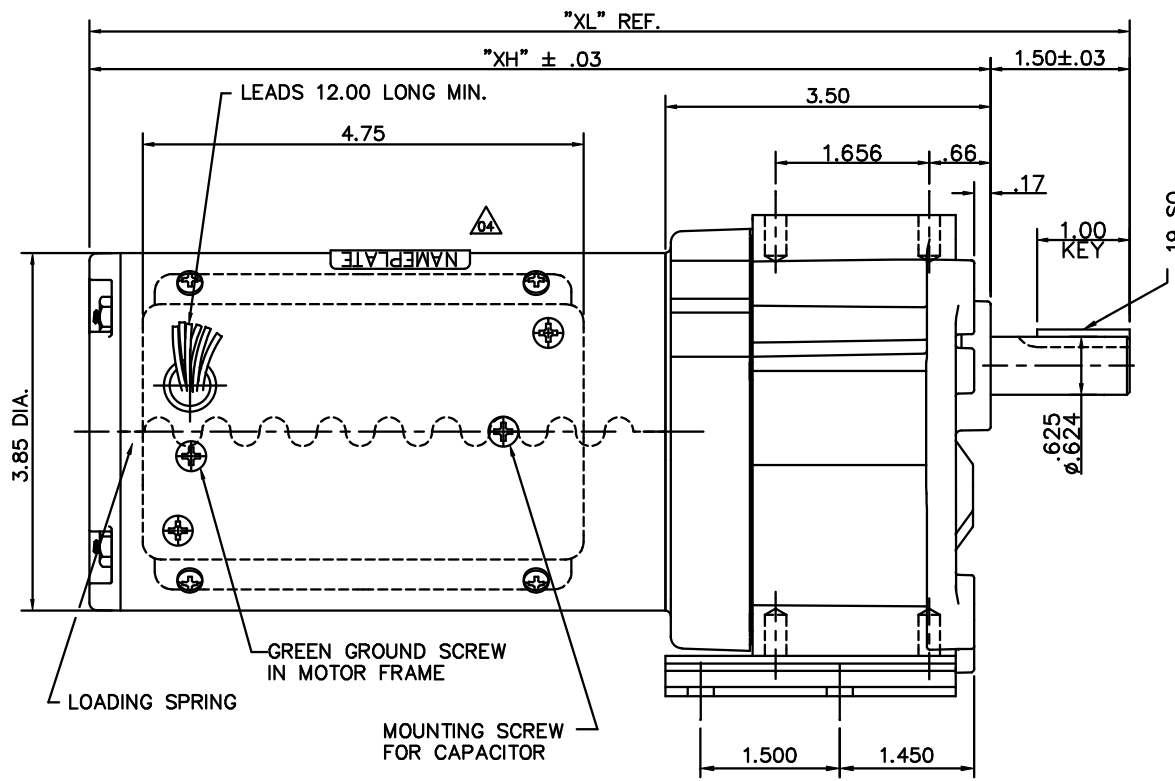

CATALOG NUMBER	OUTPUT RPM	FULL LOAD TORQUE LB.-IN.	INPUT HP	OVERHUNG LOAD LBS.	GEARMOTOR TYPE & FRAME	RATIO TO 1	"XL"	"XH"
M1145023.00	15	208	1/15	407	P243-38	114	10.46	8.96
M1145024.00	30	135	1/15	330	P242-38	52	10.46	8.96
M1145025.00	45	92	1/15	292	P242-38	35	10.46	8.96
M1145026.00	70	61	1/15	256	P242-38	23	10.46	8.96
M1145027.00	97	43	1/15	232	P242-38	16.5	10.46	8.96
M1145028.00	139	30	1/15	208	P242-38	11.5	10.46	8.96
M1145029.00	8	345	1/15	491	P243-38	216	10.46	8.96

05	EXTENDED 3 PT MOUNTING HOLES .14" TO MAKE FLUSH	RLW	6/25/02		TOLERANCES UNLESS SPECIFIED	ELECTRIC MOTORS GEARMOTORS AND DRIVES	DRAWN	SPV 05/21/94
04	REV'D NAMEPLATE APPEARANCE FOR ASSEMBLY	BJB	6/25/02	DWF	DEC. INCHES		CHK	
	CLARITY PER ECR 65231				.X ±.1	APPD	DWF 05/21/94	
03	3.50 WAS 3.562, 5.13 WAS 5.19	SPV	06/29/95		.XX ±.03	TITLE	SCALE 5=8	
02	ADDED CAPACITOR MOUNTING SCREW	SPV	06/29/95		.XXX ±.005	OUTLINE DRAWING	REF	
01	REVISED TO NEW STOCK STANDARDS	TMZ	05/15/95		.XXXX ±.0005	P240 GEARMOTOR - 38 FRAME A.C.	FMF M1145023	
	REVISION	BY & DATE		CHK	ANG ±1/2'	MAT'L	PREV	
THIS DRAWING IN DESIGN AND DETAIL IS OUR PROPERTY AND MUST NOT BE USED EXCEPT IN CONNECTION WITH OUR WORK ALL RIGHTS OF DESIGN AND INVENTION ARE RESERVED THIS IS AN ELECTRONICALLY GENERATED DOCUMENT - DO NOT SCALE THIS PRINT						RFP	CAD FILE	M1030380
						DIST	SIZE	DRAWING NO.
							B	M1030380
								REV. 05

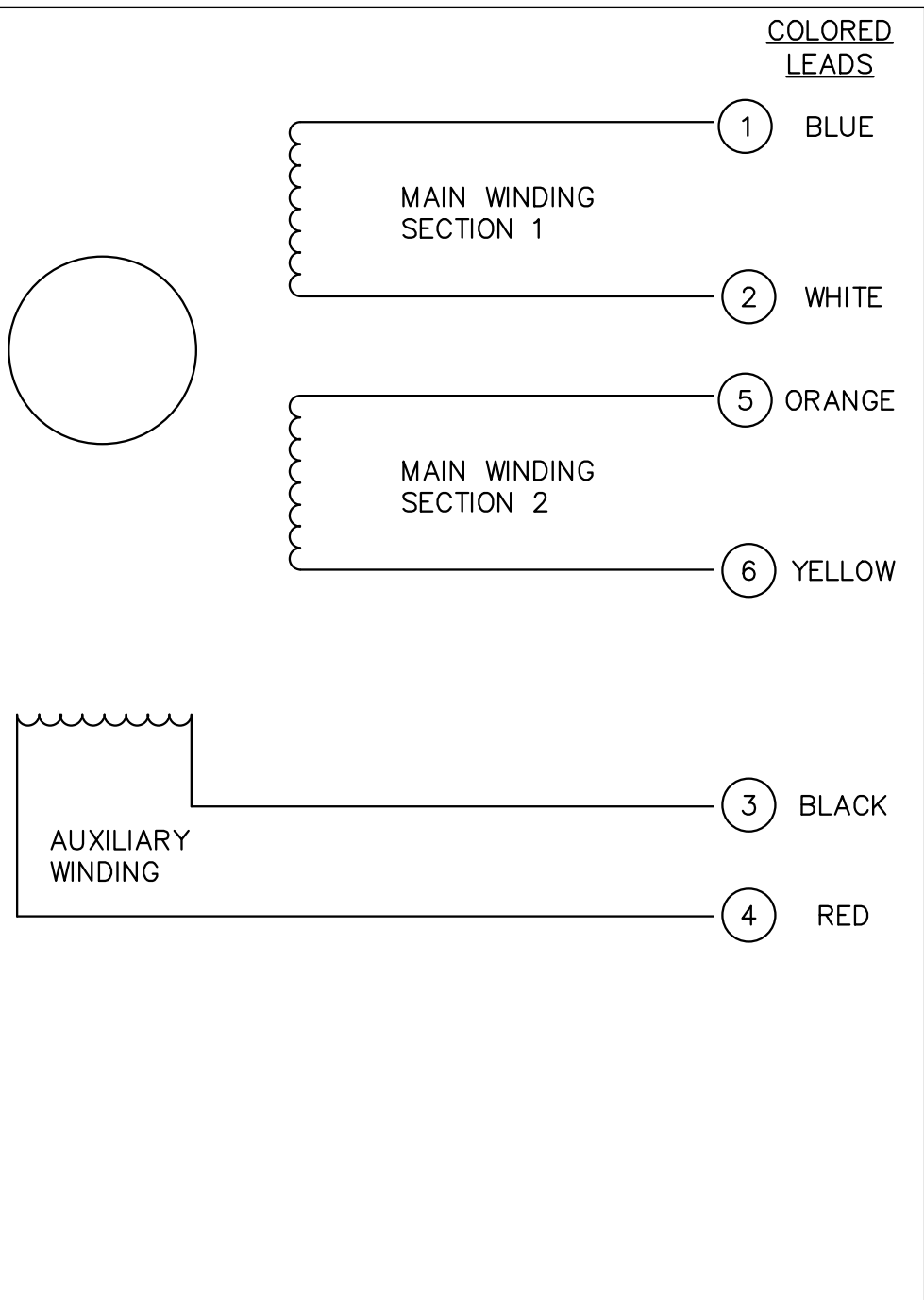

M1005040.02

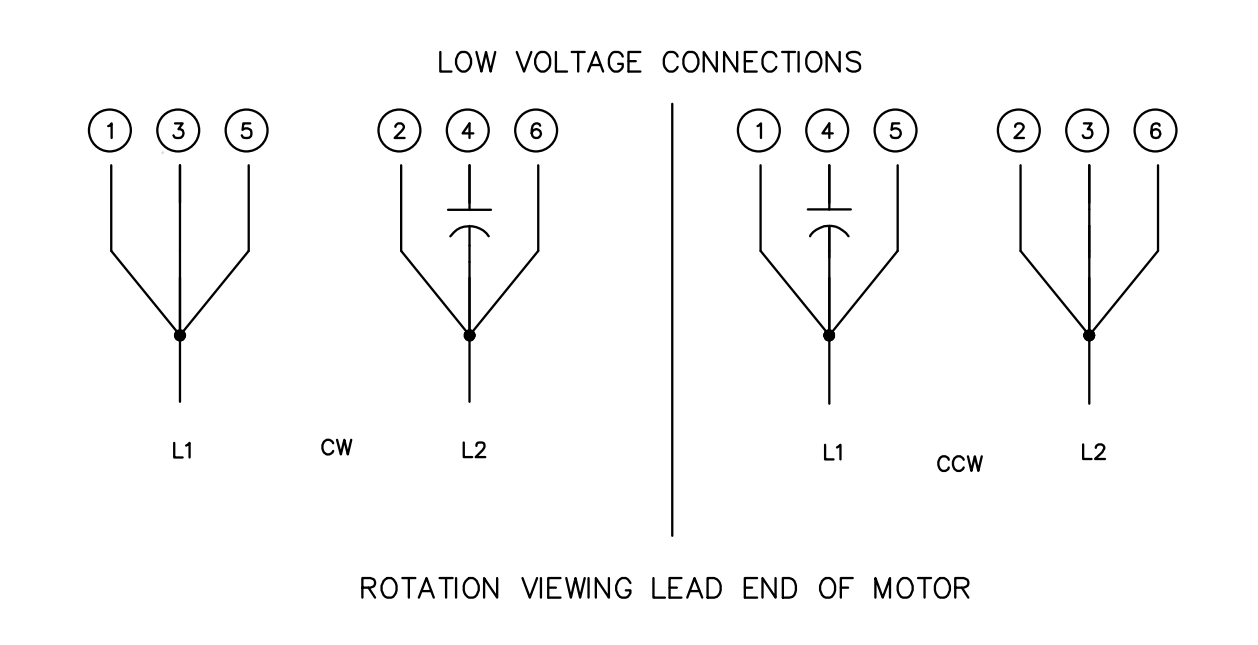
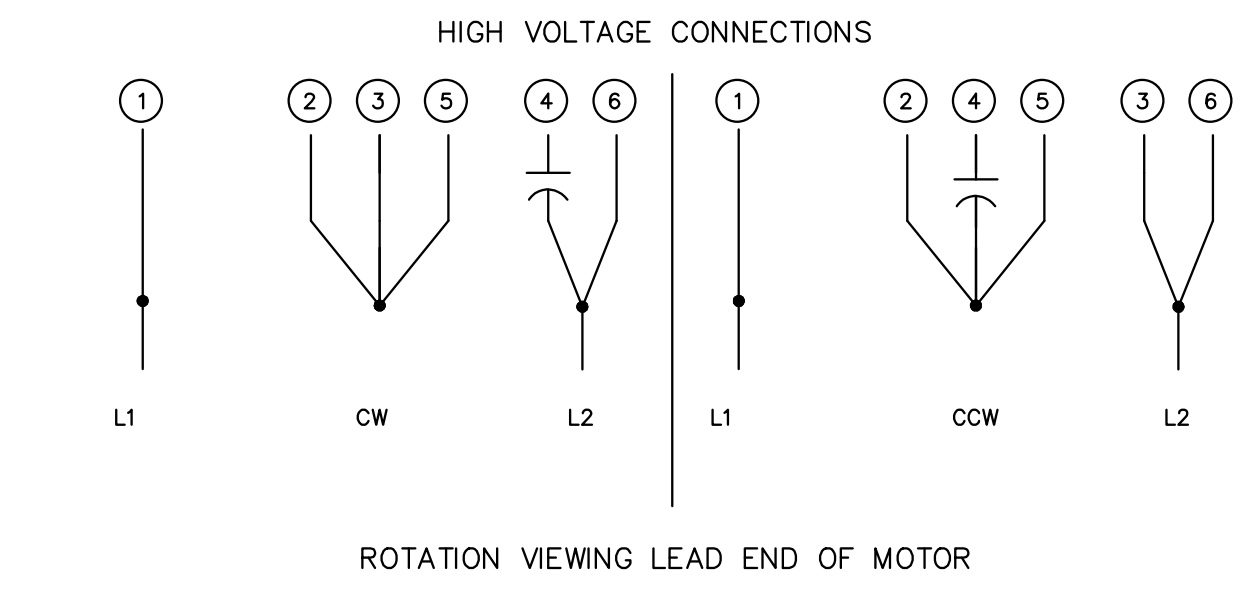

				TOLERANCES UNLESS OTHERWISE SPECIFIED		LEESON ELECTRIC CORPORATION		TITLE EXTERNAL WIRING DIAGRAM DUAL VOLTAGE DUAL ROTATION	
				DECIMALS					
				.00	± .01	DRAWN	DK	MAT'L.	
02	REDRAWN ON CAD	AJR	6/28/99	.000	± .005	CH'K'D.	10/3/91		
01	REMOVED CAP FROM LEFT DIAGRAM	DD	9/16/95	.0000	± .0005	APPR.	10/3/91	DRAWING NO. M1005040.02	
NO.	REVISION	BY	DATE	FRACTIONS	± 1/64	SCALE	NONE		
THIS DRAWING IN DESIGN AND DETAIL IS OUR PROPERTY AND MUST NOT BE USED EXCEPT IN CONNECTION WITH OUR WORK ALL RIGHTS OF DESIGN AND INVENTION ARE RESERVED				ANGLES	± 1/2°	REF.		FINISH	SIZE A
				INCH/MM		FMF	PR91376	LECO CORP.	