



A Regal Brand

Catalog # : M1145030.00

Product Type: ACSG

Description:

Model: M1145030.00

Stock: Y

Engineering Data

RPM	16/13	Volts	115/230	Volts	
HP/KW	.16/.16	F.L. Amps	3/1.5	F.L. Amps	2.1/1.05
Frame	38	S. F Amps		S. F Amps	
Max Amb	40	Hertz		Phase	1
Insul Class	F4	Duty	CONT	TYPE	PF
		Serv. Factor	1.0/1.0	PF	
Eff 100%		Eff 75%		Enclosure	TEFC
Protection	NOT	Therm.Prot.		Bearing OPE	6201-13
Design		Code	D	Bearing PE	6201-13
UL	Yes	CSA	Yes	CE	Yes
Series	P240	Nameplate	M1004149.02	Lubrication	
		Overrlung Ld.	399	Shaft Type	PARALLEL

Motor Wt.	18 LB	Mounting	SPECIAL	Rotation	RECONN
Carton Label	Subfrac Individual	Assembly	M1040419		
Winding	MP38419	Shaft Dia.	5/8	Ext. Diag2.	
GROUP :	3 B	Paint	M1305027.01	Packaging	M1307027.01
Test Card	03	Outline	M1030381	Cust Part No	

Form Factor		RMS Amps	
Torque		Peak	
AB Code		Peak@DegC	
Resistance			
Connection		Const Torque	

Rework Status                      Rework TYPE

4Explosion Proof		2Brake Motors
Temp Op Code		FORCE
Class	GROUP	VDC
Class	GROUP	ADC

M1030381

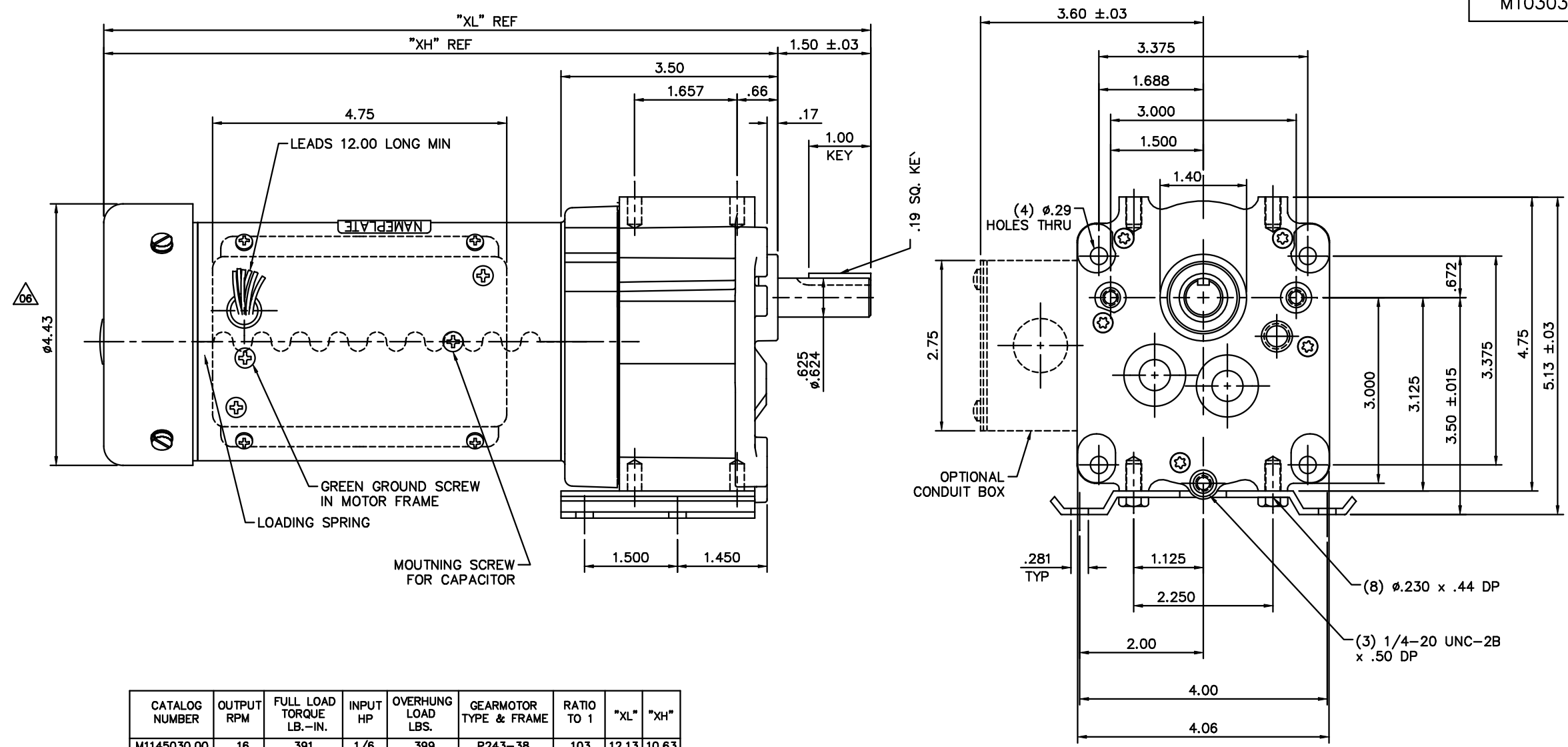

CATALOG NUMBER	OUTPUT RPM	FULL LOAD TORQUE LB.-IN.	INPUT HP	OVERHUNG LOAD LBS.	GEARMOTOR TYPE & FRAME	RATIO TO 1	"XL"	"XH"
M1145030.00	16	391	1/6	399	P243-38	103	12.13	10.63
M1145031.00	30	295	1/6	330	P243-38	58	12.13	10.63
M1145032.00	40	219	1/6	303	P243-38	43	12.13	10.63
M1145033.00	60	157	1/6	268	P242-38	29	12.13	10.63
M1145034.00	90	103	1/6	237	P242-38	19	12.13	10.63
M1145035.00	156	60	1/6	201	P242-38	10.6	12.13	10.63

NO.	REVISION	BY & DATE	CHK	ANG	FINISH	REV.
07	EXTENDED 3 PT MOUNTING HOLES .14" TO MAKE FLUSH	RLW 6/25/02				
06	ADDED FANGUARD DIM	BPW 12/19/01				
05	REV'D NAMEPLATE APPEARANCE FOR ASSEMBLY	BJB 12/11/01	DWF	.X	±.1	
04	CLARITY PER ECR 65231			.XX	±.03	
04	3.50 WAS 3.562, 5.13 WAS 5.19	SPV 04/28/97		.XXX	±.005	
03	ADDED FLAT TO FAN SHROUD	DWF 09/23/96		.XXXX	±.0005	
TOLERANCES UNLESS SPECIFIED DEC. INCHES TITLE: P240 GEARMOTOR - 38 FRAME A.C. MAT'L:						DRAWN: DWF 10/03/94 CHK: APPD: SPV 10/03/94 SCALE: 5-8 REF: FMF: M1145030 PREV:
THIS DRAWING IN DESIGN AND DETAIL IS OUR PROPERTY AND MUST NOT BE USED EXCEPT IN CONNECTION WITH OUR WORK ALL RIGHTS OF DESIGN AND INVENTION ARE RESERVED THIS IS AN ELECTRONICALLY GENERATED DOCUMENT - DO NOT SCALE THIS PRINT						RFP: CAD FILE M1030381 SIZE: B DRAWING NO.: M1030381 REV.: 07

M1005040.02

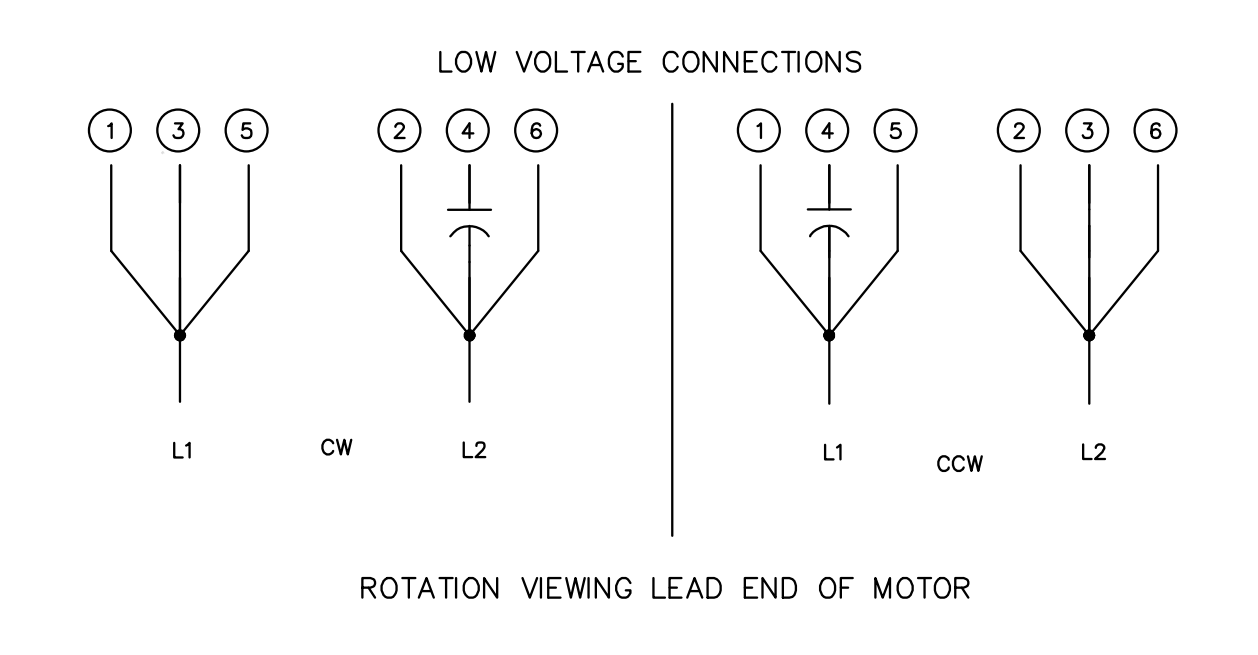
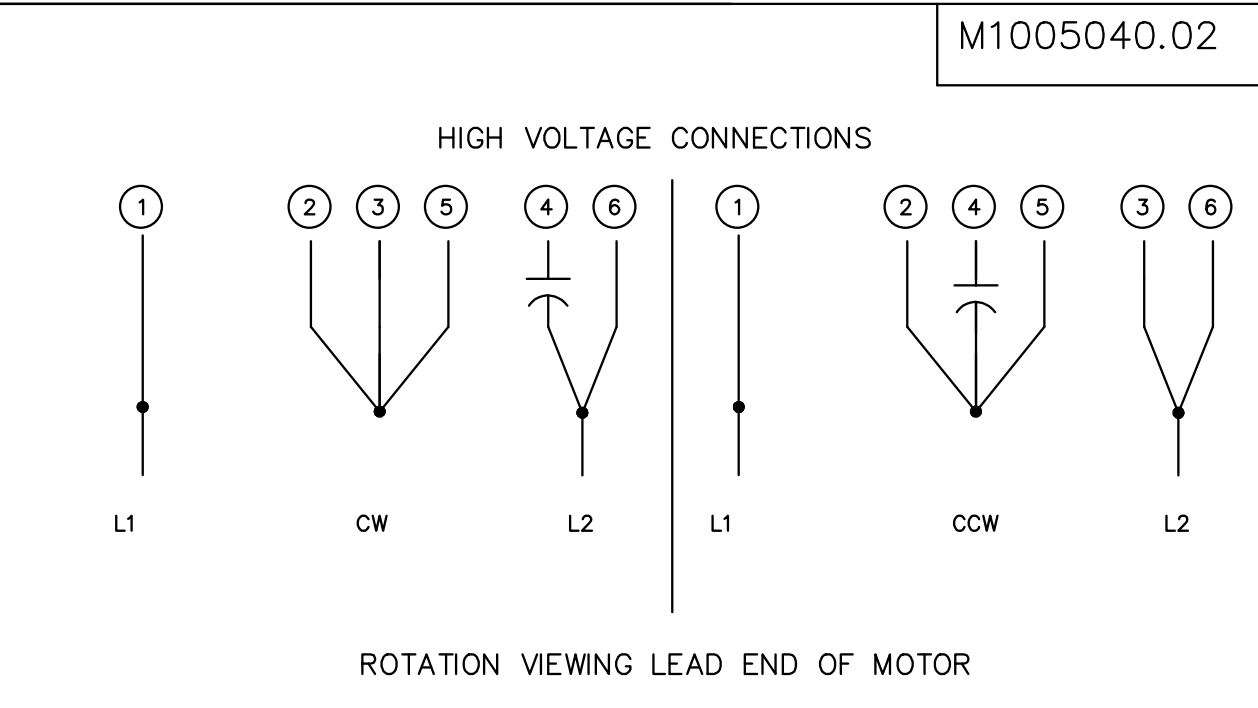
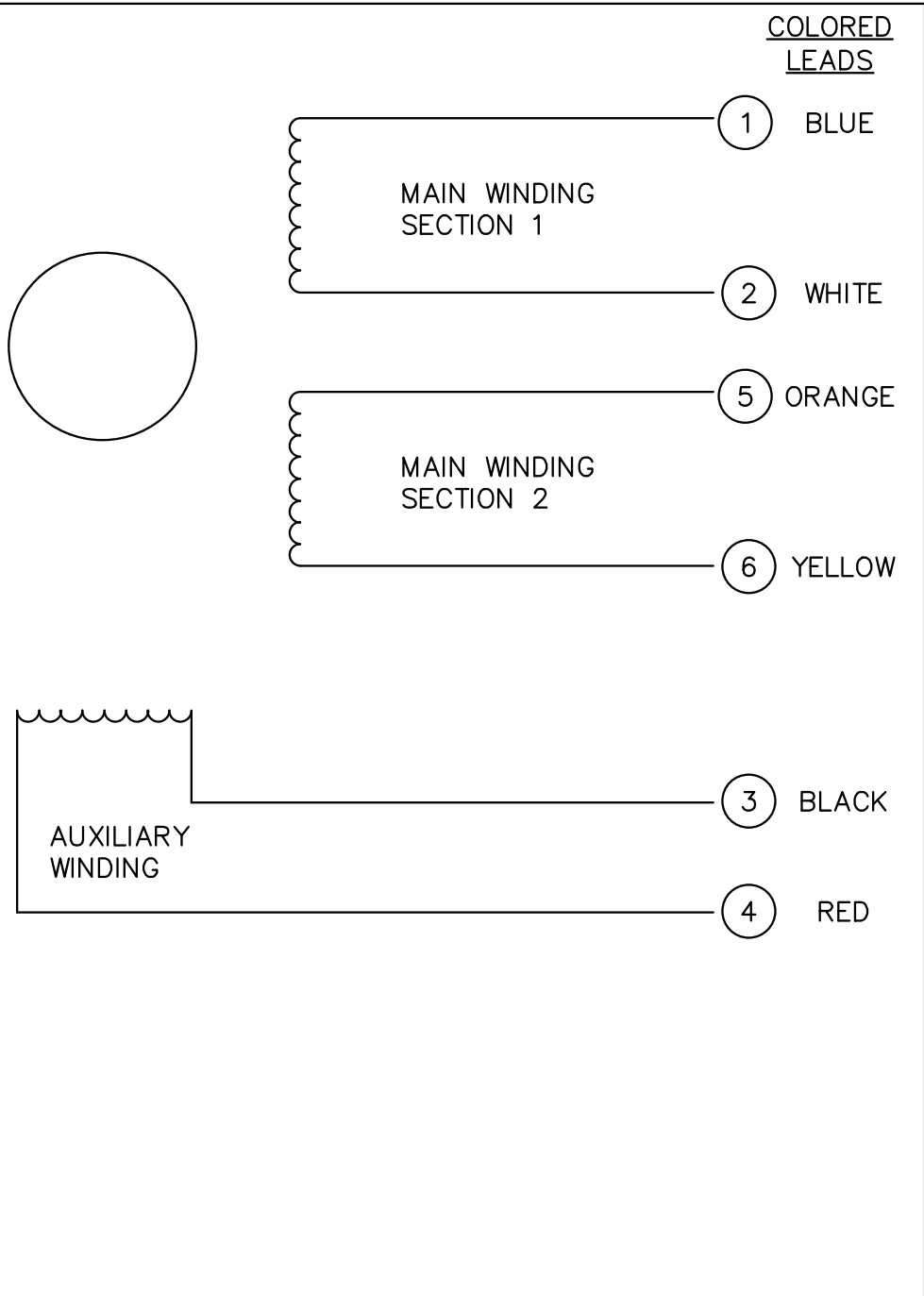

				TOLERANCES UNLESS OTHERWISE SPECIFIED		<b>LEESON</b> ELECTRIC CORPORATION		TITLE EXTERNAL WIRING DIAGRAM DUAL VOLTAGE DUAL ROTATION	
				DECIMALS					
				.00	± .01	DRAWN	DK	MAT'L.	
02	REDRAWN ON CAD	AJR	6/28/99	.000	± .005	CH'K'D.	10/3/91		
01	REMOVED CAP FROM LEFT DIAGRAM	DD	9/16/95	.0000	± .0005	APPR.	10/3/91	DRAWING NO. M1005040.02	
NO.	REVISION	BY	DATE	FRACTIONS	± 1/64	SCALE	NONE		
THIS DRAWING IN DESIGN AND DETAIL IS OUR PROPERTY AND MUST NOT BE USED EXCEPT IN CONNECTION WITH OUR WORK ALL RIGHTS OF DESIGN AND INVENTION ARE RESERVED				ANGLES	± 1/2°	REF.		FINISH	SIZE A
				INCH/MM		FMF	PR91376	LECO CORP.	