

ELKAY®

SPECIFICATIONS

No Lead Single SwirlFlo® Wall Mount, Barrier-Free Drinking Fountain with EZH2O® Bottle Filling Station Model EZWS-EDFPBM114K

Rated for Indoor Use Only

PRODUCT SPECIFICATION

Architectural fountain with integral bottle filling station. EZWS-EDFPBM114K shall deliver non-chilled drinking water unless connected to a remote water chiller. Unit shall be stainless steel construction with plastic ABS alcove. Sensor-activation with an auto 20-second shut-off timer. Shall include Green Ticker™ displaying count of plastic bottles saved from waste. Bottle filler shall provide 1.5 gpm flow rate with laminar flow to minimize splashing and 1.1 gpm flow rate when connected to a remote water chiller. Shall include integrated silver ion anti-microbial protection in key areas. Unit shall meet ADA guidelines. Unit shall be lead-free design which is certified to NSF/ANSI 61 and 372 and meets Federal and State low-lead requirements. Unit shall be certified to UL399 and CAN/CSA 22.2 No. 120.

FOUNTAINS GENERAL

Fully exposed single fountain basin made of 300 series stainless steel, polished to a lustrous satin finish with high shine outer edge.

Fountain has contoured basin that minimizes splashing. Flexi-Guard® Safety bubbler is keyed in location to prevent rotation. Fully functional, vandal-resistant front push button on the fountain. Flow regulator provides constant stream from 20 to 105 psi water pressure.

BOTTLE FILLER FEATURES

- No-touch, sensor-activated bottle filler
- Auto 20-second shut-off
- Integrated Silver Ion Anti-Microbial Protection in key areas
- Quick Fill Rate: 1.5 gpm
- Laminar Flow provides minimal splash
- Real Drain System eliminates standing water
- Visual User Interface display includes:
 - Innovative Green Ticker™ counts bottles saved from waste

Warranty: Electrical components and water system are warranted for 12 months from date of installation or 18 months from factory shipment, whichever date falls first.



Model
EZWS-EDFPBM114K

CONSTRUCTION

EZWS-EDFPBM114K single fountain furnished complete with Flexi-Guard® Safety bubbler. Fully assembled with front push button on the fountain, flow regulator (20 to 105 psi), stainless steel back panel. No traps are furnished.

- Stainless Steel bottle filler construction with ABS plastic alcove
- Furnished with wall mounting frame constructed of galvanized steel
- Mounting can be ordered separately for pre-install

CERTIFICATIONS / STANDARDS

- ADA Compliant
- UL399 and CAN/CSA 22.2 No. 120 Certified
- ANSI/NSF 61 and 372 Certified
- GreenSpec® Listed



This specification describes an Elkay product with design, quality and functional benefits to the user. When making a comparison of other producer's offerings, be certain these features are not overlooked.

No Lead Single SwirlFlo®
Wall Mount, Barrier-Free
Drinking Fountain with EZH2O® Bottle Filling Station
Model EZWS-EDFPBM114K

ELKAY®
ROUGH-IN DIMENSIONS

INSTALLER NOTE:

THIS DRINKING FOUNTAIN IS FURNISHED WITH A BUBBLER AND VALVE INCLUDING ALL CONNECTING FITTINGS WHICH ARE MANUFACTURED OF COMPLETELY LEAD FREE MATERIAL. SHUTOFF VALVE (NOT FURNISHED) TO ACCEPT 3/8" O.D. UNPLATED COPPER TUBE.

WALL OPENING

IMPORTANT: It is necessary to create a wall opening 18 3/4" W x 31 3/4" H and 25" above the floor line.

ELECTRICAL DATA

Electrical outlet, three (3) conductor grounded. Locate within safe reach of power cord.

MOUNTING INSTRUCTIONS

Refer to rough-in for location of plumbing and electrical sources. The support frame is to be installed first. Hang upper panel to hanger on frame. Fountain is to be attached to panel and wall frame. Water service line, waste line and electrical are assembled as required. Perform a final check for leaks and correct functions of fountains and chiller. (For details see the installation instructions.)

Installation requires trap to be installed in wall. Trap and service stop not included.

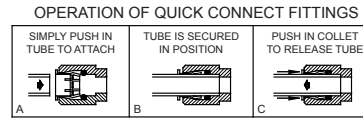

PUSHING TUBE IN BEFORE PULLING IT OUT HELPS TO RELEASE TUBE

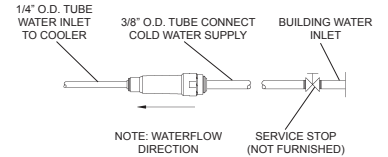

WALL LAYOUT

5/16" SCREWS OR BOLTS (10 REQ'D - NOT FURNISHED)

INSTALL 2 SCREWS (P/N 111008343890) IN FRAME BEFORE INSTALLING IN OPENING

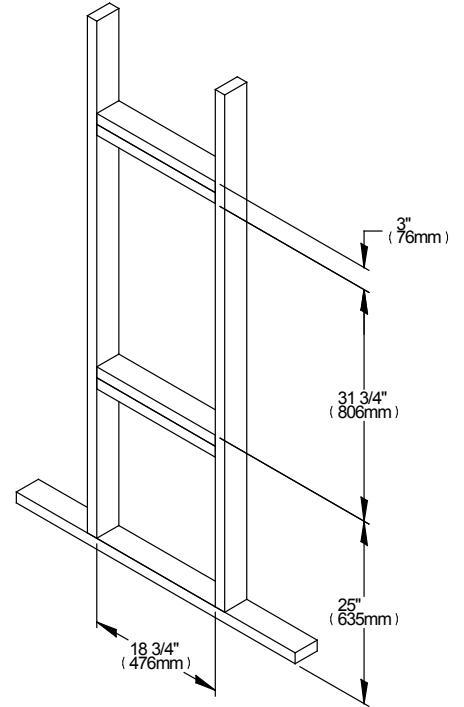

Job Name: _____
 Date: _____ Qty. _____
 Contact Info (Name, Phone, Email): _____

 Approval: _____

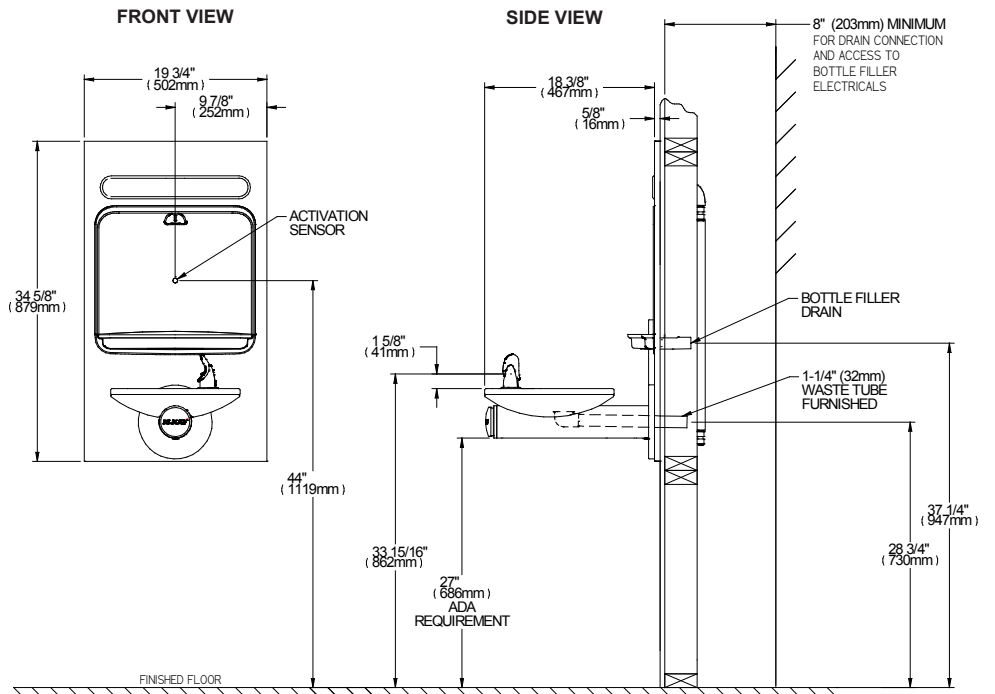

REDUCE HEIGHT BY 3 INCHES FOR INSTALLATION OF CHILDREN'S ADA FOUNTAIN