

Model: PFUPPP2528251M10

Features:

Portable submersible utility pump for water removal or emptying shallow flooded areas.

- **DISCHARGE:** 1" NPTM, Vertical, with 3/4" Garden Hose Adapter
- **LIQUID TEMPERATURE:** 32°-77°F
- **MOTOR HOUSING:** Corrosion-resistant, reinforced Thermoplastic with T-Handle for easy portability.
- **IMPELLER:** Corrosion-resistant, reinforced Thermoplastic
- **SUCTION PLATE:** Corrosion-resistant, reinforced Thermoplastic, Bottom suction design filters debris and removes water down to 1/8"
- **SHAFT:** Stainless Steel
- **HARDWARE:** Stainless steel
- **GASKET:** Rubber
- **SEAL:** Single mechanical, rubber and stainless steel
- **UPPER BEARING:** Single row, ball, oil lubricated
- **LOWER BEARING:** Single row, ball, oil lubricated
- **POWER CORD:** SJTW, 18AWG/3C Cord, with plug. 10 ft long
- **MOTOR:** Energy efficient Permanent Split Capacitor (PSC), Oil Filled, Class B insulation, Continuous duty (water depth must be at least 6" to prevent motor from overheating), Auto reset thermal overload protector, Circuit requirements 10 AMPS.
- **WARRANTY:** 3 year



**Submersible Utility Pump
1" NPT Discharge,
1/8" Spherical Solids
Manual Operation**



MODEL	HP	Hz	Volts/Ph	RPM	FL AMPS	Cord Length	Wt.
PFUPPP2528251M10	1/4	60	115/1	3450	2.3	10 ft	4.8 lbs

HEAD in Ft	0 Ft	5 Ft	10 Ft	15 Ft	20 Ft	25 Ft	Max Lift	Max Pressure
FLOW Gallon/Minute	25	23	20	16	13	8	28 Ft	12.4 psi
FLOW Gallon/Hour	1500	1370	1190	960	780	500		



PF	TYPE U, SP, SW	Motor Housing P, C	Impeller Type P, C	Suction Plate Type P, C	Motor HP 25, 33, 50, 75, 1	30	50	Voltage 1 or 2	Float Switch Type M, F, T	Cord Length 10, 15
Power-Flo	U = Utility SP = Sump Pump SW = Sewage Pump	P = Plastic C = Cast Iron	P = Plastic C = Cast Iron	P = Plastic C = Cast Iron	25 = 1/4 HP 33 = 1/3 HP 50 = 1/2 HP 75 = 3/4 HP 1 = 1 HP	Shut Off Head (ft)	Max Flow (Gal)	1 = 115 V 2 = 230V	M = Manual F = Fixed Vertical T = Tethered	10 Ft 25 Ft

EXAMPLE: PFSPCPC3330501T10 - Power-Flo Pumps - Sump Pump - Cast Iron Motor Housing - Plastic Impeller - Cast Iron Suction Plate - 1/3HP - 30" Shut Off Head - 50GPM Max Flow - 115 Volt - Tethered Float - 10' Cord



Sump, Sewage, & Utility Pumps - 1/4HP - 115V - Thermoplastic

Model: PFUPPP2528251M10

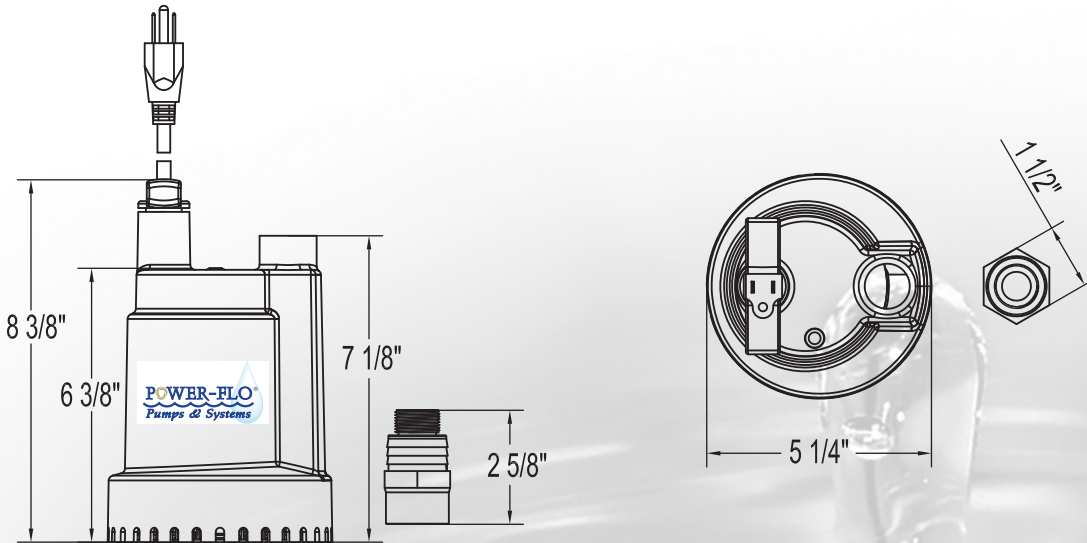
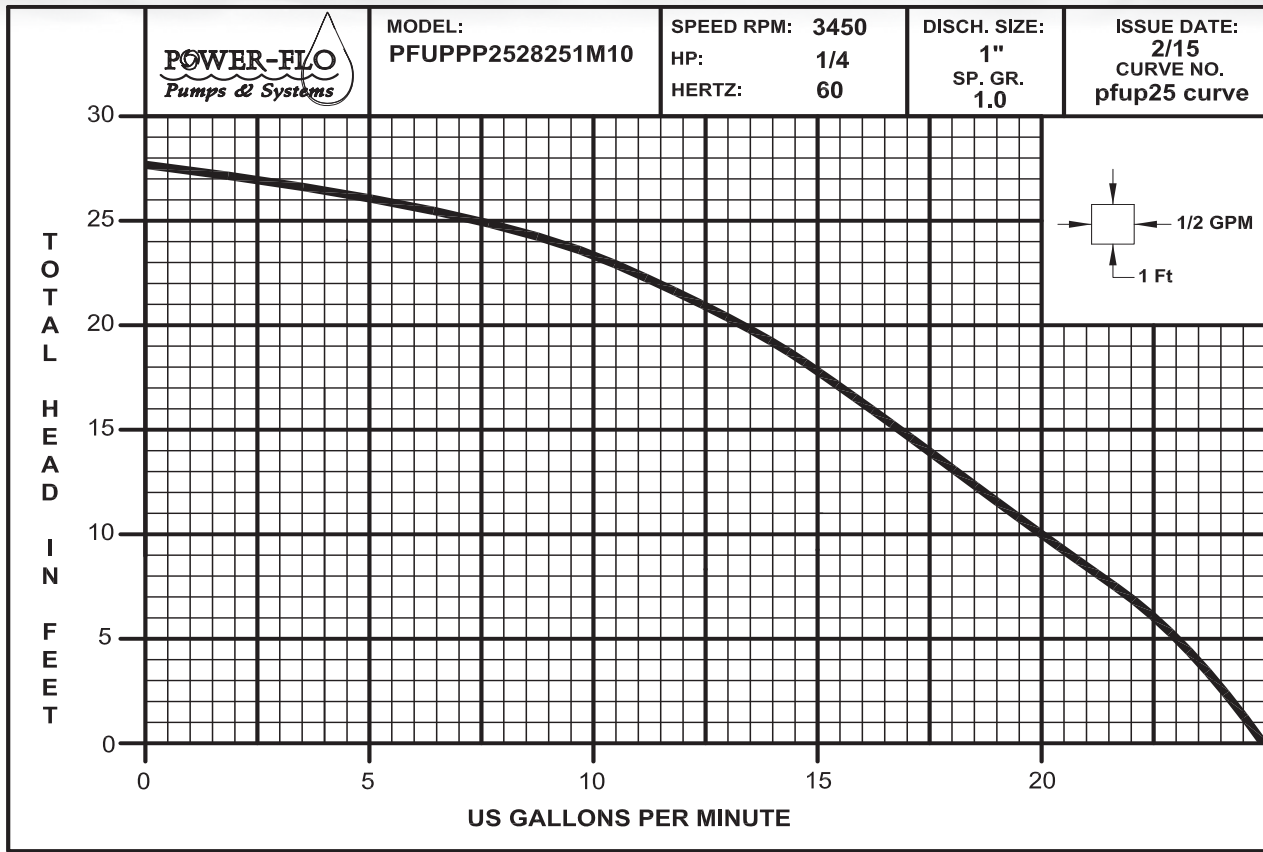

PF	TYPE U, SP, SW	Motor Housing P, C	Impeller Type P, C	Suction Plate Type P, C	Motor HP 25, 33, 50, 75, 1	30	50	Voltage 1 or 2	Float Switch Type M, F, T	Cord Length 10, 15
Power-Flo	U = Utility SP = Sump Pump SW = Sewage Pump	P = Plastic C = Cast Iron	P = Plastic C = Cast Iron	P = Plastic C = Cast Iron	25 = 1/4 HP 33 = 1/3 HP 50 = 1/2 HP 75 = 3/4 HP 1 = 1 HP	Shut Off Head (ft)	Max Flow (Gal)	1 = 115 V 2 = 230V	M = Manual F = Fixed Vertical T = Tethered	10 Ft 20 Ft

EXAMPLE: PFSPCPC3330501T10 - Power-Flo Pumps - Sump Pump - Cast Iron Motor Housing - Plastic Impeller - Cast Iron Suction Plate - 1/3HP - 30" Shut Off Head - 50GPM Max Flow - 115 Volt - Tethered Float - 10' Cord

