

English

ASSEMBLY INSTRUCTIONS

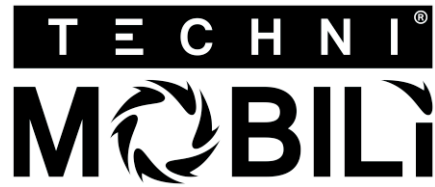

MODEL RTA - 2706A

Thanks for purchasing one of our products.
Please read carefully the assembly instructions before the installation.
Please save this manual for future reference.

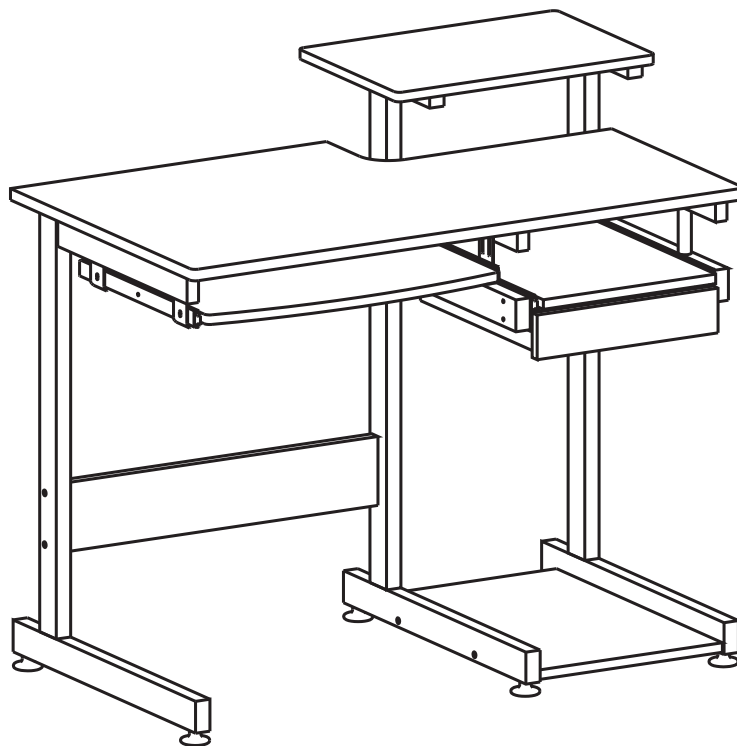

MODEL RTA-2706A



Spanish

INSTRUCCIONES DE ENSAMBLAJE.

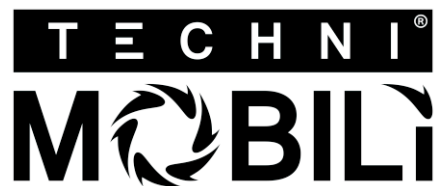

MODELO RTA - 2706A

Gracias por comprar uno de nuestros productos.
Por favor lea cuidadosamente las instrucciones de ensamblaje antes de instalar la unidad.
Por favor guarde este manual para referencias futuras.

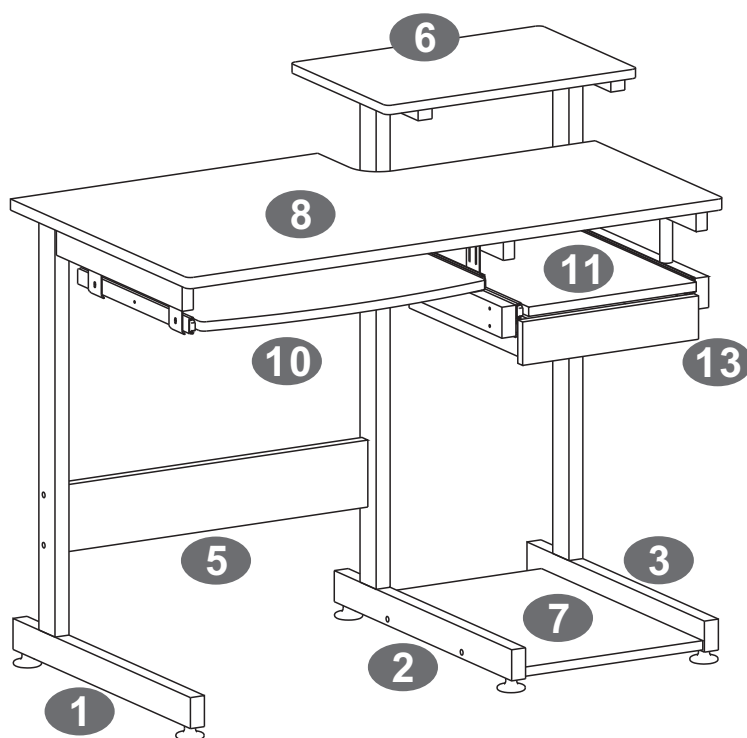

MODELO RTA-2706A

RTA-2706A

DIMENSIONS

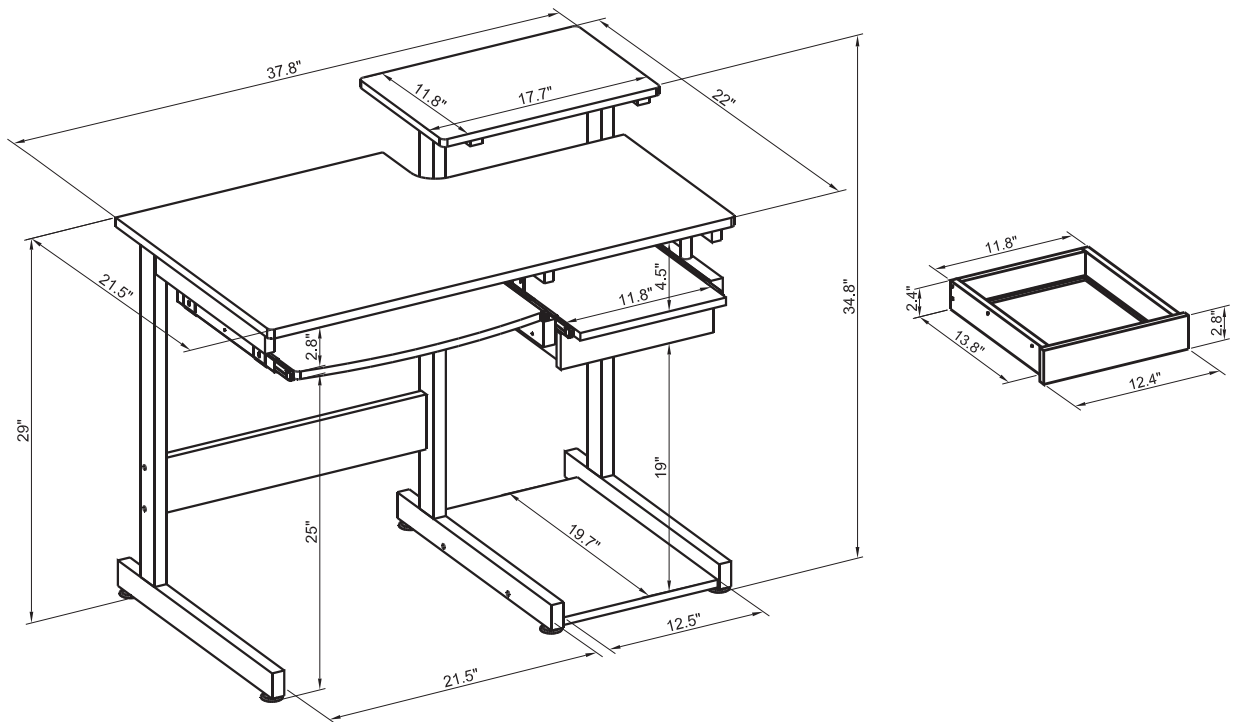

Product Size: 37.8"W x 22"D x 34.8"H

MAXIMUM WEIGHT CAPACITIES

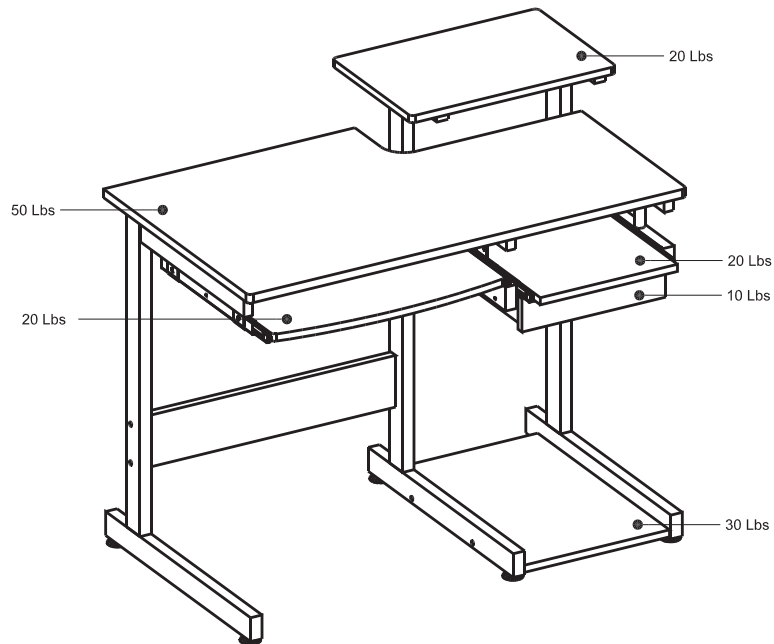

DO NOT exceed this limit
Please use care and good judgement
when placing objects on wood surface

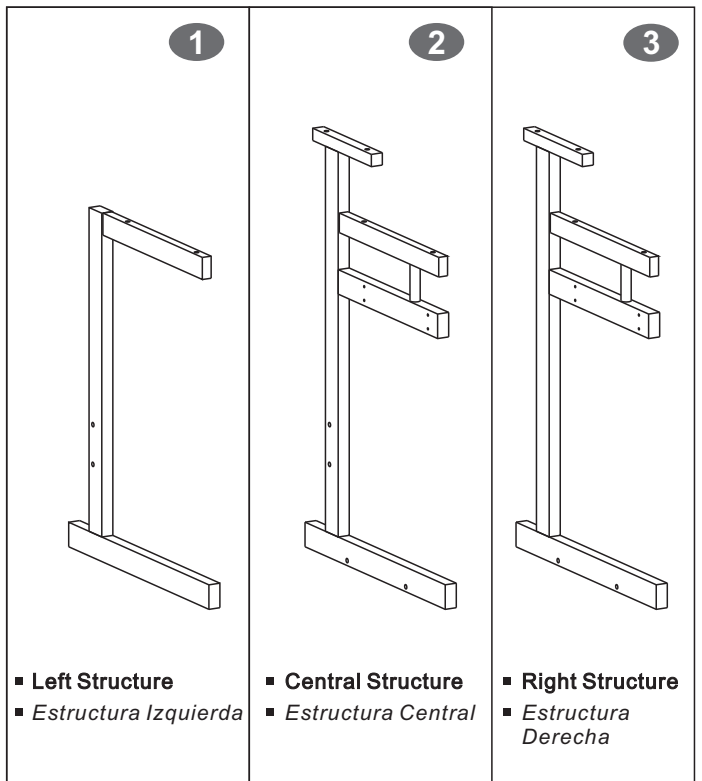
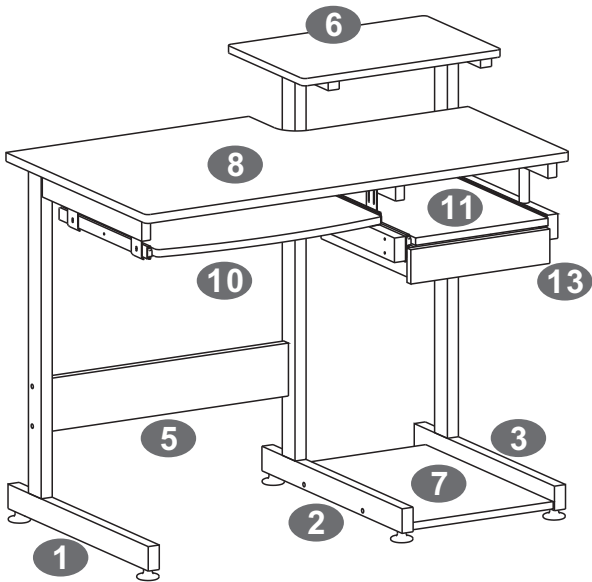

▪ PARTS LIST ▪ LISTA DE PARTES





<p>4</p> <p>X6</p> <ul style="list-style-type: none"> ▪ Studs ▪ Topes 	<p>5</p> <ul style="list-style-type: none"> ▪ Back Panel ▪ Panel Posterior 	<p>6</p> <ul style="list-style-type: none"> ▪ Monitor Panel ▪ Panel de Monitor 	<p>7</p> <ul style="list-style-type: none"> ▪ CPU Panel ▪ Panel Para Cpu
<p>8</p> <ul style="list-style-type: none"> ▪ Main Panel ▪ Panel Principal 		<p>9</p> <p>X4</p> <ul style="list-style-type: none"> ▪ Hooks ▪ Bases 	
<p>11</p> <ul style="list-style-type: none"> ▪ Auxiliary Panel ▪ Panel Auxiliar 		<p>13</p> <ul style="list-style-type: none"> ▪ Drawer ▪ Gaveta 	<p>14</p> <p>2SETS</p> <p>Derecho Right</p> <p>Left Izquierdo</p> <ul style="list-style-type: none"> ▪ Sliders ▪ Deslizadores
<p>12</p> <p>1 SET</p> <ul style="list-style-type: none"> ▪ Slider For Drawer ▪ Deslizadores para gaveta 			

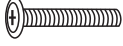
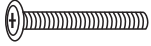

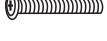
▪ SCREWS ▪ TORNILLOS

PART	QTY.	ITEM	
A	4	6X35 MM	
B	14	6X50 MM	
C	8	4X14 MM	
D	4	4X4 MM	
E	8	4X28 MM	

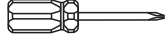
PART	QTY.	ITEM	
F	4	3X15 MM	
G	4	6X12 MM	
	1		



GENERAL ASSEMBLY TIPS AND TROUBLESHOOTING DURING ASSEMBLY:

- *Before you start assembling, make sure you have all the parts and necessary hardware by doing a quick inventory.**
- *Follow the assembly instructions step by step, and do not skip any unless advised to do so by RTA PRODUCTS' Customer Service.**
- *On each step, and to avoid misalignments, always leave screws loose, and do not tighten them until all are in place.**
- *In wood panels, the laminate might be covering the holes.**
If there are no visible holes: Pass the tip of your finger around the area where the hole should be, and press against the surface to feel the indentation.
If the hole looks too small for the screw or bolt: carefully perforate the laminate with the tip of a pen.

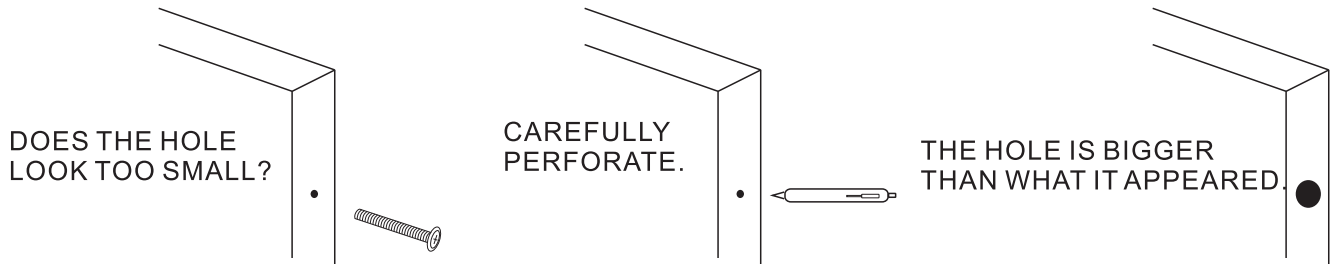

- *In wood panels, some might have inserts that look like screws. Those inserts are either nuts or cam locks. Make sure they are aligned to receive the screws or bolts.**

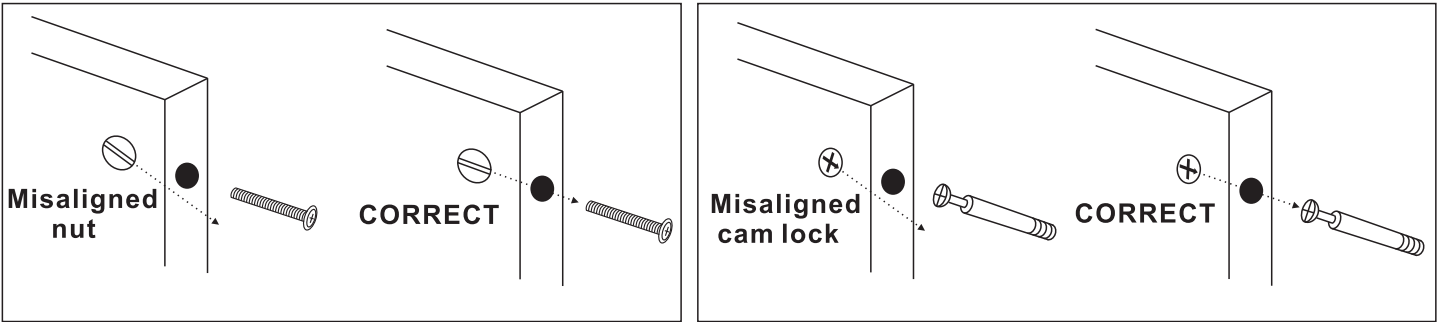

- *Make sure to use the correct screws or bolts, and do not overtighten them. Using wrong screws or overtightening them might cause damage to the parts, and such damage is not covered by the product's warranty.**

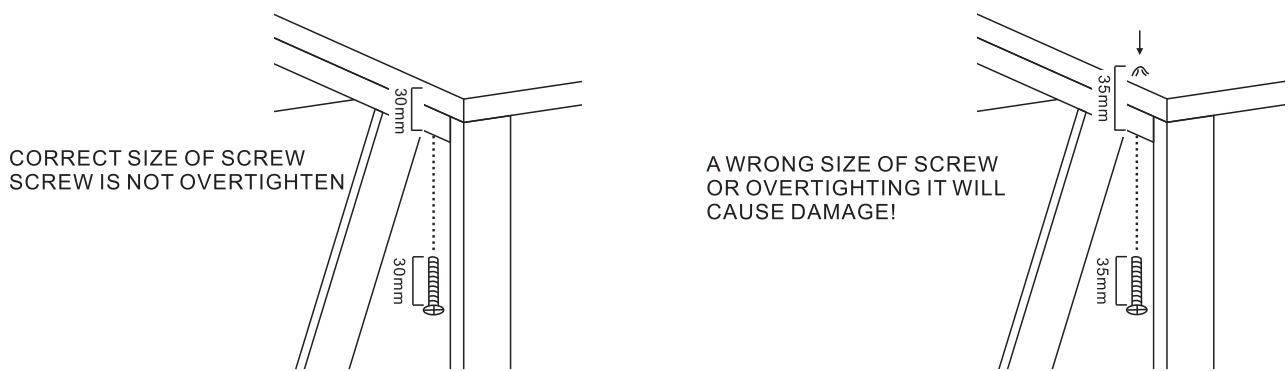

**CONSEJOS PARA RESOLVER PROBLEMAS DURANTE EL ENSAMBLAJE:**

- *Antes de comenzar, haga un inventario rápido para asegurarse de tener todas las partes y tornillos necesarios.
- *Siga las instrucciones paso por paso, y no se salte ninguno a menos que se lo aconseje un representante de Servicio al Cliente de RTA PRODUCTS.
- *Para evitar desalineamientos, en cada paso que haga deje los tornillos medio puestos, y no los apriete hasta que todos estén colocados en sus lugares.
- *En paneles de madera, el laminado podría cubrir las perforaciones.
Si no ve los hoyos: Pase la punta del dedo por el area y presione contra la superficie para encontrar el hoyo.
Si el hoyo luce muy pequeño para el tornillo o perno: Con cuidado perforo el laminado con la punta de un lapicero (bolígrafo, pluma).

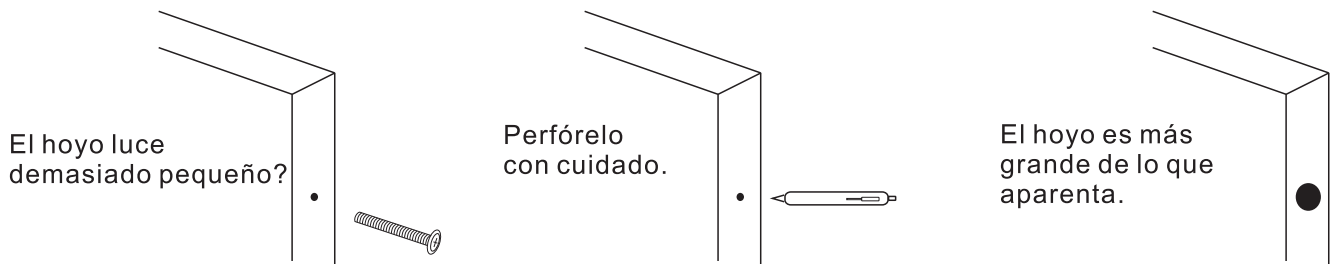

- *Algunos paneles pueden tener insertados lo que parecen tornillos, pero son tuercas o cerrajes: Asegúrese que estén alineados para recibir el tornillo o perno.

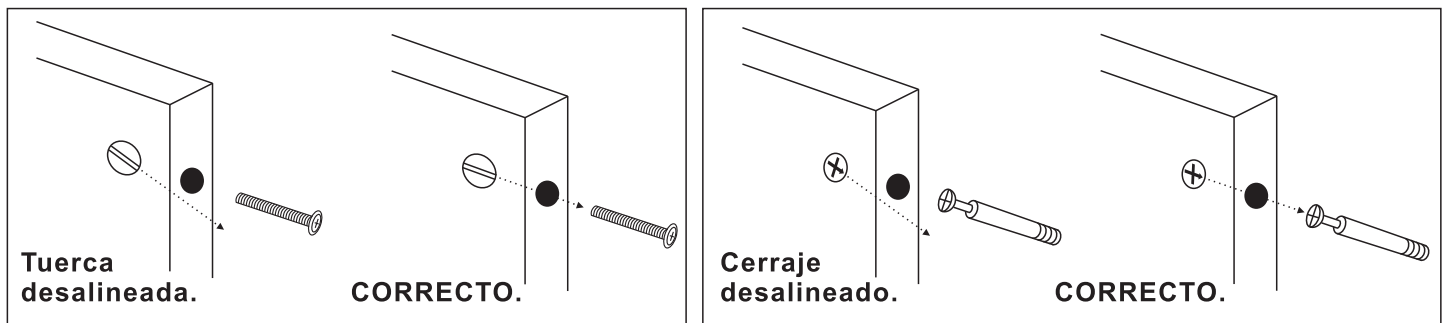

- *Asegúrese de usar los tornillos y pernos correctos, y no los apriete demasiado. Usar tornillos/pernos de tamaño incorrecto o sobre-apretarlos puede causar daño a las partes, lo cual no es cubierto por la garantía del producto.

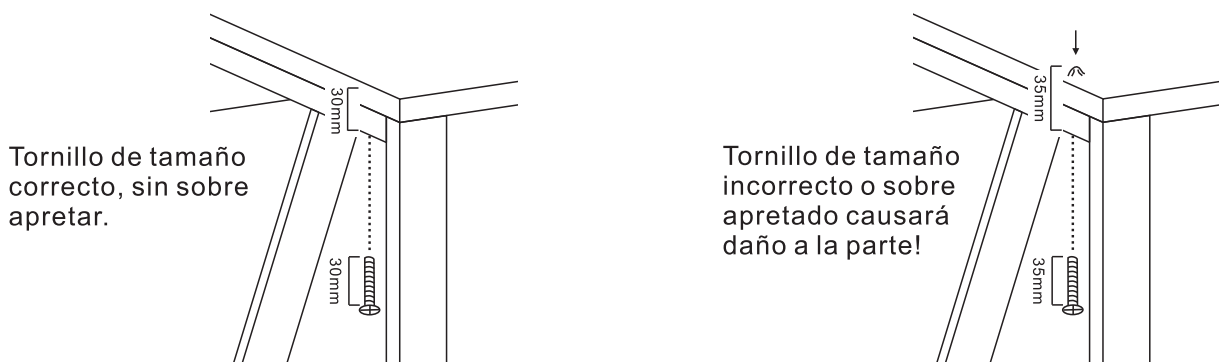

▪ STEPS

▪ PASOS

1

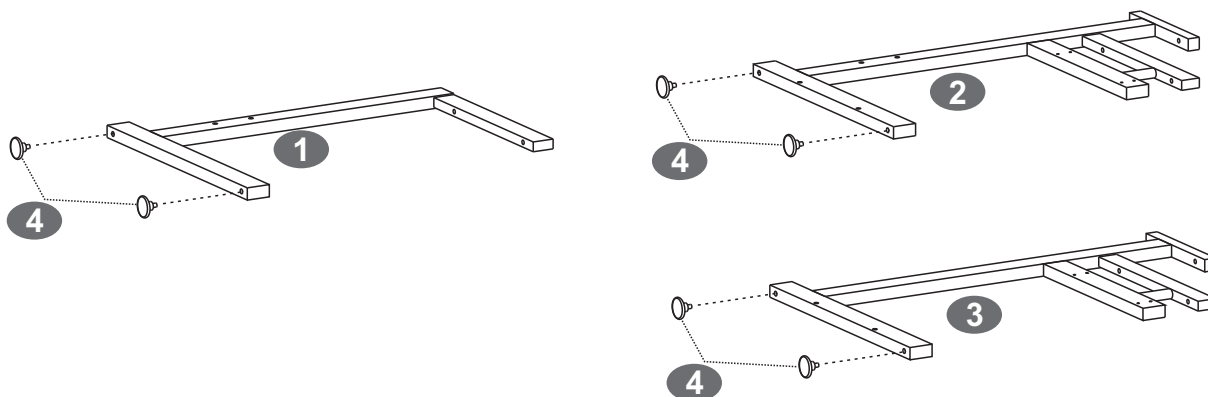

- Insert the Studs (4) at the bottom of the Left, Central & Right Structures (1,2&3).
- Inserte los topes (4) en las patas de las estructuras izquierda, derecha y central (1,2,3).

2

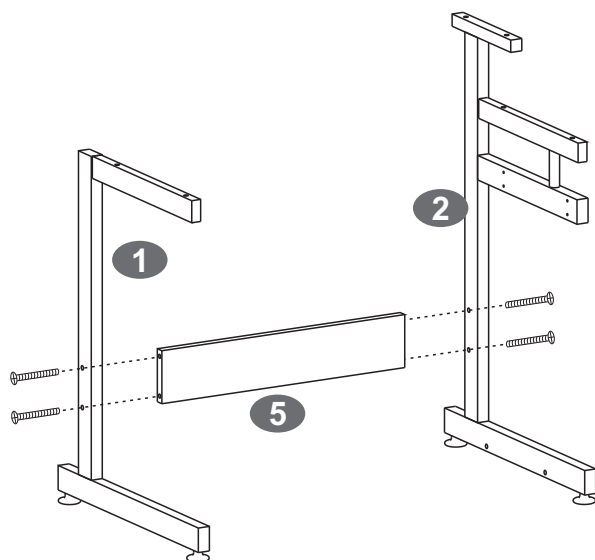

Before doing this step, make sure that all the nuts in the panel are properly aligned to receive the screws!

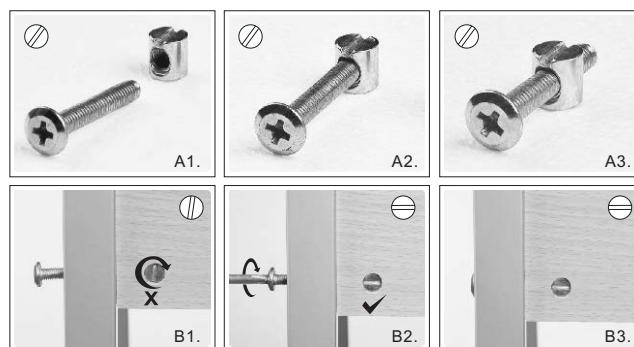

Antes de hacer este paso, asegúrese que las tuercas en el panel estén alineadas para recibir los tornillos!

▪ SCREWS ▪ TORNILLOS

B 6X50 MM

4PCS



- Use screws B to assemble the Back Panel (5) between the Left & Central Structures (1 & 2).
- Use tornillos B para ensamblar el panel posterior (5) entre las estructuras central e izquierda (1, 2).

3

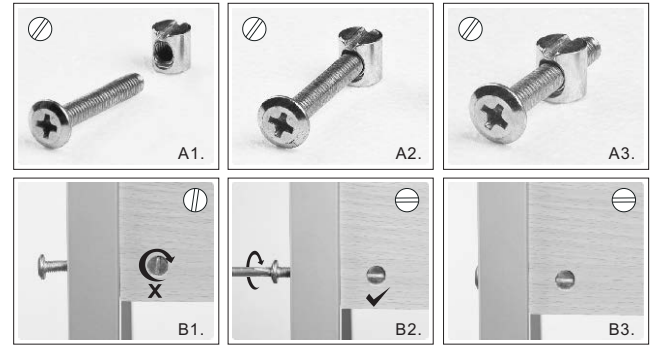
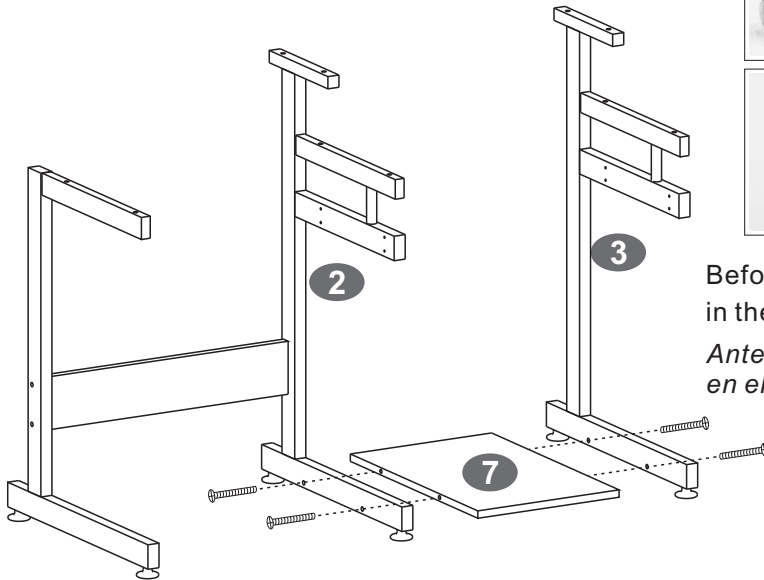

Before doing this step, make sure that all the nuts in the panel are properly aligned to receive the screws!

Antes de hacer este paso, asegúrese que las tuercas en el panel estén alineadas para recibir los tornillos!

▪ SCREWS ▪ TORNILLOS

B 6X50 MM

4PCS



- Use screws B to assemble the CPU Panel (7) between the Central and Right Structure (2&3).
- Use tornillos B para ensamblar el Panel de Cpu (7) entre las estructuras Central y Derecha y así quedaran conectadas las (3) estructuras.

4

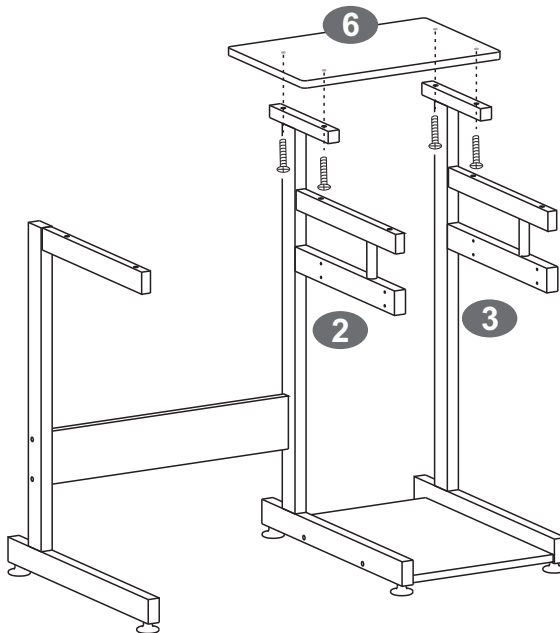

▪ SCREWS ▪ TORNILLOS

A 6X35 MM

4PCS



- Use screws A to fix the Monitor Panel (6) to Central & Right Structure (2&3).
- Use tornillos A para ensamblar el Panel para Monitor (6) a las estructuras derecha y central (2,3).

5

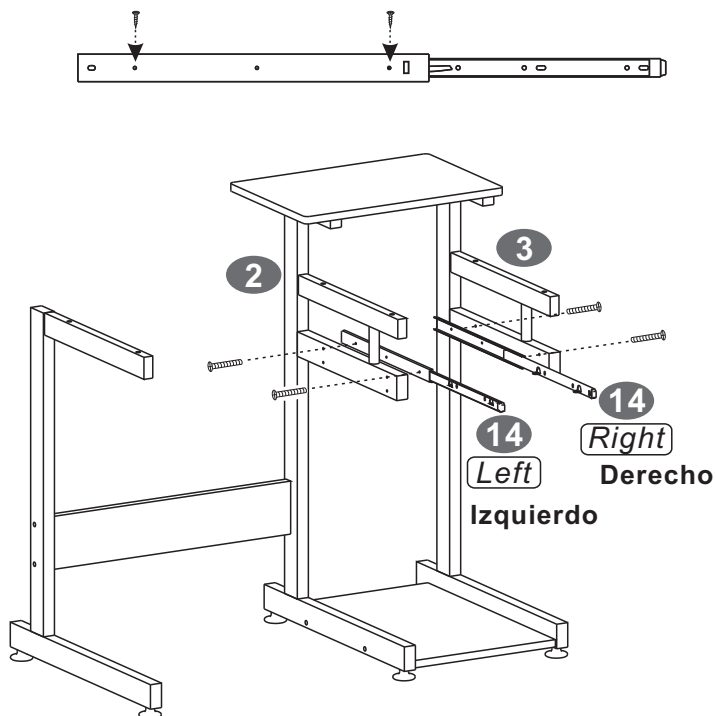

▪ SCREWS ▪ TORNILLOS

E 4X28 MM

4PCS



- Use screws E to assemble one pair of Sliders (14) to the Central & Right Structures (2&3) noting that they must slide-out to the front of the desk. You will find four holes in the metal structures, use the top two.
- Use Tornillos E para fijar el lado grueso de dos de los deslizadores (14) a las Estructuras derecha y central (2,3) tomando en cuenta que deben poder deslizarse hacia el frente del mueble. En la estructura encontrara 4 huecos de cada lado, use los de arriba.

6

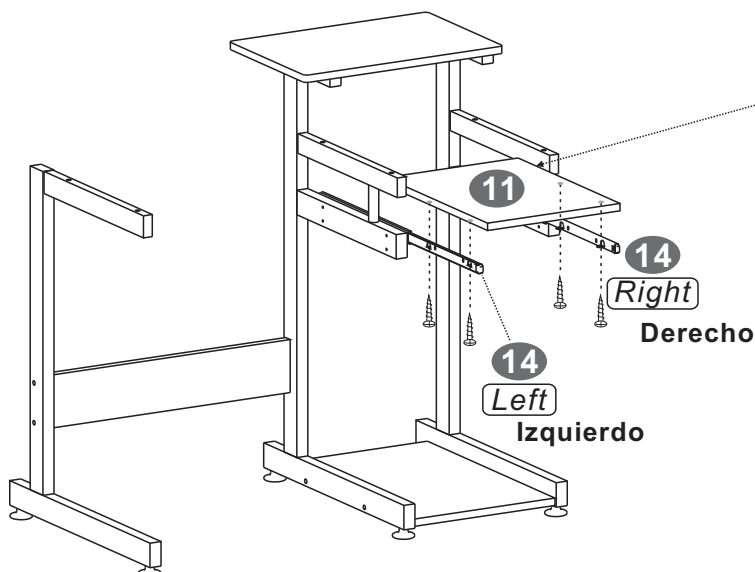

▪ SCREWS ▪ TORNILLOS

C 4X14 MM

4PCS



- Use screws C to fix the back face of the Auxiliary Panel (11) to the Sliders (14).
- Con tornillos C y por la cara posterior del panel Auxiliar (11) fijelo a los deslizadores (14).

7

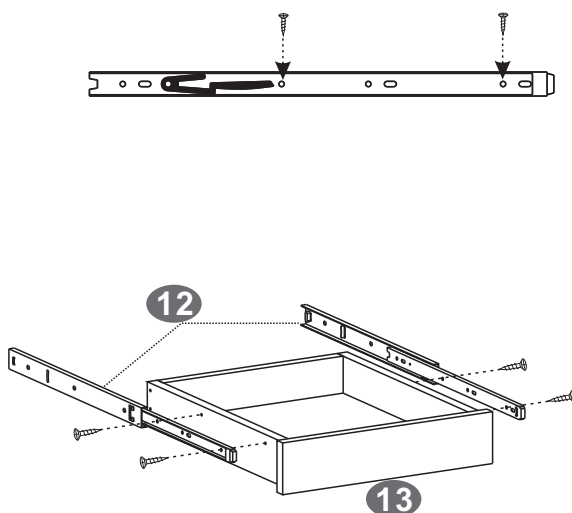

▪ SCREWS ▪ TORNILLOS

F 3X15 MM

4PCS



- Use screws F to assemble the thinner part of the Sliders (12) to the Drawer (13).
- Use tornillos F para fijar los deslizadores de gaveta (12) a la Gaveta (13), note que debe fijar la parte delgada del deslizador.

8

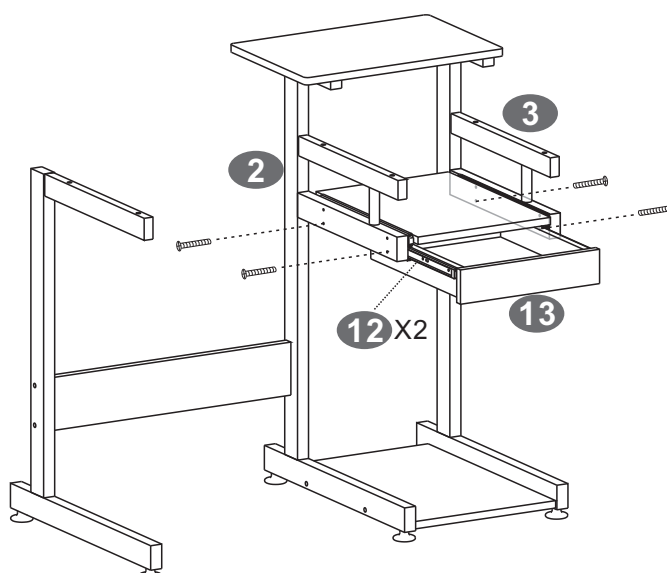

▪ SCREWS ▪ TORNILLOS

E 4X28 MM

4PCS



- Use screws E to assemble the wider part of the Drawer's sliders (12) to the Central & Right Structures (2&3).
- Con tornillos E fije la parte gruesa de los deslizadores de Gaveta (12) a las estructuras derecha y central (2,3).

9

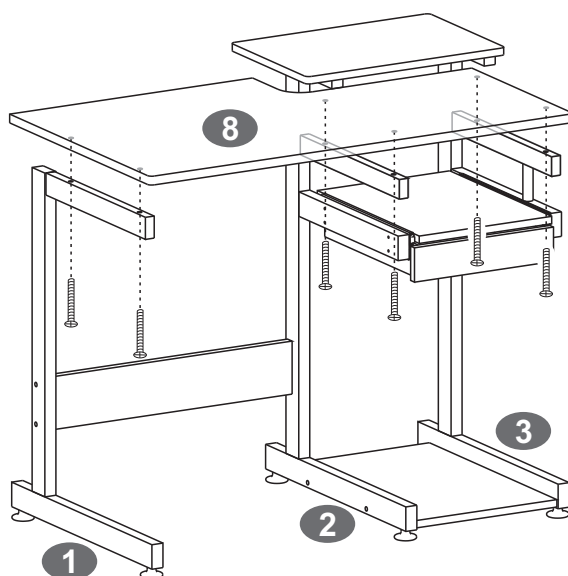

▪ SCREWS ▪ TORNILLOS

B 6X50 MM

 6PCS



- Use screws **B** to assemble the back face of the Main Panel (8) to the Main Structures (1,2&3).
- Use tornillos **B** para fijar el Panel Principal (8) a las estructuras derecha, izquierda y central (1,2,3).

10

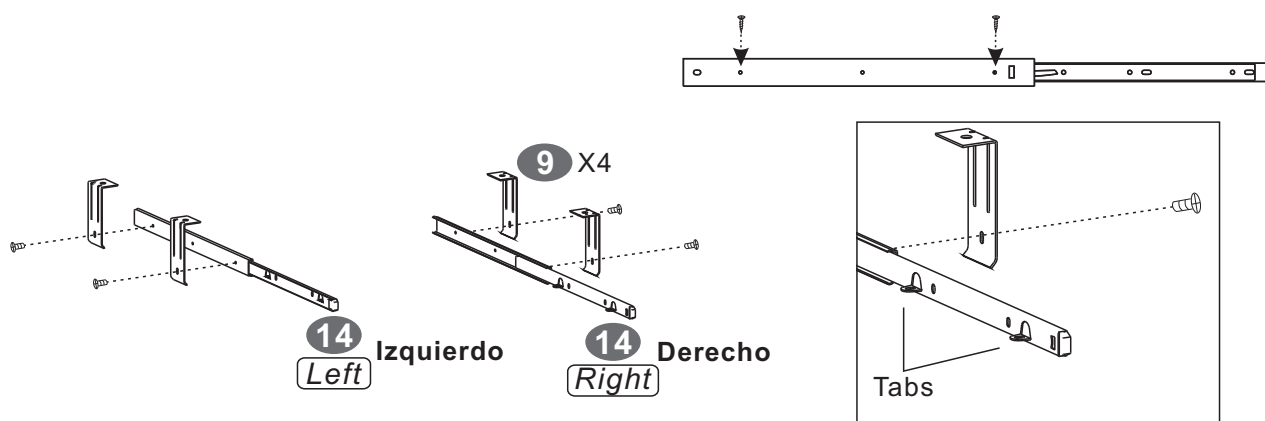

▪ SCREWS ▪ TORNILLOS

D 4X4 MM

 4PCS



- Use screws **D** to fix the Hooks (9) to the other pair of Sliders (14).
- Use Tornillos **D** para fijar la parte gruesa de los otros dos deslizadores (14) a las bases (9).

11

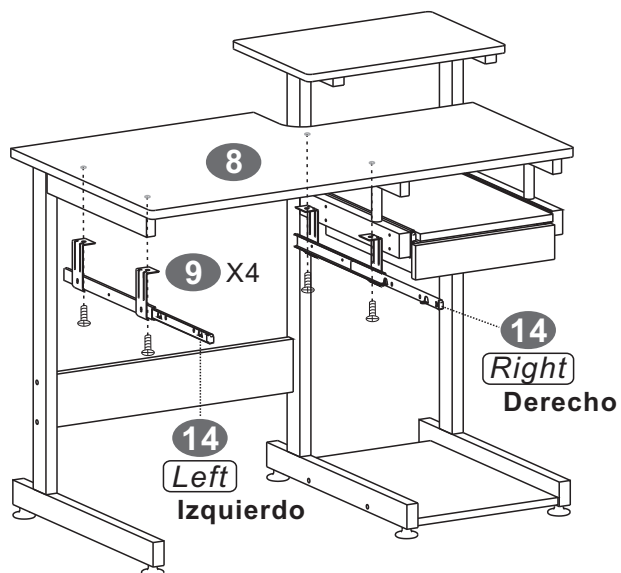

- Use screws G to fix the Hooks (9) to the underside of the Main Panel.
- Use tornillos G para fijar las bases (9) a la parte inferior del Panel Principal (8).

▪ SCREWS ▪ TORNILLOS

G 6X12 MM

4PCS



12

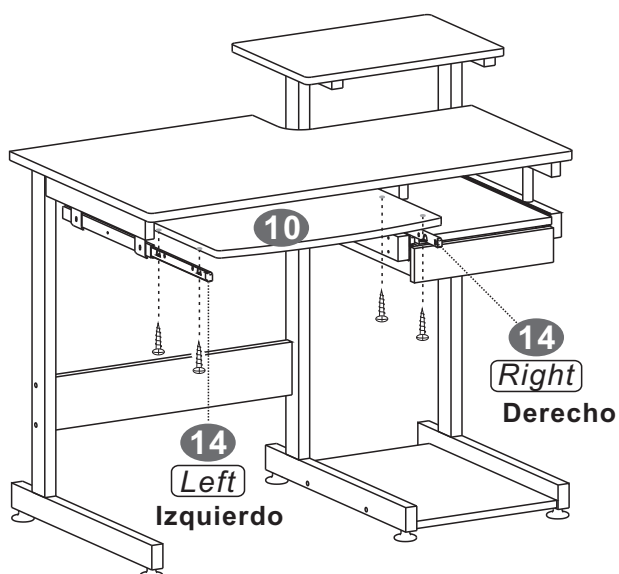

- Use screws C to assemble the back face of the Keyboard Panel (10) to the Sliders (14).
- Con tornillos C y por debajo, ensamble el Panel de Teclado (10) con los deslizadores (14).

▪ SCREWS ▪ TORNILLOS

C 4X14 MM

4PCS



CARE AND MAINTENANCE

English

- DO NOT EXPOSE THE SURFACES TO DIRECT SUNLIGHT, OR EXTREME ENVIRONMENTAL CONDITIONS. EXPOSURE WILL DAMAGE THE PRODUCT, WHICH IS NOT COVERED BY THE WARRANTY.
- DO NOT USE SOLVENTS OVER SURFACES OR STRUCTURAL TUBES. SURFACES MUST BE CLEANED WITH A SOLUTION OF A SMOOTH SOAP AND WATER, THEN CLEARED WITH A DRY TOWEL.
- PRODUCTS THAT ARE HEAVY SHOULD BE LIFTED OR MOVED BY AT LEAST 2 PERSONS, AND ALL OBJECTS SHOULD BE REMOVED FROM THE PRODUCT.

Spanish

- NO EXPONGA LAS SUPERFICIES A LA LUZ SOLAR DIRECTA, O A CONDICIONES AMBIENTALES EXTREMAS. ESTE TIPO DE DAÑOS NO SON CUBIERTOS POR LA GARANTÍA DEL PRODUCTO.
- NO USE SOLVENTES SOBRE LAS SUPERFICIES O TUBOS ESTRUCTURALES. LAS SUPERFICIES DEBEN SER LIMPIADOS CON UN JABÓN SUAVE Y AGUA, Y SECADOS INMEDIATAMENTE CON UNA TOALLA LIMPIA Y SECA.
- PRODUCTOS QUE SON PESADOS DEBEN LEVANTARSE O MOVERSE POR AL MENOS 2 PERSONAS, Y TODOS LOS OBJETOS DEBEN SER REMOVIDOS DEL PRODUCTO.