

English

ASSEMBLY INSTRUCTIONS

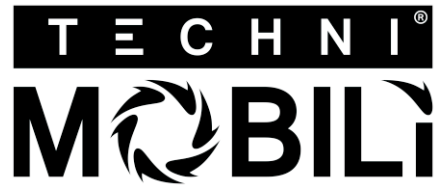

MODEL RTA - 3520

Thanks for purchasing one of our products.
Please read carefully the assembly instructions before the installation.
Please save this manual for future reference.



Complete video assembly demonstration is available at:
www.rtaproducts.com/assembly-videos.htm

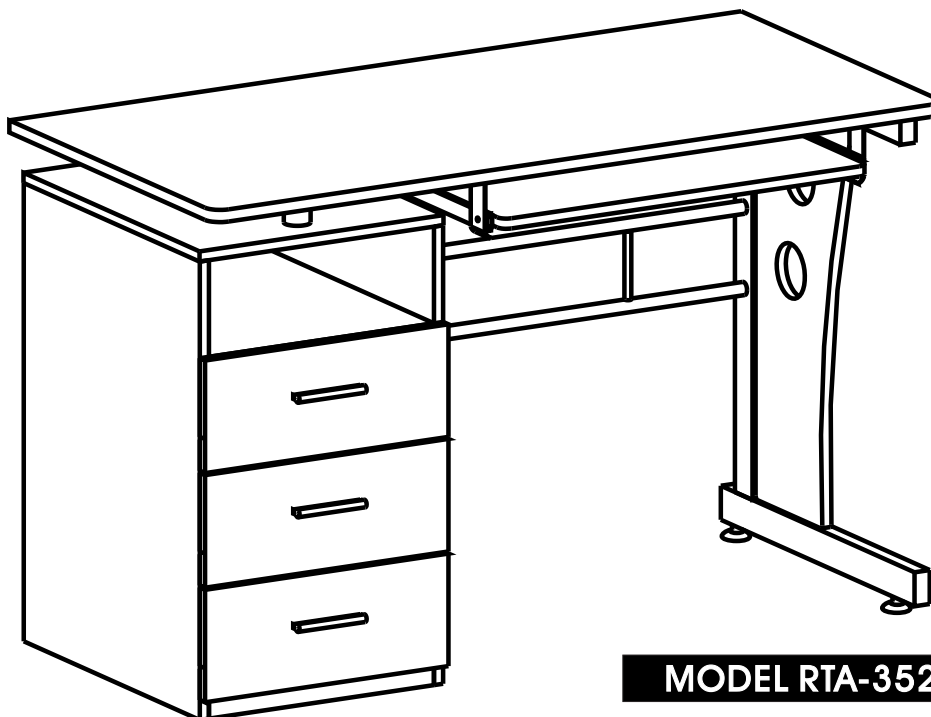

MODEL RTA-3520

RTA-3520

DIMENSIONS

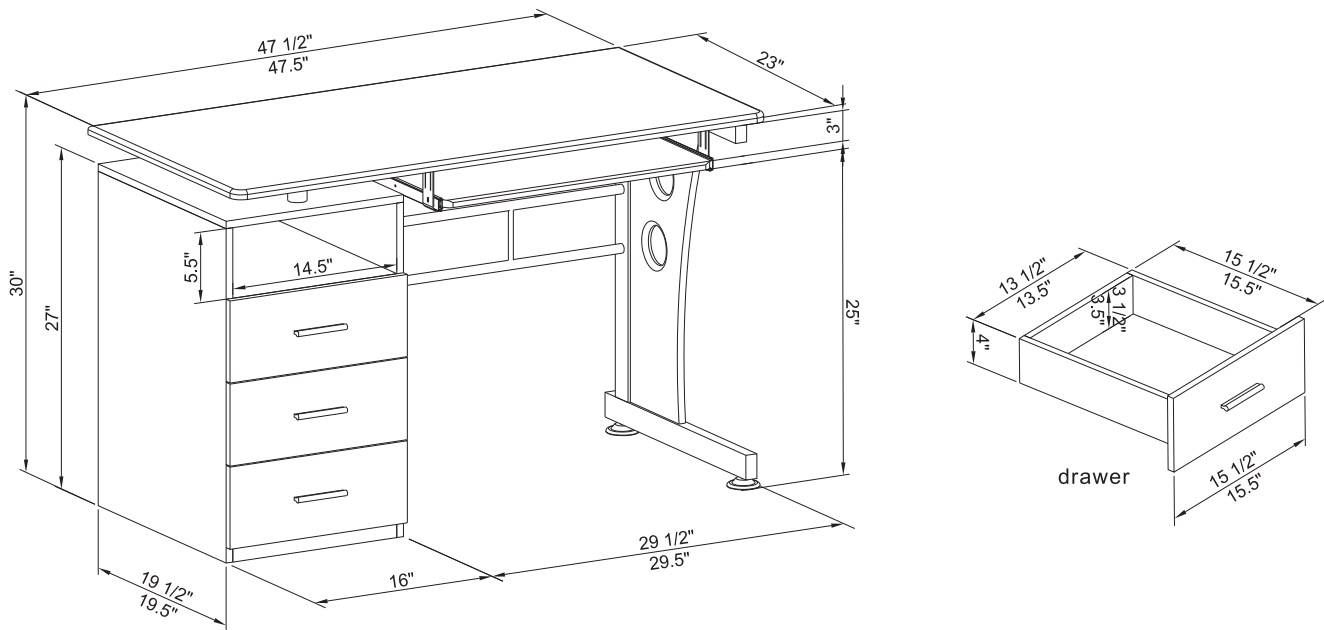

Product Size: 47.5"W x 23"D x 30"H

MAXIMUM WEIGHT CAPACITIES









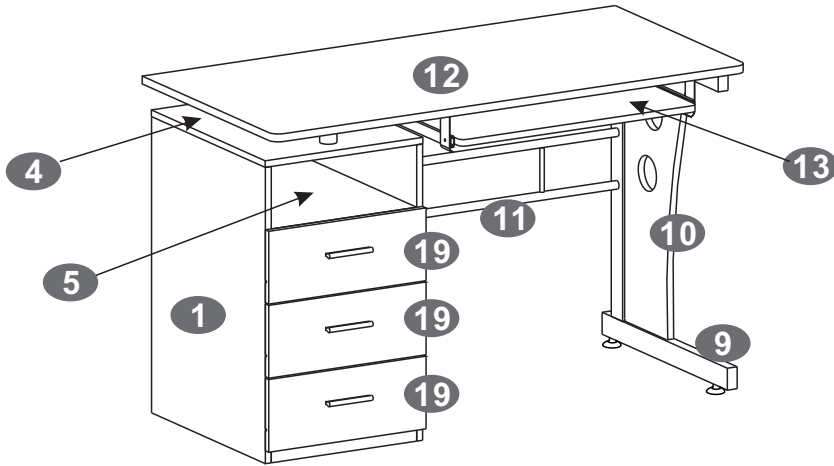



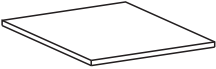

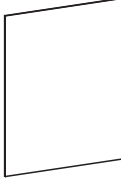
DO NOT exceed this limit
Please use care and good judgement
when placing objects on wood surface



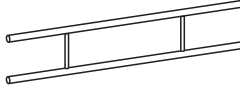

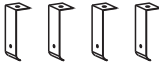
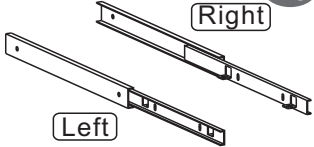

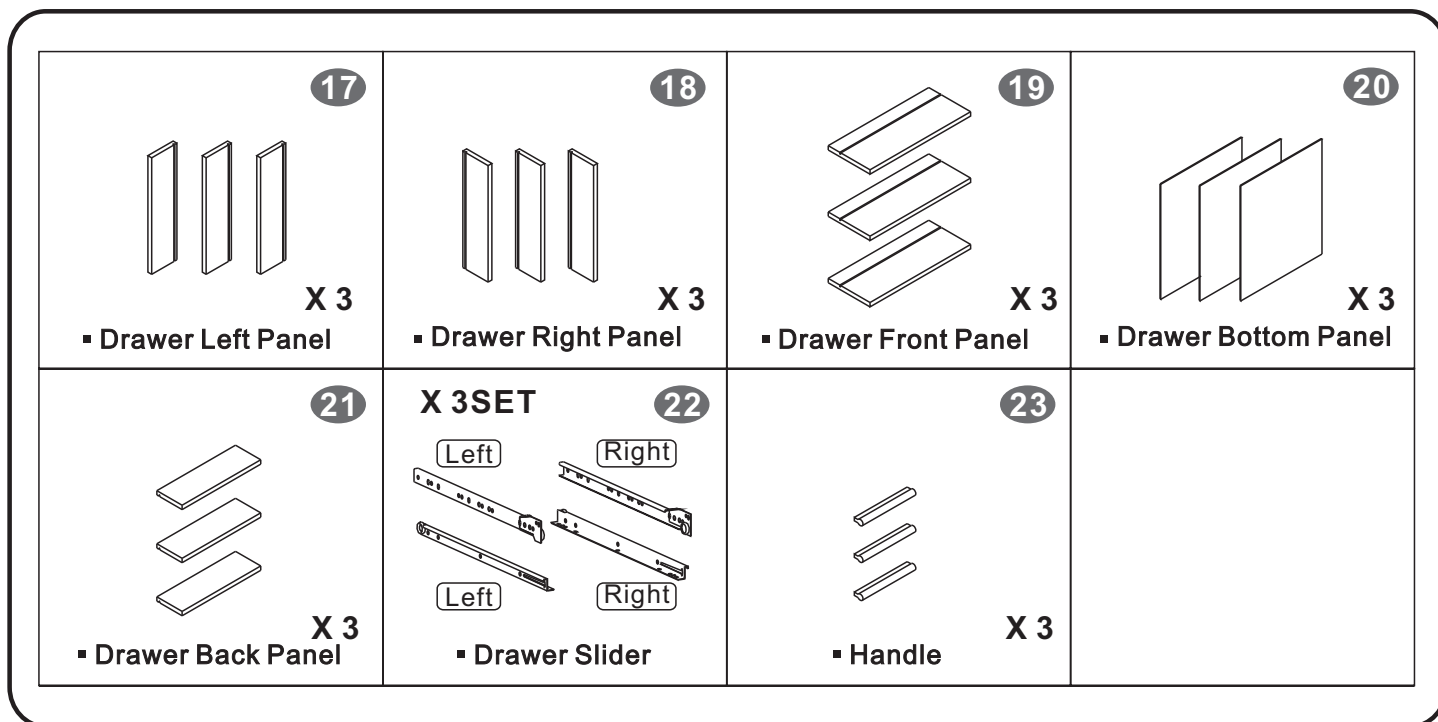

▪ PARTS LIST



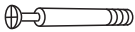



 <p>1 ▪ Left Panel</p>	 <p>2 ▪ Middle Panel</p>	 <p>3 ▪ Studs X 2</p>	 <p>4 ▪ Top Panel</p>
 <p>5 ▪ Horizontal Panel</p>	 <p>6 ▪ Bottom Panel</p>	 <p>7 ▪ Back Panel</p>	 <p>8 ▪ Front Base Panel</p>
 <p>9 ▪ Side Structure</p>	 <p>10 ▪ Right Panel</p>	 <p>11 ▪ Back Structure</p>	 <p>12 ▪ Main Panel</p>
 <p>13 ▪ Keyboard Panel</p>	 <p>14 ▪ Slider Base X 4</p>	 <p>15 ▪ Keyboard Slider X 1 SET Left Right</p>	 <p>16 ▪ Support Tubes X 2</p>



▪ SCREWS LIST

PART	QTY.	ITEM	
A	24	3X15 MM	
B	26	6X40 MM	
C	4	6X75 MM	
D	4	6X35 MM	
E	2	6X25 MM	
F	4	6X12 MM	
G	4	4X4 MM	
H	12	4X14 MM	

PART	QTY.	ITEM	
I	2	6X60 MM	
J	12	4X35 MM	
K	6	4X20 MM	
L	2		
	1		

HOW TO ASSEMBLE USING BOLTS AND CAM LOCKS:



▪ Cam bolt

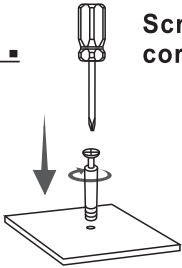

▪ Cam lock

1.

Screw the bolt into the corresponding panel.

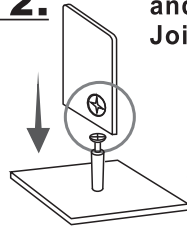
2.

In the other panel, insert and align the cam lock. Join the panels.

3.

Turn the cam lock.

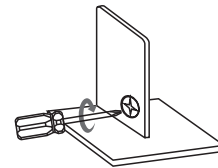

If the panel already comes with the cam lock inserted, make sure is aligned:

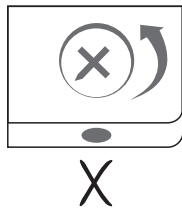
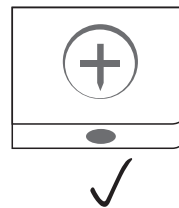
**MISALIGNED:
TURN CAM LOCK
TO POINT TOWARDS
THE HOLE****CORRECT**

GENERAL ASSEMBLY TIPS AND TROUBLESHOOTING DURING ASSEMBLY:

- *Before you start assembling, make sure you have all the parts and necessary hardware by doing a quick inventory.
- *Follow the assembly instructions step by step, and do not skip any unless advised to do so by RTA PRODUCTS' Customer Service.
- *On each step, and to avoid misalignments, always leave screws loose, and do not tighten them until all are in place.
- *In wood panels, the laminate might be covering the holes.
If there are no visible holes: Pass the tip of your finger around the area where the hole should be, and press against the surface to feel the indentation.
If the hole looks too small for the screw or bolt: carefully perforate the laminate with the tip of a pen.

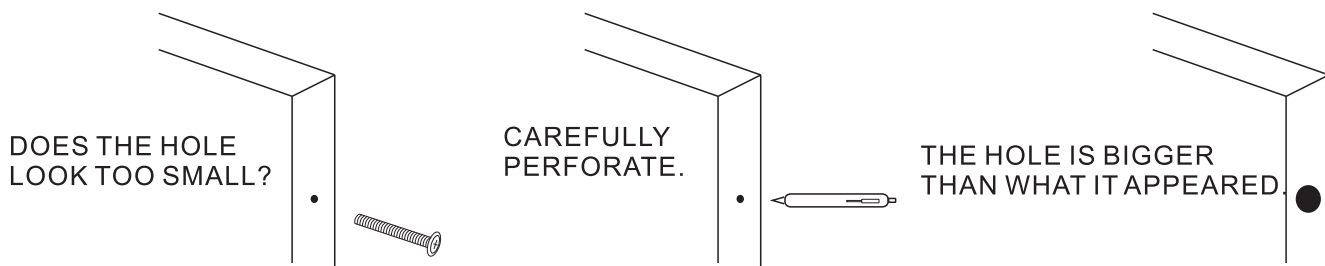

- *In wood panels, some might have inserts that look like screws. Those inserts are either nuts or cam locks. Make sure they are aligned to receive the screws or bolts.

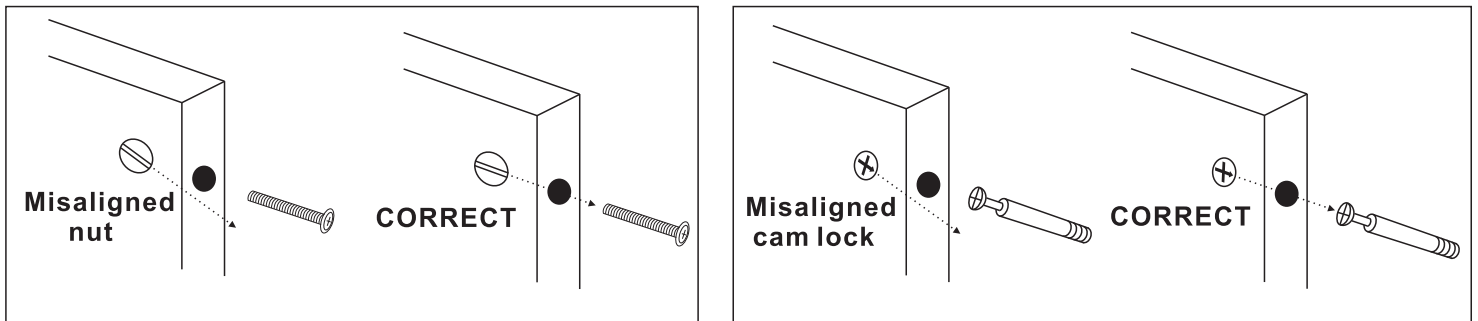

- *Make sure to use the correct screws or bolts, and do not overtighten them. Using wrong screws or overtightening them might cause damage to the parts, and such damage is not covered by the product's warranty.

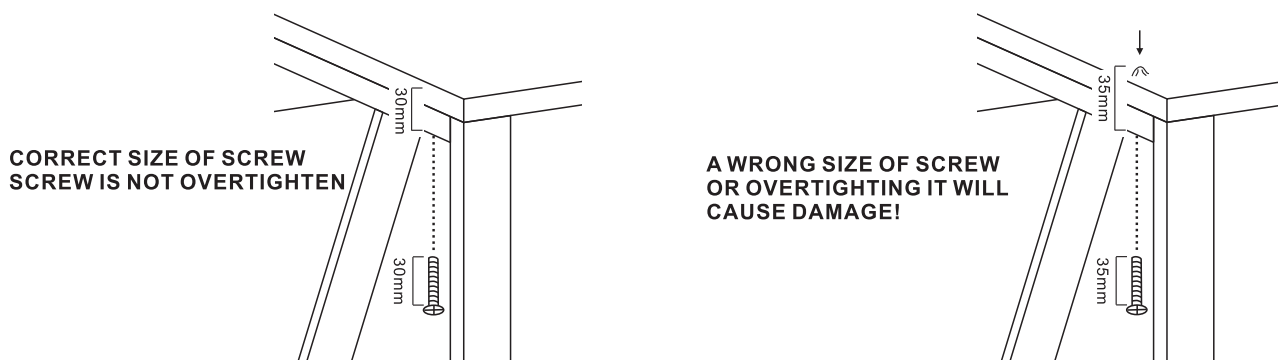



Complete video assembly demonstration is available at:
www.rtaproducts.com/assembly-videos.htm

▪ **ASSEMBLY STEPS:**

1

22 3PCS (Left)
 22 3PCS (Right)

▪ **SCREWS**
A 3X15 MM
 12PCS

▪ Grab all the flat shaped Drawer Sliders (22) and set aside the “L” shaped ones. With the Left & Middle Panels (1&2) oriented as illustrated, assemble the flat sliders (22) to the holes on their inside faces. The wheels will be located at the front and facing down.

2

6 8 5 6 8 1

TOP OF PANEL

1. 2. 3.

Detailed instructions on PAGE 5

▪ **SCREWS**
B 6X40 MM
 5PCS

▪ Join the Front Base Panel (8) to the Bottom Panel (6) by inserting the wood pins of (8) into the holes of (6) as shown. Screw the Bolts (B) to the corresponding holes on the inside face of Left Panel (1), then assemble to it the Horizontal Panel (5), Bottom Panel (6) and Small Front Panel (8) by turning all the corresponding cam locks.

3

7 5 6

▪ Slide in the Back Panel (7) thru the channels in between the Horizontal Panel (5) and Bottom Panel (6) as shown. Make sure the panel fits inside all the channels.

4

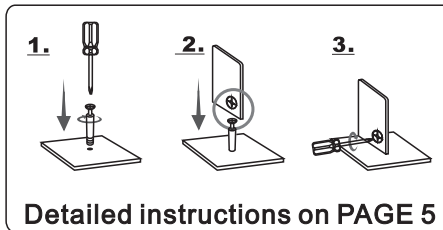
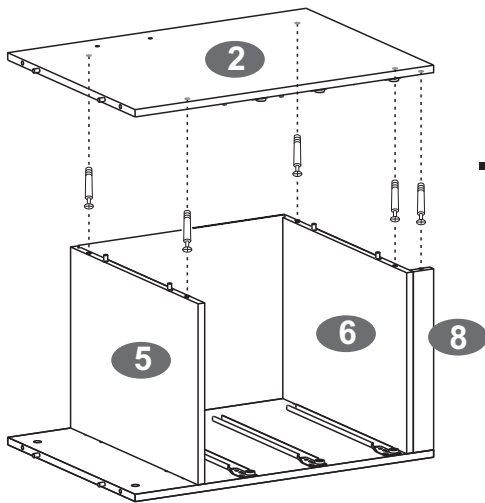

Detailed instructions on PAGE 5

- Screw the Bolts (B) to the corresponding holes on the inside face of Middle Panel (2), then assemble the Middle Panel (2) to the Horizontal Panel (5), Bottom Panel (6) and Front Base Panel (8) by turning all the corresponding cam locks.

▪ SCREWS

B 6X40 MM

5PCS



5

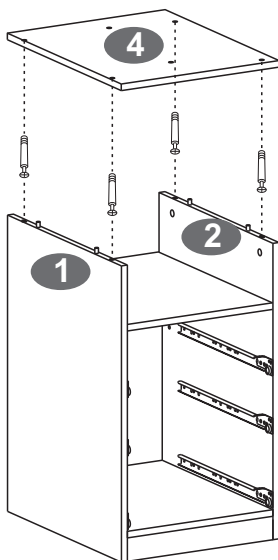

- Screw the Bolts (B) to the corresponding holes on the inside face of Top Panel (4), then assemble it to the cabinet by turning the corresponding cam locks.

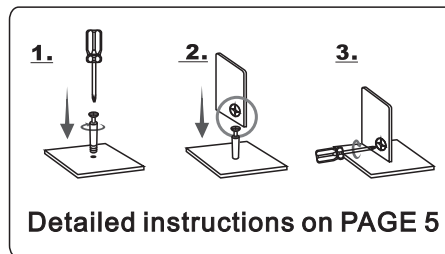

Detailed instructions on PAGE 5

▪ SCREWS

B 6X40 MM

4PCS



6

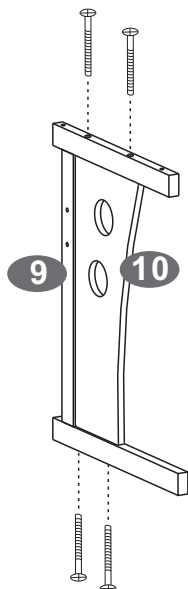

- Use Screws (C) to assemble the Right Panel (10) to the Side Structure (9). Please refer to PAGE 6 to troubleshoot this step.

▪ SCREWS

C 6X75 MM

4PCS



7

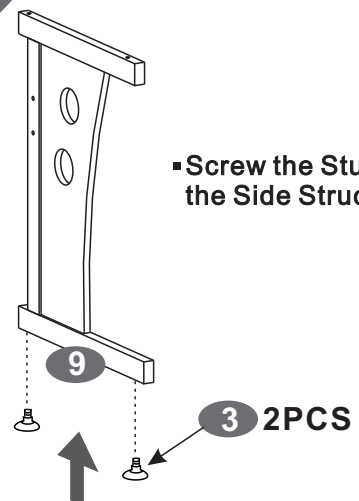

- Screw the Studs (3) to the Side Structure (9).

3 2PCS

8

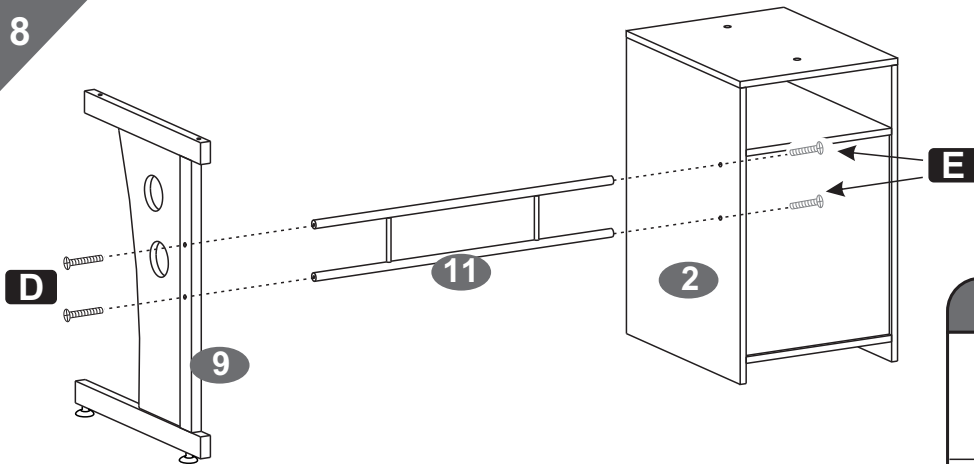

▪ Use Screws (D & E) to assemble the Back Structure (11) between the Middle Panel (2) and Side Structure (9).

▪ SCREWS

D 6X35 MM

2PCS

E 6X25 MM

2PCS

9

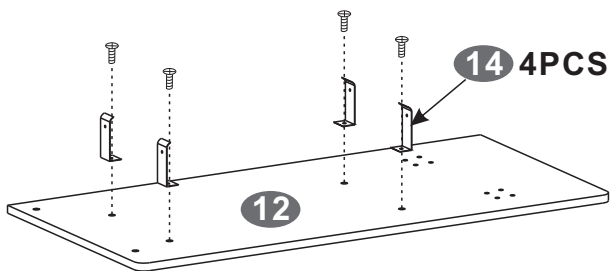

▪ Use Screws (F) to affix the Slider Bases (14) to the Main Panel (12).

▪ SCREWS

F 6X12 MM

4PCS

10

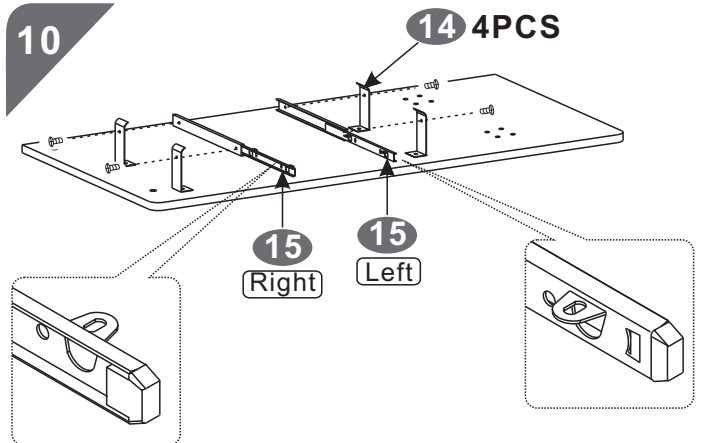

▪ Use Screws (G) to fix the Keyboard Slider (15) to the Slider Bases (14) as illustrated. Please note the position of the tabs on the sliders.

▪ SCREWS

G 4X4 MM

4PCS

11

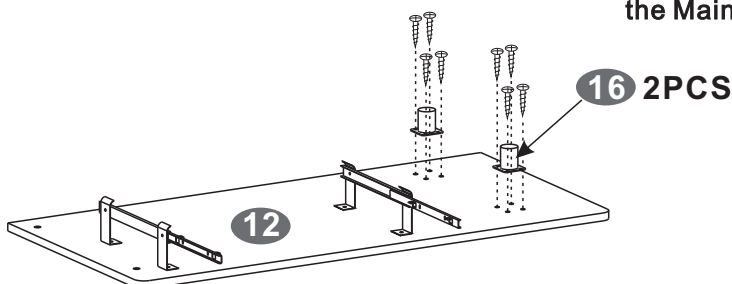

▪ Use Screws (H) to affix the Support Tubes (16) to the Main Panel (12).

▪ SCREWS

H 4X14 MM

8PCS

12

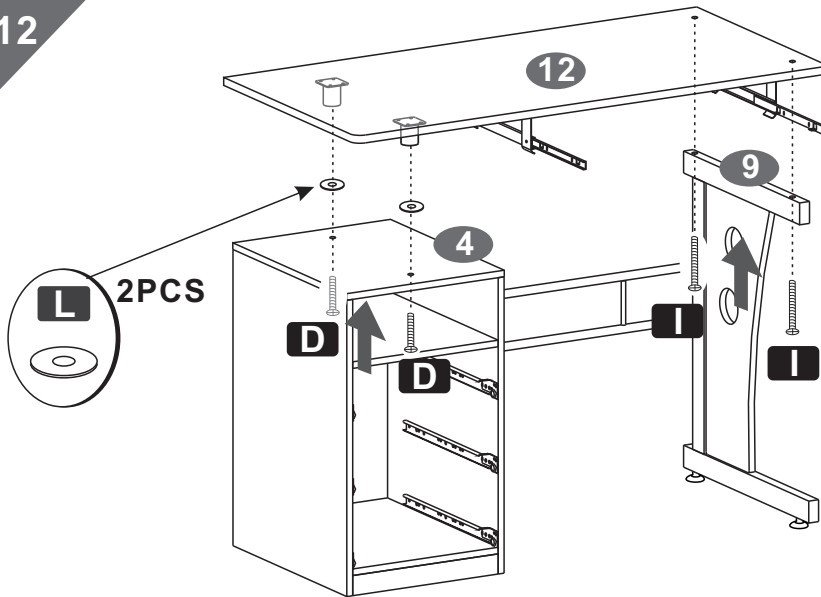

Place the plastic washer (L) in between the Top Panel (4) and Support Tubes (16), and assemble the Main Panel (12) using screws (D) on the LEFT and (I) on the RIGHT.

SCREWS

I 6X60 MM
2PCS

D 6X35 MM
2PCS

13

Use Screws (H) to assemble the Keyboard Panel (13) to the Keyboard Slider (15).

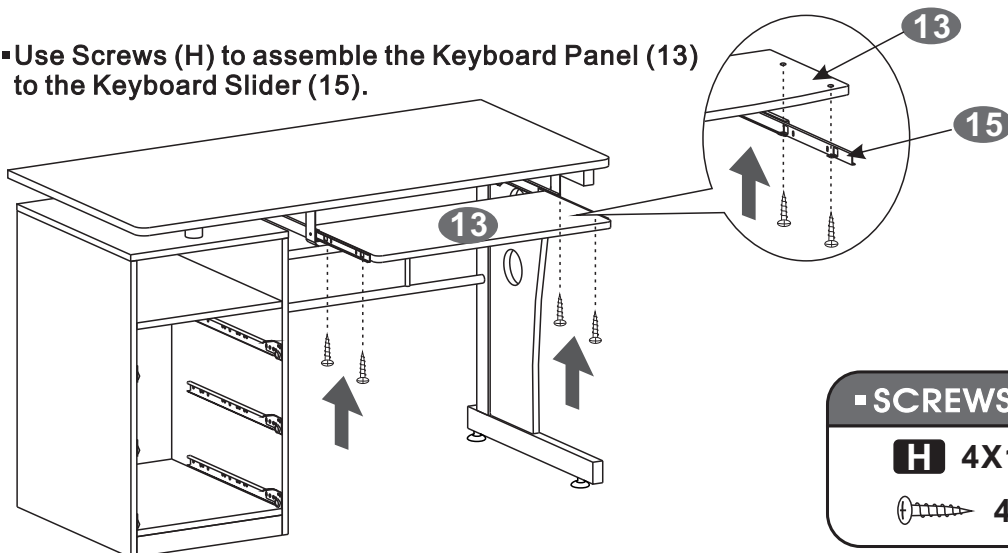

SCREWS

H 4X14 MM
4PCS

14

Screw Bolts (B) to the holes on the inside face of Drawer Front Panel (19), then assemble the Drawer Left & Right Panels (17 & 18) as shown by turning the cam locks.

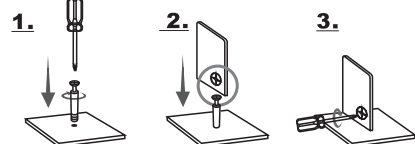
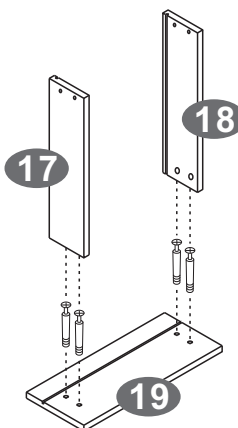

Detailed instructions on PAGE 5

SCREWS

B 6X40 MM
4PCS

15

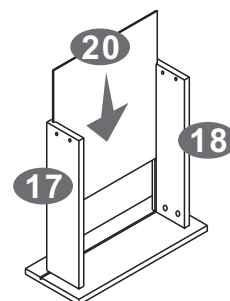

Slide in the Drawer Bottom Panel (20) thru the channels in between panels (17) & (18) as shown. Make sure the panel fits inside all the channels.

16

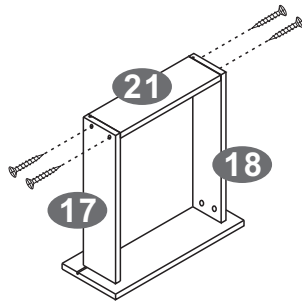

▪ Assemble the Drawer Back Panel (21) between the Drawer Left & Right Panels (17&18) using Screws (J) as shown.

▪ SCREWS

J 4X35 MM

4PCS



17

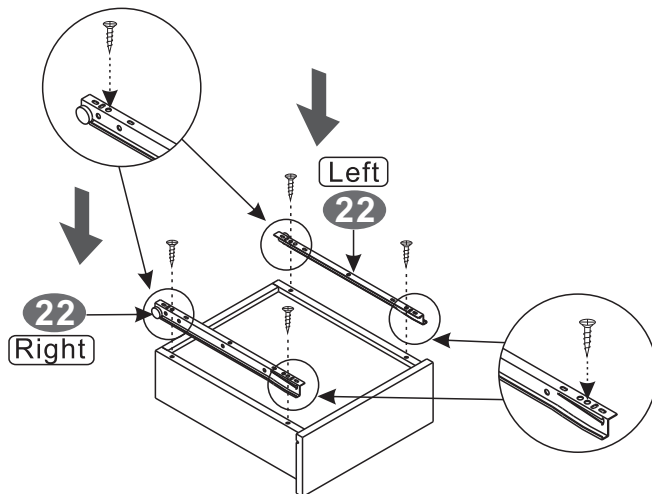

▪ Place the drawer upside-down. Grab the “L” shaped sliders (22) and assemble them to the drawer using Screws (A), with wheels facing towards the back of the drawer. Make sure the sliders are touching the side panels, and that they are not “up in the air”.

▪ SCREWS

A 3X15 MM

4PCS



18

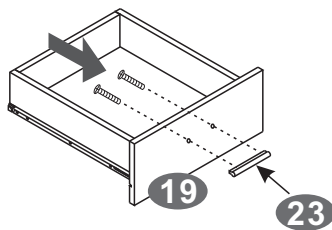

▪ Assemble the Handle (23) to the Drawer Front Panel (19) using Screws (K) as shown.

PLEASE REPEAT STEP 14 TO 19 FOR OTHER TWO DRAWERS

▪ SCREWS

K 4X20 MM

2PCS



19

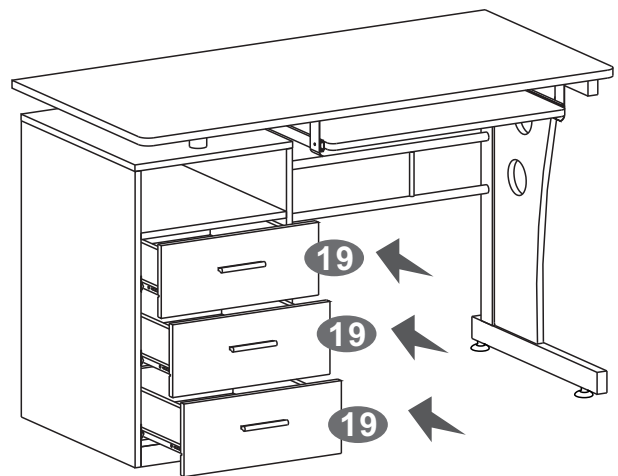

▪ Carefully insert all the drawers starting from the bottom. Make sure the wheels from the drawers engage and roll in the middle of the sliders.

CARE AND MAINTENANCE

English

- DO NOT EXPOSE THE SURFACES TO DIRECT SUNLIGHT, OR TO EXTREME ENVIRONMENTAL CONDITIONS. EXPOSURE WILL DAMAGE THE PRODUCT, WHICH IS NOT COVERED BY THE WARRANTY.
- CLEAN THE SURFACES PREFERABLE WITH A SOLUTION OF A SMOOTH SOAP AND WATER, THEN CLEAR WITH A DRY TOWEL.
DO NOT USE SOLVENTS OVER STRUCTURAL TUBES.
- BEFORE MOVING OR TRANSPORTING THE UNIT:
 - *REMOVE ALL OBJECTS FROM THE TABLETOP, SHELVES, DRAWERS OR COMPARTMENTS THAT ARE HEAVY OR MIGHT FALL OFF.
 - *THE UNIT MUST BE HANDLED BY AT LEAST 2 PERSONS.
 - *WHEN LIFTING, USE BOTH HANDS AND BEND YOUR LEGS (NOT YOUR BACK).
 - *IF THE UNIT IS ON CASTERS (WHEELS), MAKE SURE THAT THEY ARE UNLOCKED.
- DO NOT LEAN OVER THE TABLE OR SEAT ON IT.
- DO NOT ALLOW CHILDREN TO PLAY OVER OR UNDER THE TABLE.
- IN CASE OF GLASS BREAKAGE (ITEMS WITH GLASS TABLE TOPS OR GLASS PARTS), DO NOT HANDLE THE BROKEN GLASS WITH YOUR BARE HANDS, AND NOTIFY THE VENDOR IMMEDIATELY.