

English

ASSEMBLY INSTRUCTIONS

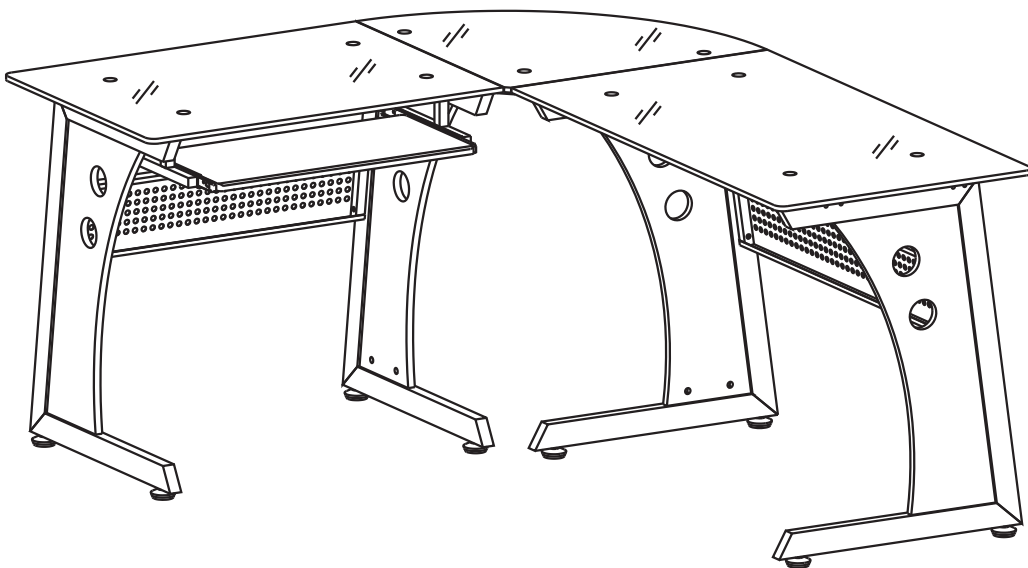

Thanks for purchasing one of our products.
Please read carefully the assembly instructions before the installation.
Please save this manual for future reference.



MODEL RTA-3803



RTA-3803

DIMENSIONS

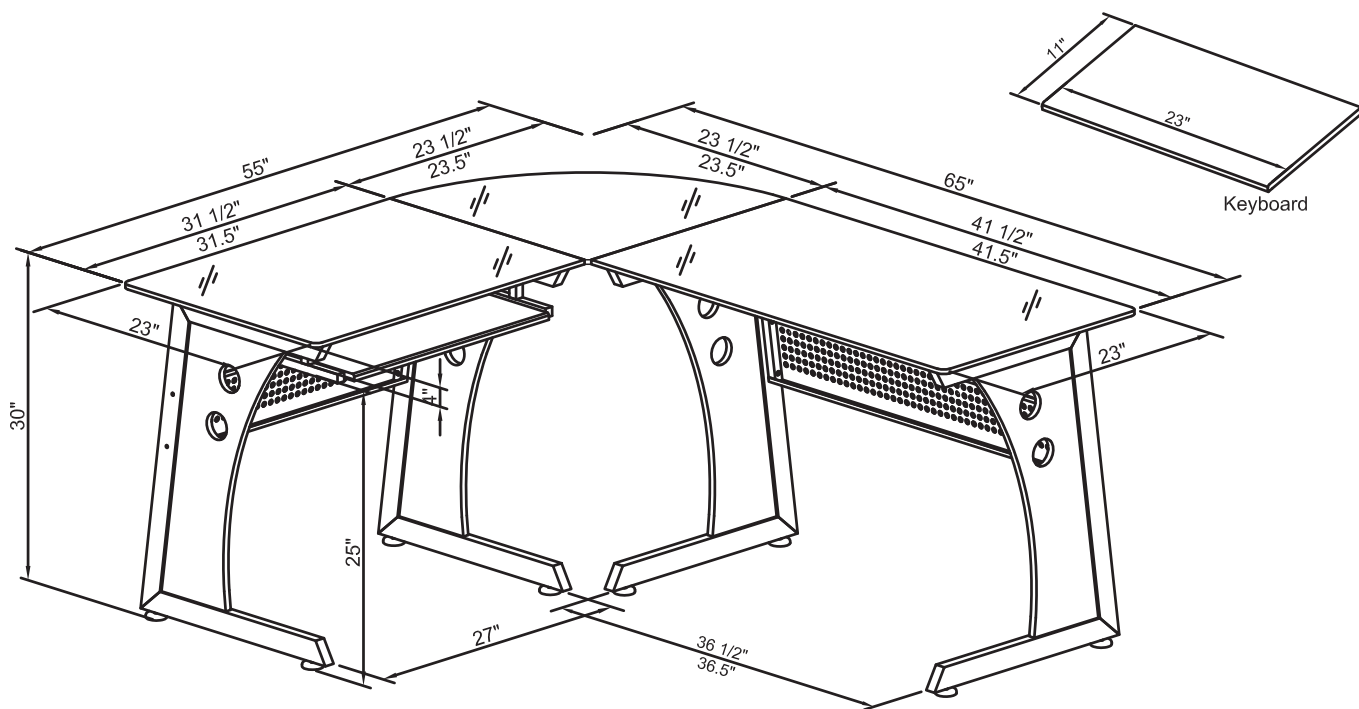

Product Size: 55"W x 65"D x 30"H

MAXIMUM WEIGHT CAPACITIES

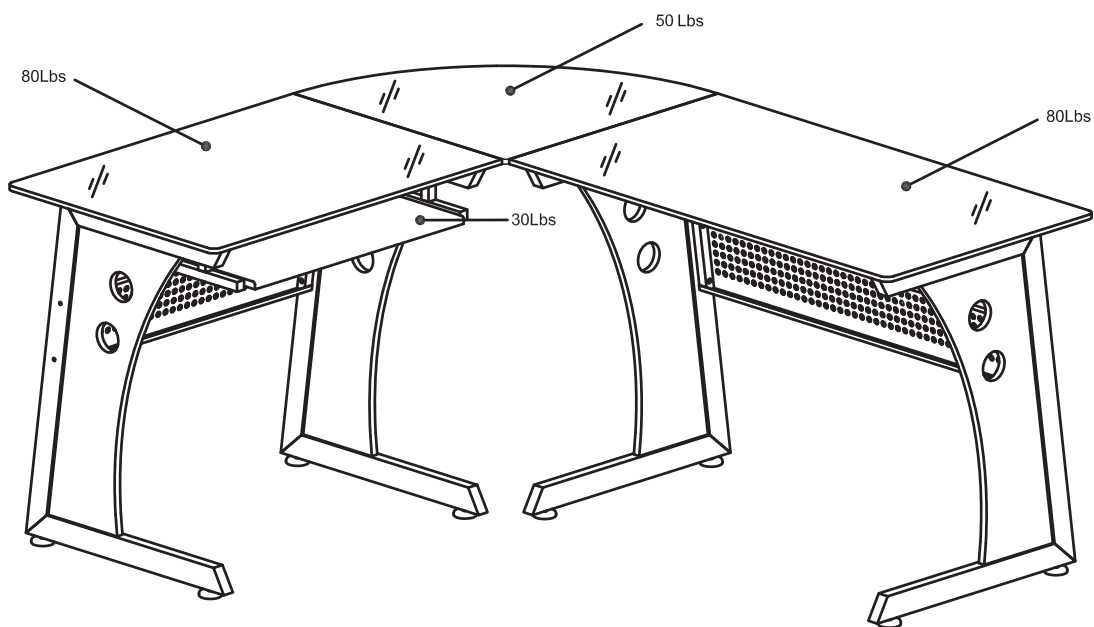





DO NOT exceed this limit
Please use care and good judgement
when placing objects on wood surface

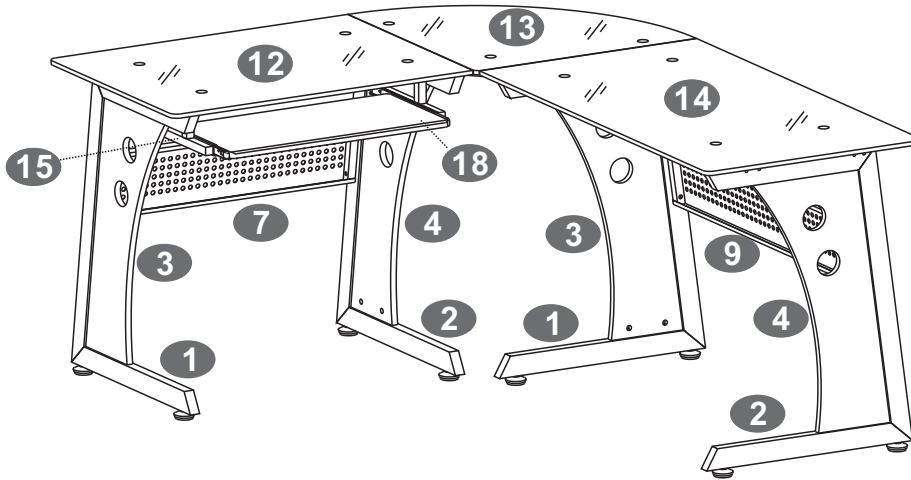

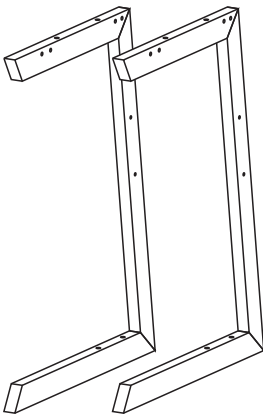
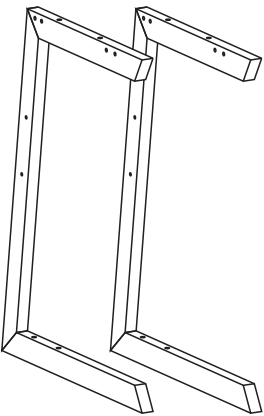
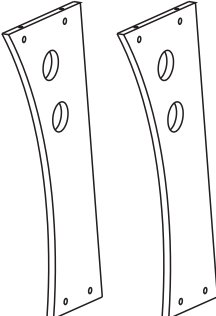
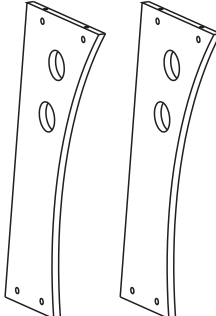
■PARTS LIST

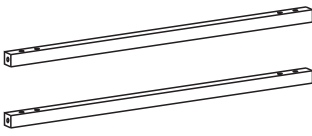
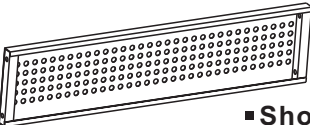
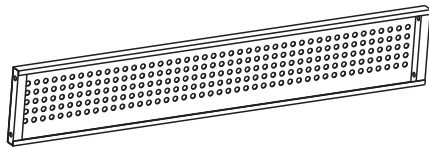

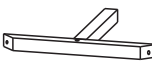
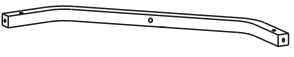
<p>1</p>  <p>■Left Structure x 2</p>	<p>2</p>  <p>■Right Structure x 2</p>	<p>3</p>  <p>■Left Panel x 2</p>	<p>4</p>  <p>■Right Panel x 2</p>
<p>5</p>  <p>■Studs x 8</p>	<p>6</p>  <p>■Short Horizontal Tube x 2</p>	<p>7</p>  <p>■Short Back Panel</p>	
<p>9</p>  <p>■Long Back Panel</p>		<p>8</p>  <p>■Long Horizontal Tube x 2</p>	
		<p>10</p>  <p>■T Structure</p>	<p>11</p>  <p>■Connecting Tube</p>

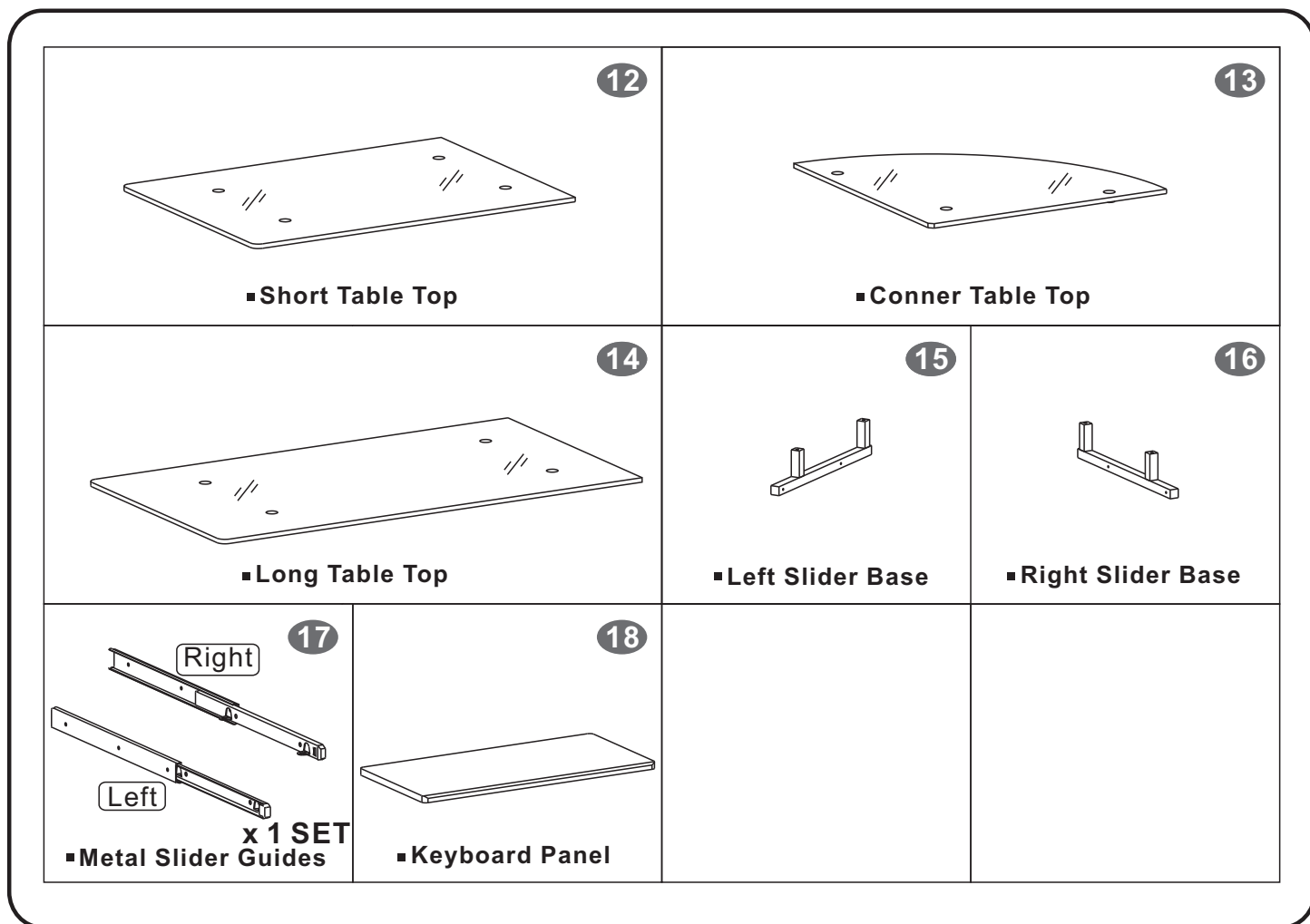

▪SCREWS LIST

PART	QTY.	ITEM	
A	16	6X75 MM	
B	13	6X35 MM	
C	11	6X30 MM	
D	4	4X10 MM	

PART	QTY.	ITEM	
E	4	4X14 MM	
F	12	6X40 MM	
	1		

ASSEMBLY TIPS ARE LOCATED AT THE END OF THE MANUAL.

ATTENTION: HOLES ON PANELS MAY BE HIDDEN UNDERNEATH PVC LAMINATE!!!
DO NOT TIGHTEN THE SCREWS UNTILL ALL OF THEM ARE IN THE RIGHT POSITION.

▪ ASSEMBLY STEPS:

1

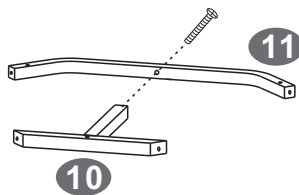

- Use Screws (B) to assemble the “T” Structure (10) to the Connecting Tube (11).

▪ SCREWS

B 6X35 MM

1PC



2

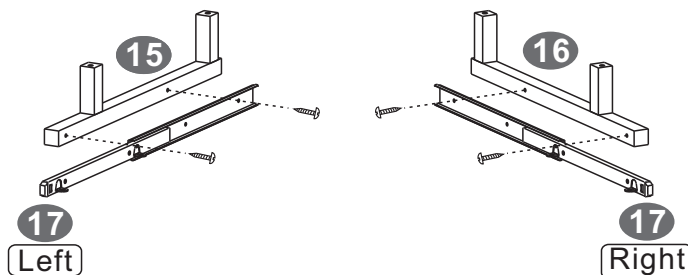

- Use Screws (D) to assemble the Metal Slider Guides (17) to the Left & Right Slider Bases (15&16).

▪ SCREWS

D 4X10 MM

4PCS



3

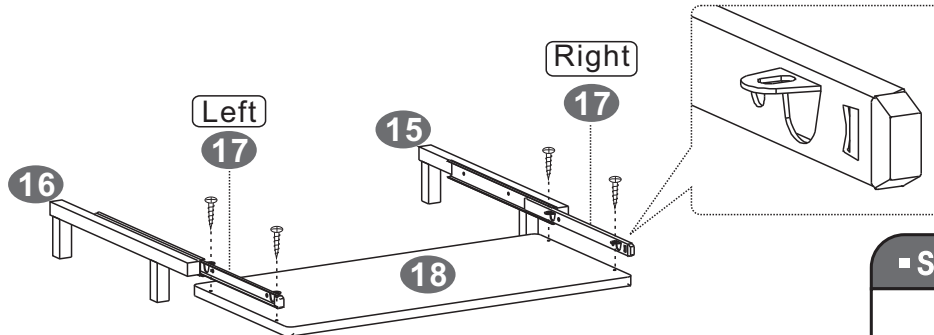

■ Use Screws (E) to assemble the Keyboard Panel (18) to the Metal Slider Guides (17) as shown.

■ SCREWS

E 4X14 MM

4PCS

4

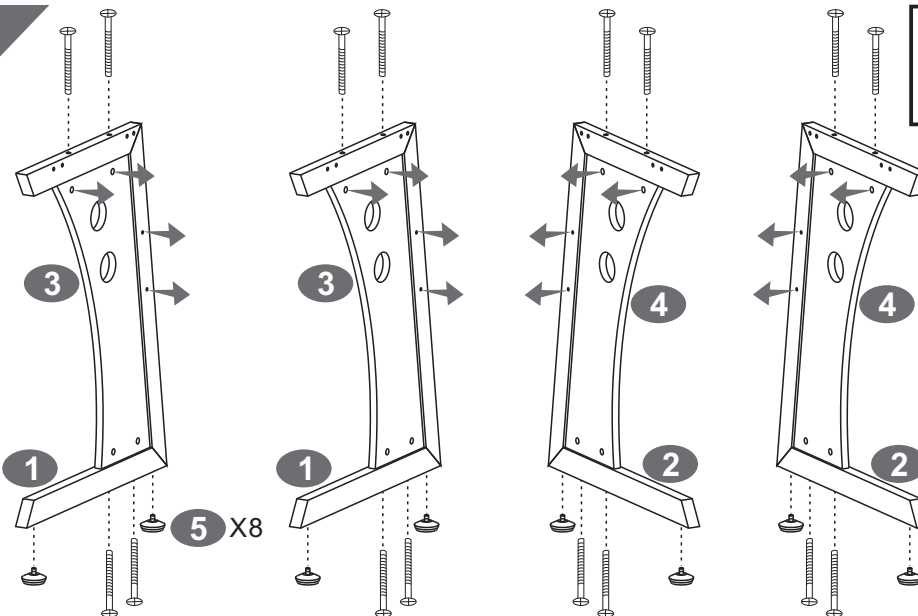

Please refer to the Assembly Tips at the end of the manual for troubleshooting this step.

■ Use Screws (A) to assemble the Left & Right Panels (3&4) to the Left & Right Structures (1&2). Please pay attention to the direction of the holes on the panels and structures!!! Then attach the Studs (5) to the bottom of the structures.

■ SCREWS

A 6X75 MM

16PCS

5

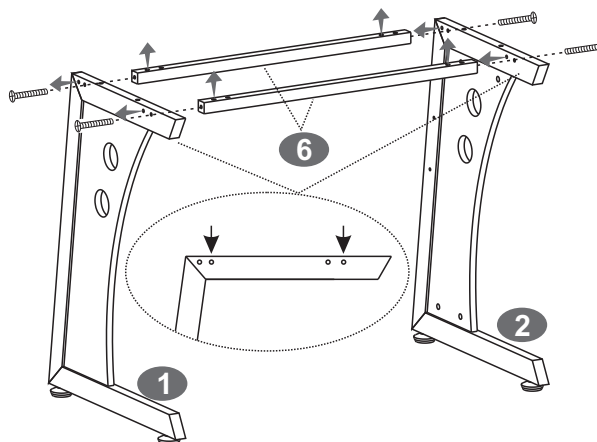

■ Use Screws (F) to assemble the Short Horizontal Tubes (6) between the Left & Right Structure (1&2). Please pay attention to the holes being used on the structures!!! Please pay attention to the direction of the holes on the tubes!!!

■ SCREWS

F 6X40 MM

4PCS

6

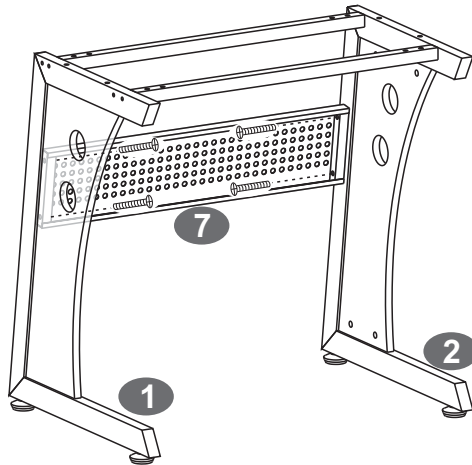

- Use Screws (B) to assemble the Short Back Panel (7) between the Left & Right Structure (1&2).

▪ SCREWS

B 6X35 MM

 4PCS



7

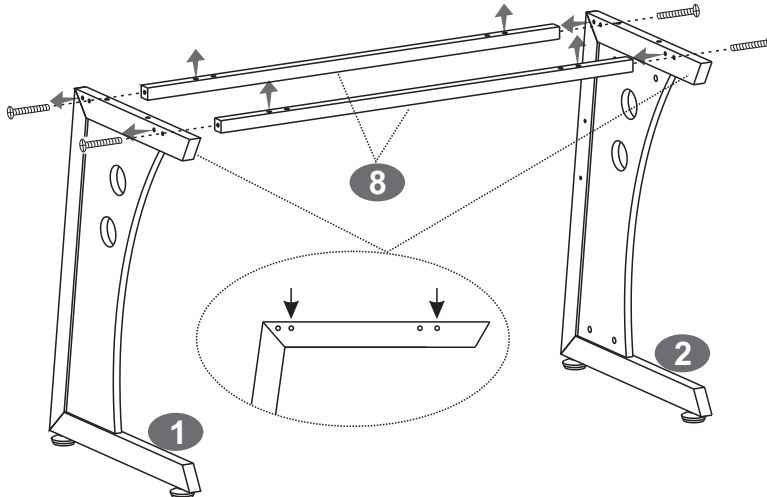

- Use Screws (F) to assemble the Long Horizontal Tubes (8) between the Left & Right Structure (1&2).
Please pay attention to the holes being used on the structures!!!
Please pay attention to the direction of the holes on the tubes!!!

▪ SCREWS

F 6X40 MM

 4PCS



8

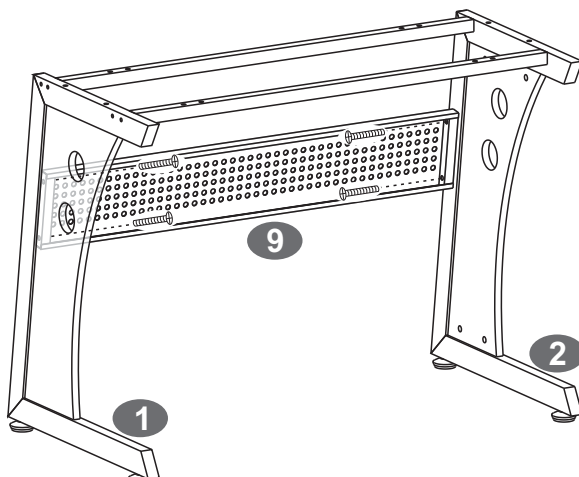

- Use Screws (B) to assemble the Long Back Panel (9) between the Left & Right Structure (1&2).

▪ SCREWS

B 6X35 MM

 4PCS



**** There are 4 options in which to assemble this L-desk. Please select below according to your preference:**

- A**
A1-A4 Left short table with keyboard panel+ Right long table

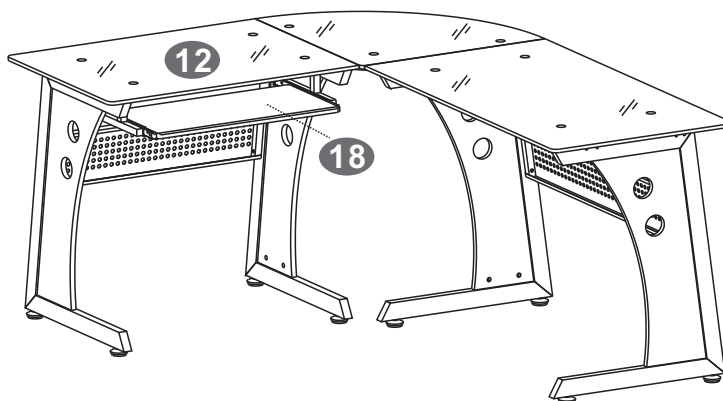

- B**
B1-B4 Left short table + Right long table with keyboard panel

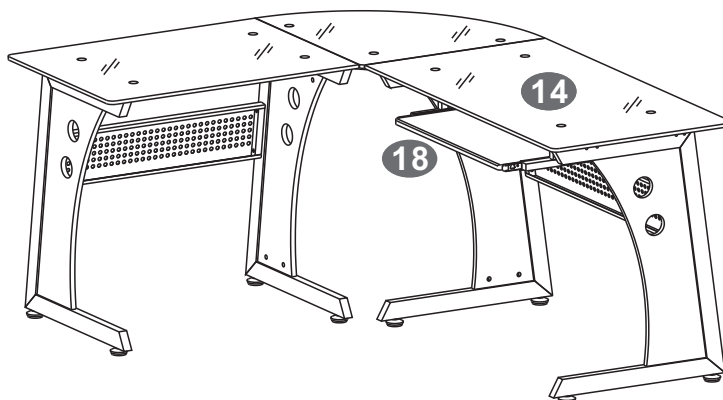

- C**
C1-C4 Left long table with keyboard panel+ Right short table

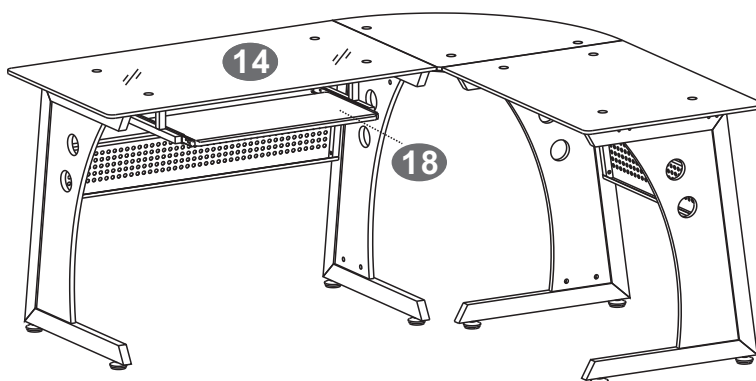

- D**
D1-D4 Left long table + Right short table with keyboard panel

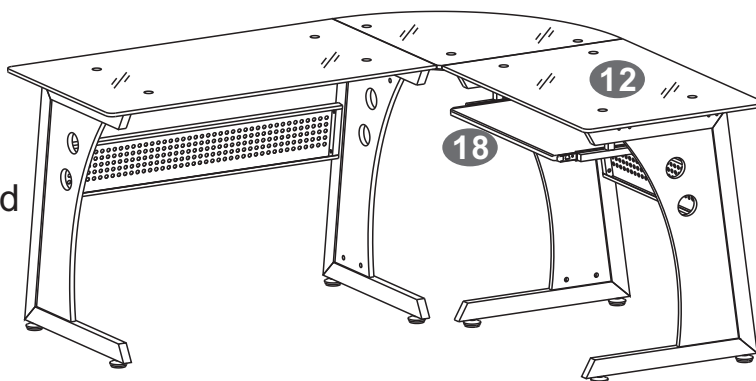

A1

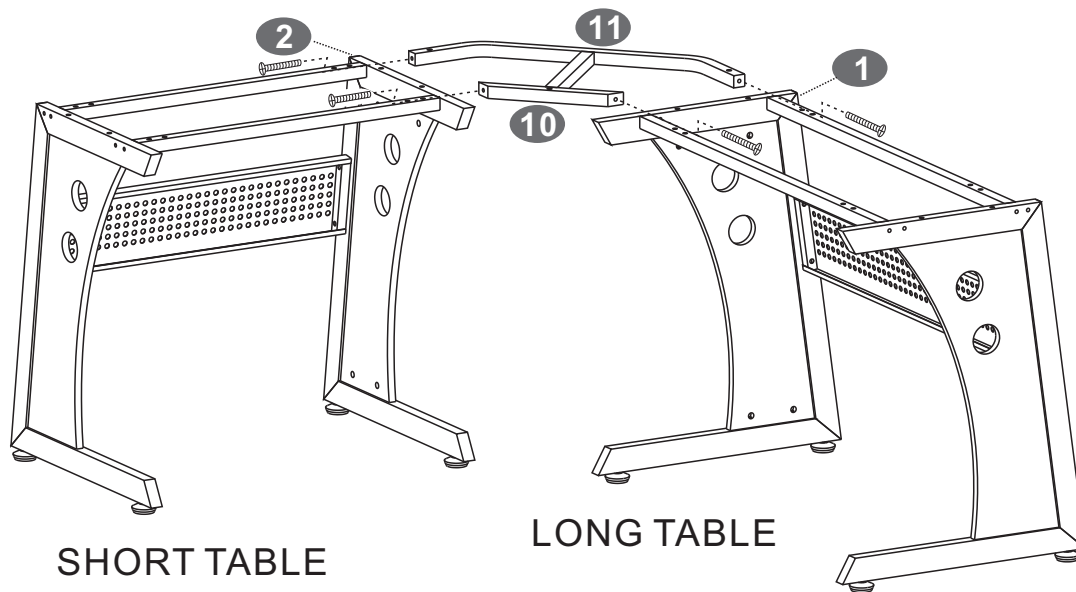

- Use Screws (F) to fix the “T” Structure (10) and the Connecting Tube (11) to the Right Structure (2) and the Left Structure (1).

■ SCREWS

F 6X40 MM

4PCS



A2

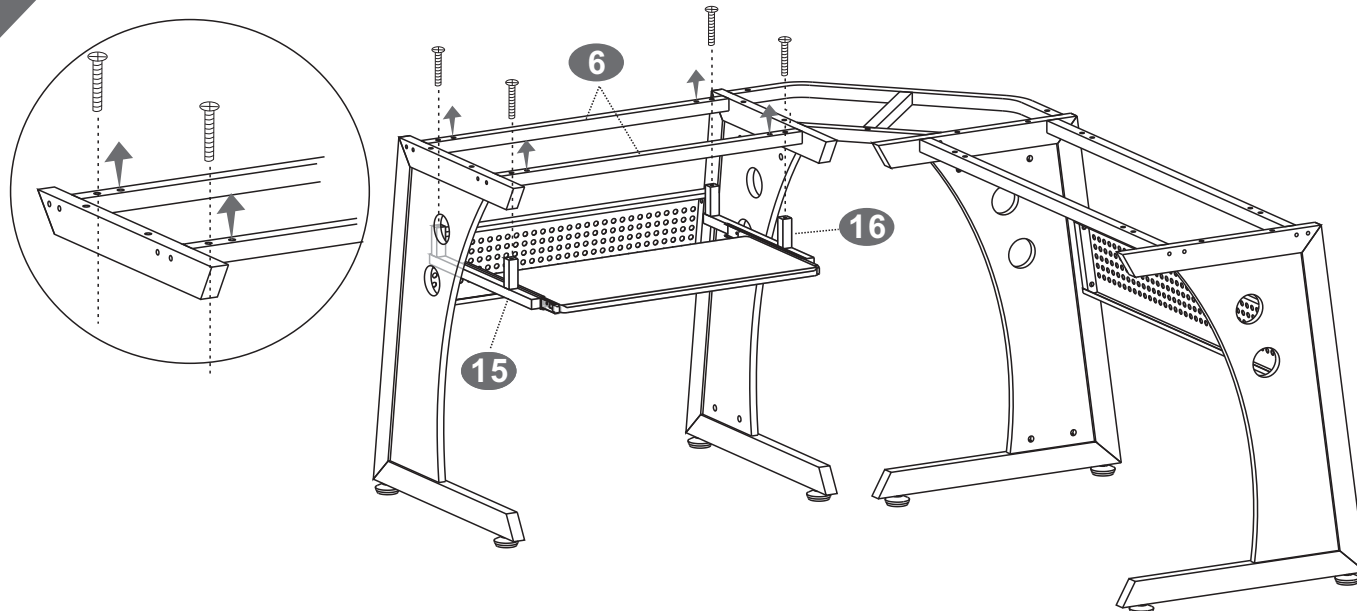

- Use Screws (B) to assemble the Left & Right Slider Base (15&16) to the Short Horizontal Tubes (6).
Please pay attention to the holes being used on the tubes!!!

■ SCREWS

B 6X35 MM

4PCS



A3

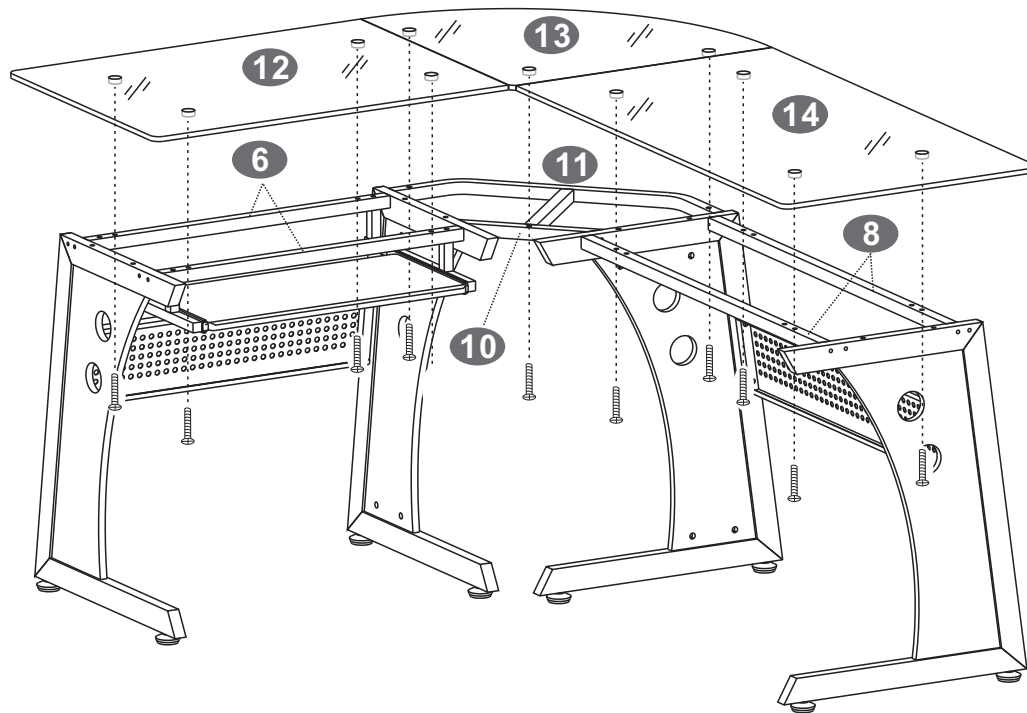

- Use Screws (C) to assemble the Short Table Top (12), the Corner Table Top (13) and the Long Table Top (14).

■ SCREWS

C 6X30 MM

 11PCS

A4

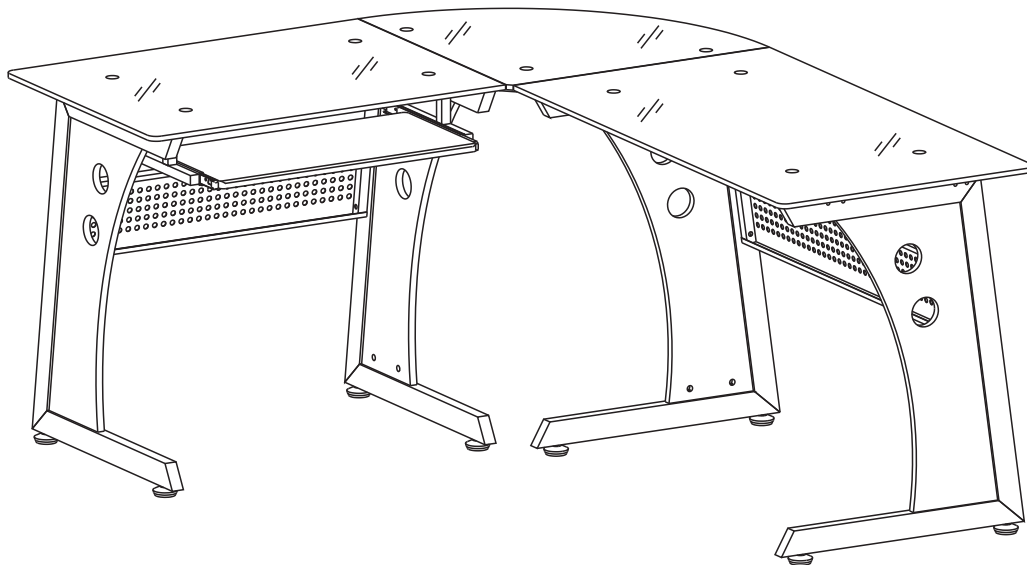

- Tighten all the screws and enjoy your unit.

B1

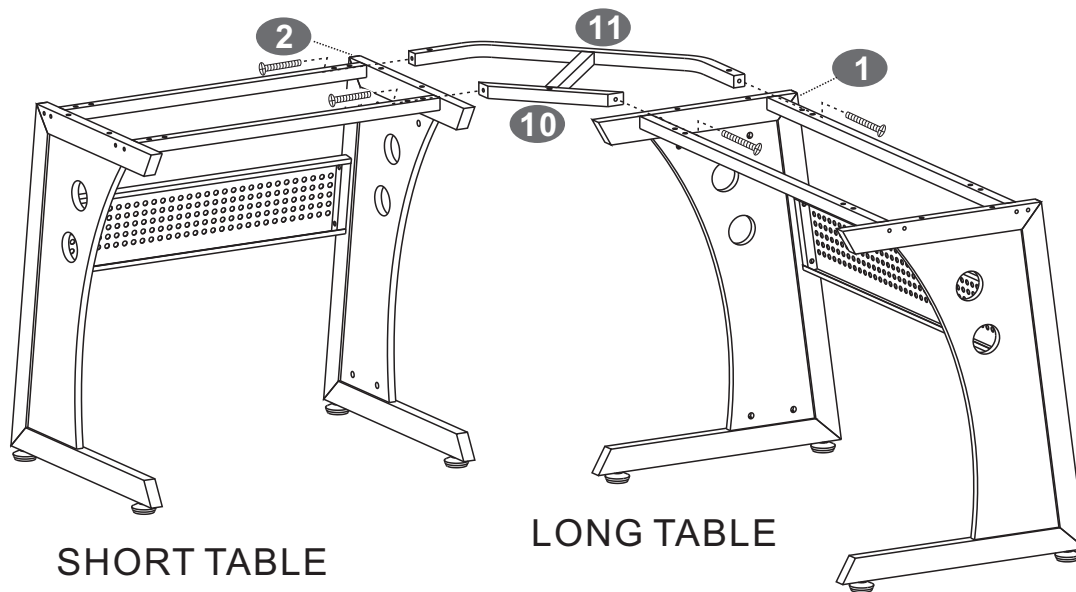

- Use Screws (F) to fix the “T” Structure (10) and the Connecting Tube (11) to the Right Structure (2) and the Left Structure (1).

■ SCREWS

F 6X40 MM

4PCS



B2

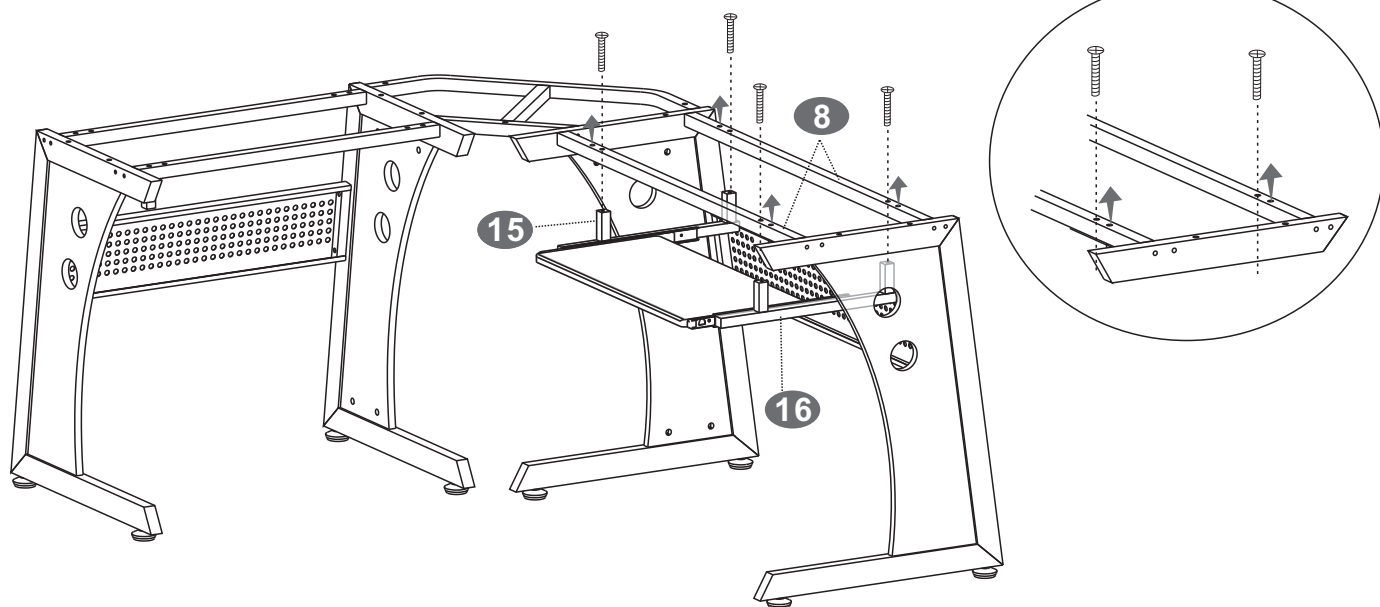

- Use Screws (B) to assemble the Left & Right Slider Base (15&16) to the Long Horizontal Tubes (8).
Please pay attention to the holes being used on the tubes!!!

■ SCREWS

B 6X35 MM

4PCS



B3

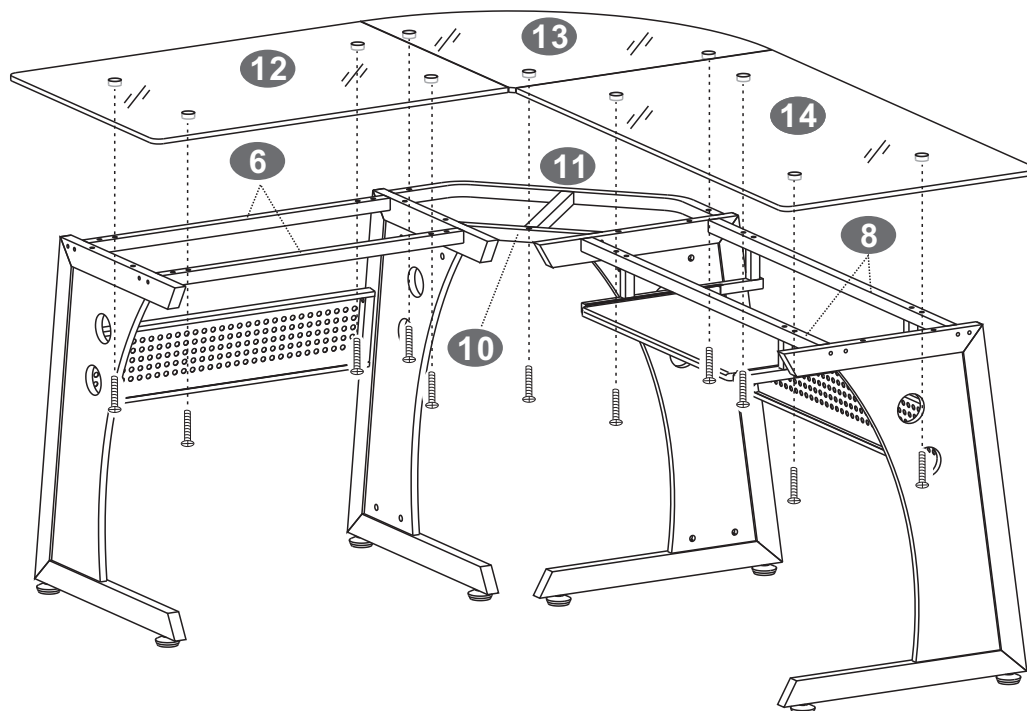

- Use Screws (C) to assemble the Short Table Top (12), the Corner Table Top (13) and the Long Table Top (14).

■ SCREWS

C 6X30 MM

 11PCS

B4

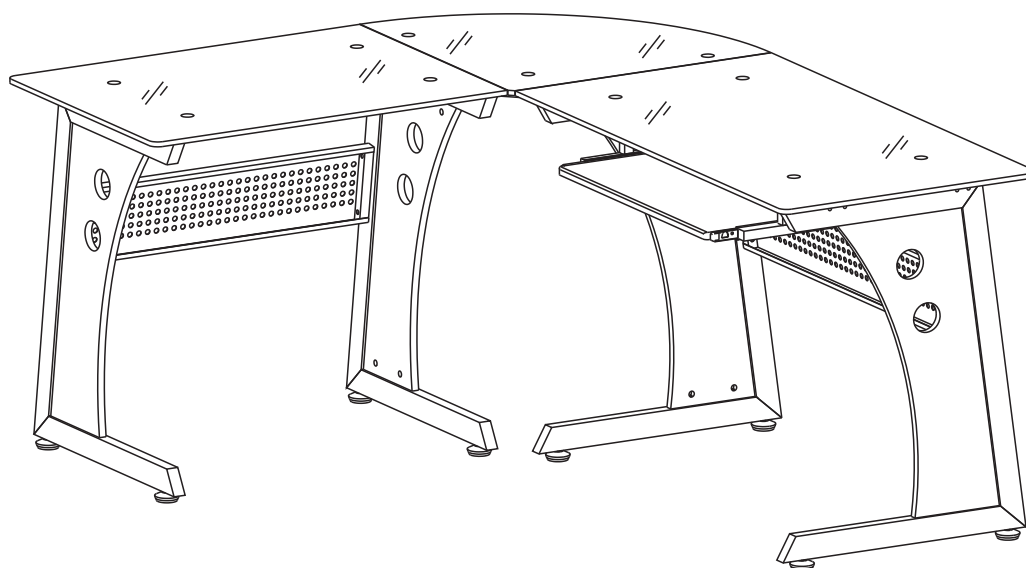

- Tighten all the screws and enjoy your unit.

C1

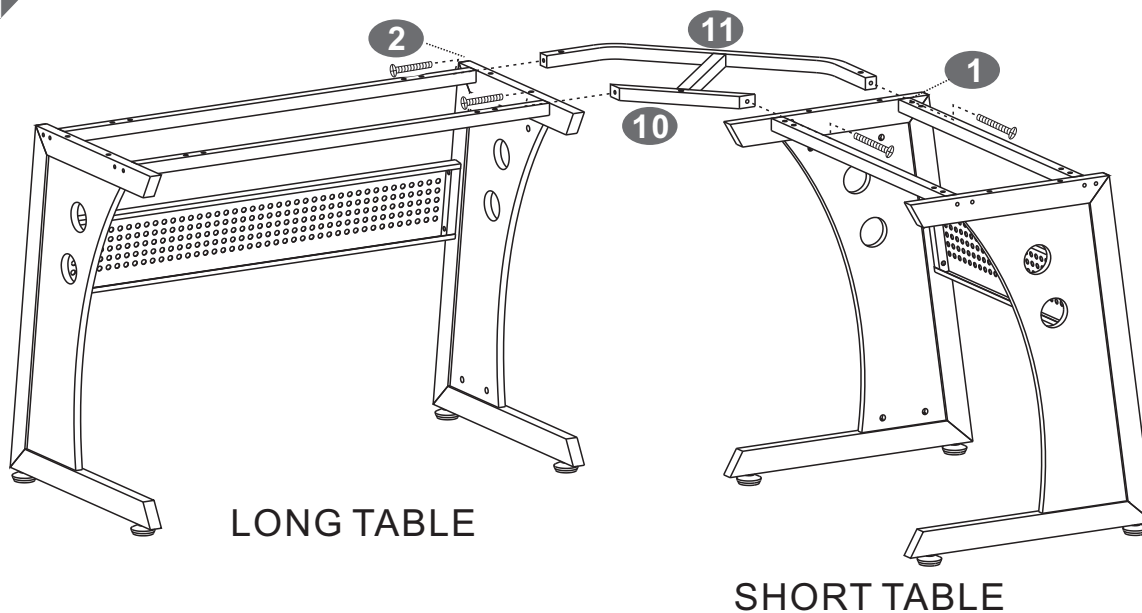

- Use Screws (F) to fix the “T” Structure (10) and the Connecting Tube (11) to the Right Structure (2) and the Left Structure (1).

-SCREWS

F 6X40 MM

4PCS



C2

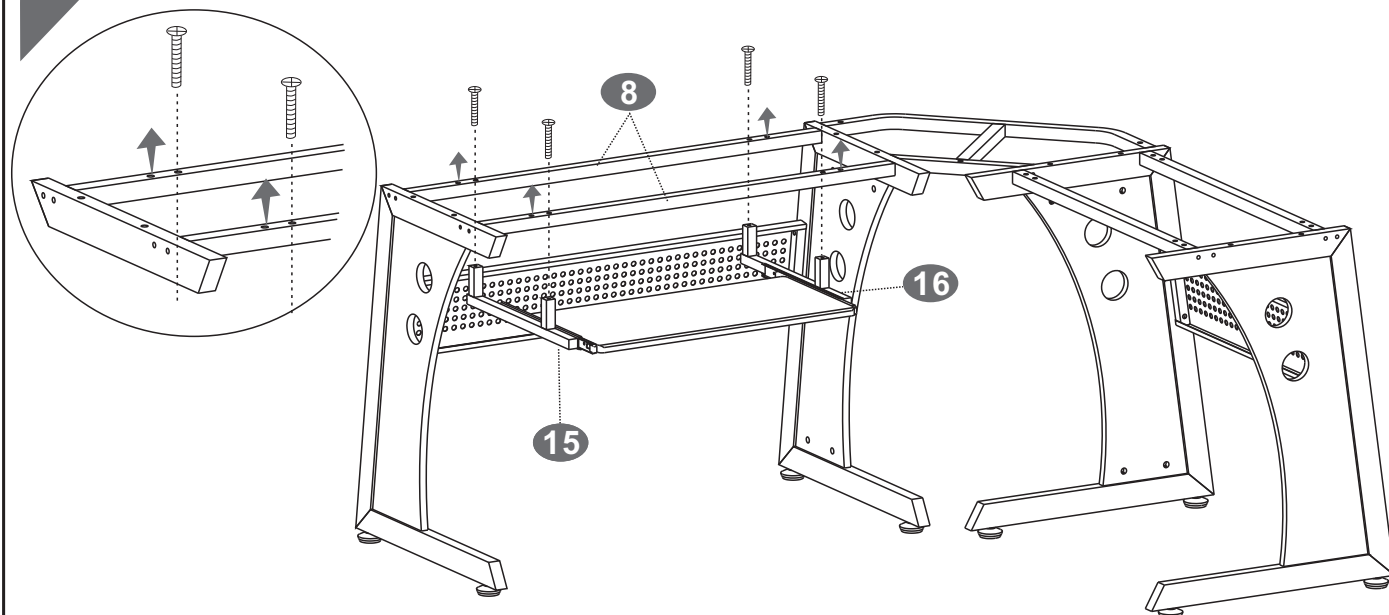

- Use Screws (B) to assemble the Left & Right Slider Base (15&16) to the Long Horizontal Tubes (8).
Please pay attention to the holes being used on the tubes!!!

-SCREWS

B 6X35 MM

4PCS



C3

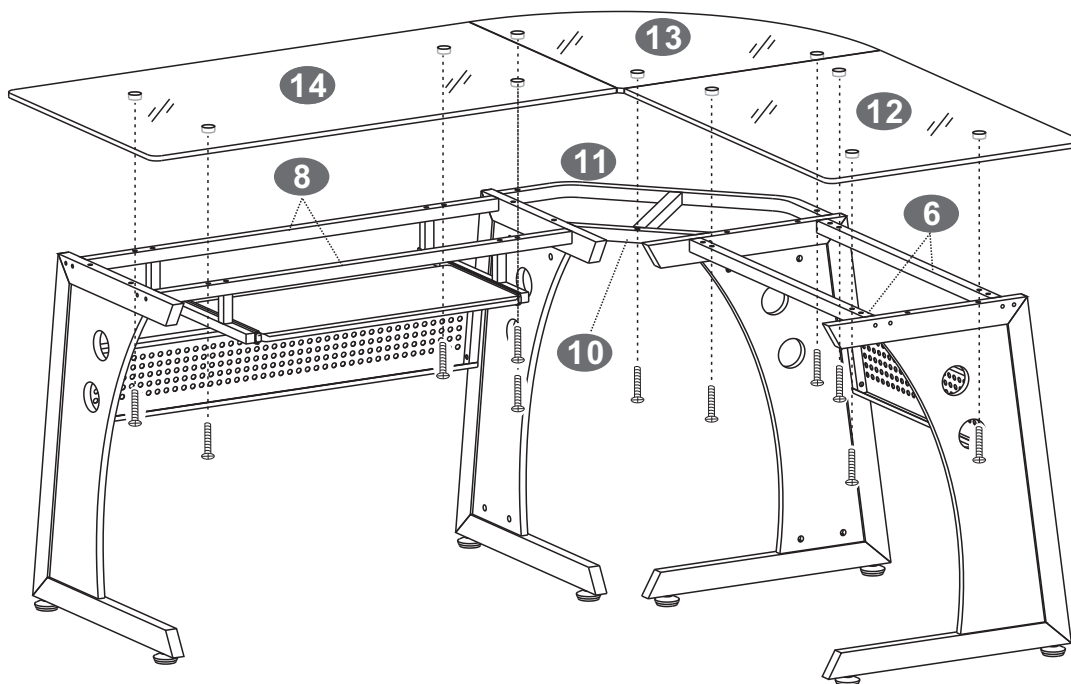

- Use Screws (C) to assemble the Short Table Top (12), the Corner Table Top (13) and the Long Table Top (14).

■ SCREWS

C 6X30 MM

11PCS



C4

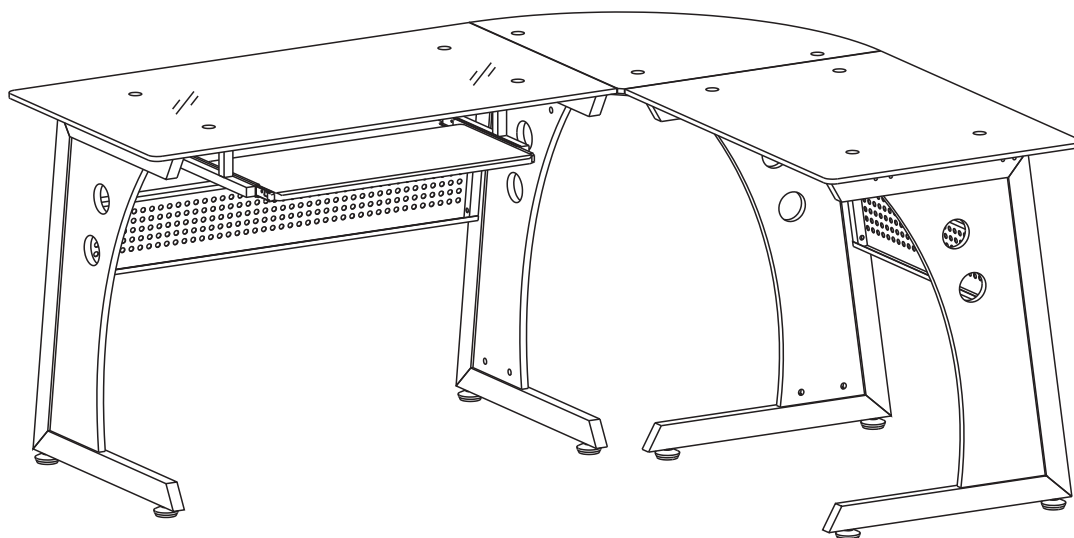

- Tighten all the screws and enjoy your unit.

D1

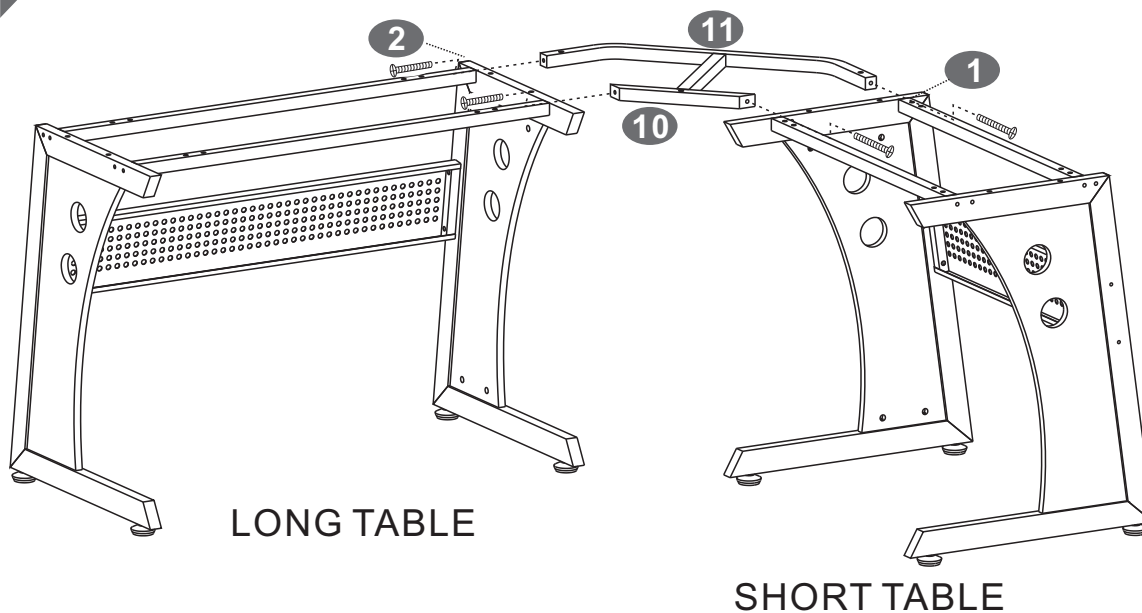

LONG TABLE

SHORT TABLE

- Use Screws (F) to fix the "T" Structure (10) and the Connecting Tube (11) to the Right Structure (2) and the Left Structure (1).

-SCREWS

F 6X40 MM

4PCS



D2

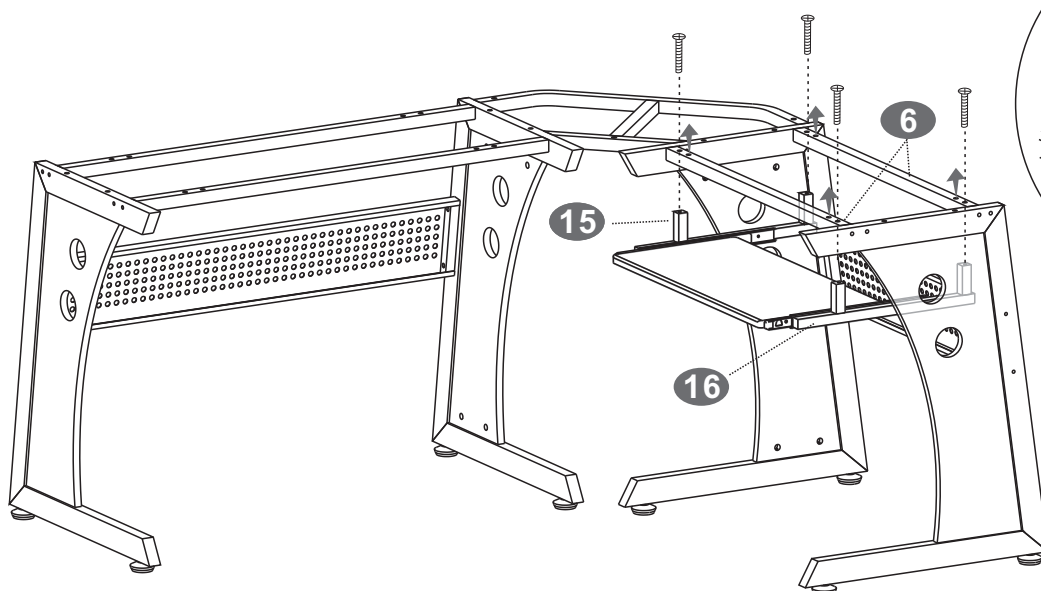

- Use Screws (B) to assemble the Left & Right Slider Base (15&16) to the Short Horizontal Tubes (6).
Please pay attention to the holes being used on the tubes!!!

-SCREWS

B 6X35 MM

4PCS



D3

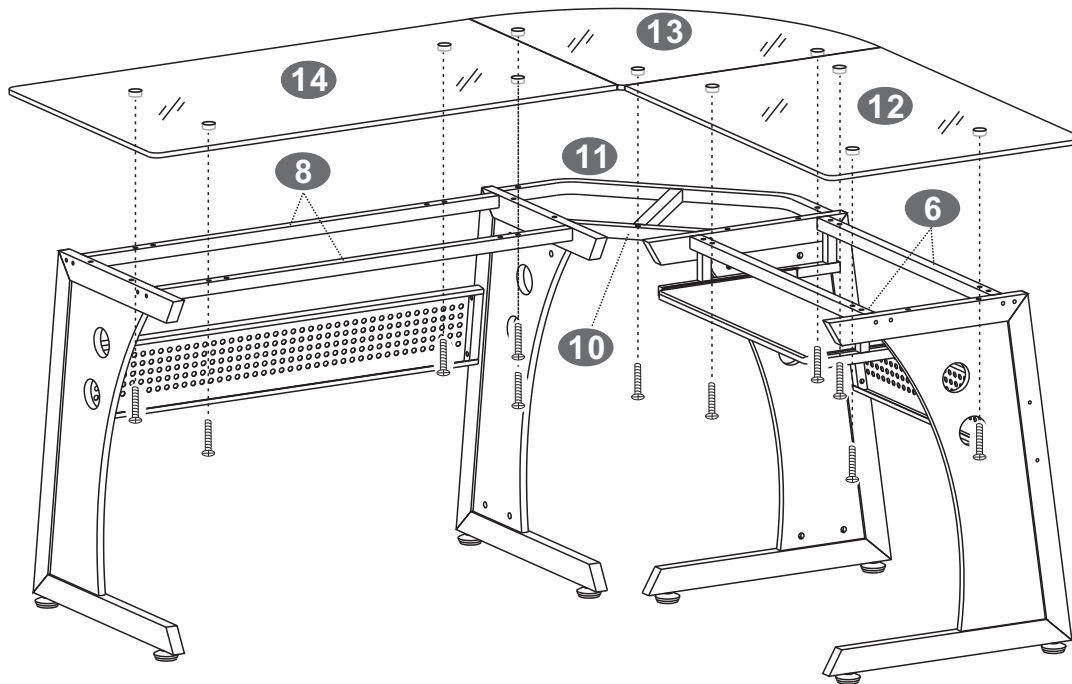

■ Use Screws (C) to assemble the Short Table Top (12), the Corner Table Top (13) and the Long Table Top (14).

■ SCREWS

C 6X30 MM

11PCS



D4

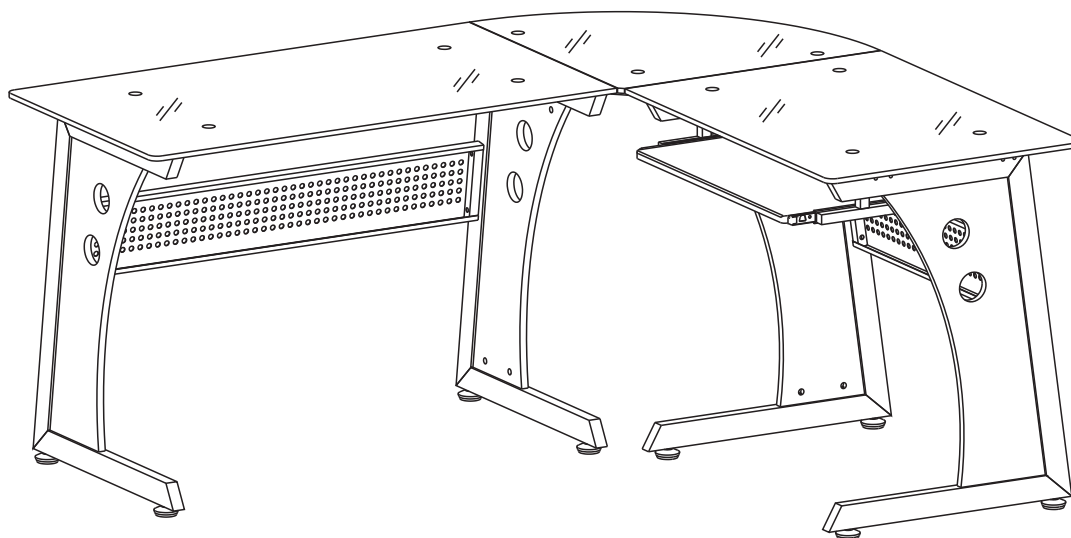

■ Tighten all the screws and enjoy your unit.

HELPFULL ASSEMBLY TIPS

- MAKE SURE THE PACKAGE CONTAINS ALL THE PARTS LISTED IN THE LIST OF PARTS, INCLUDING ANY HARDWARE.

PART NO.	DESCRIPTION	QTY
1	FRAME	2 ✓
2	SUPPORT	2 ✓
3	BACK PANEL	1
4	GLIDE	4
5	TABLETOP	1
A	6x20mm SCREW	4
B	6x30mm SCREW	8
C	TOOL	1

- FOLLOW THE ASSEMBLY INSTRUCTIONS STEP BY STEP, AND DO NOT SKIP ANY, UNLESS ADVISED TO DO SO BY AN RTA PRODUCT'S TECHNICIAN.

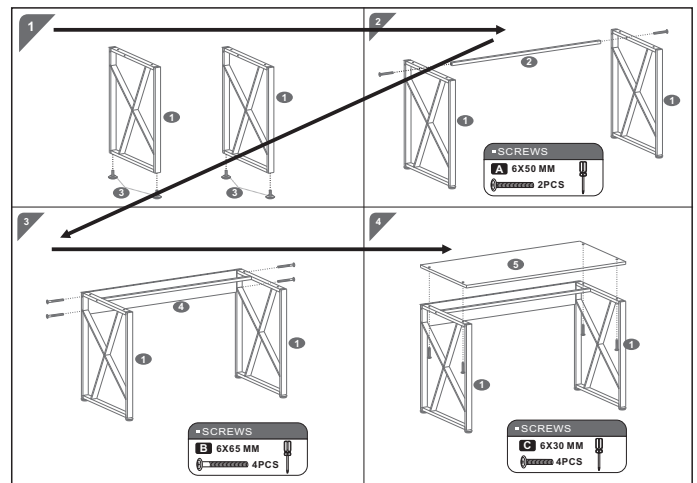

- ON EACH STEP, AND TO AVOID MISALIGNMENTS, ALWAYS LEAVE SCREWS LOOSE, AND DO NOT TIGHTEN THEM UNTIL ALL ARE IN PLACE.

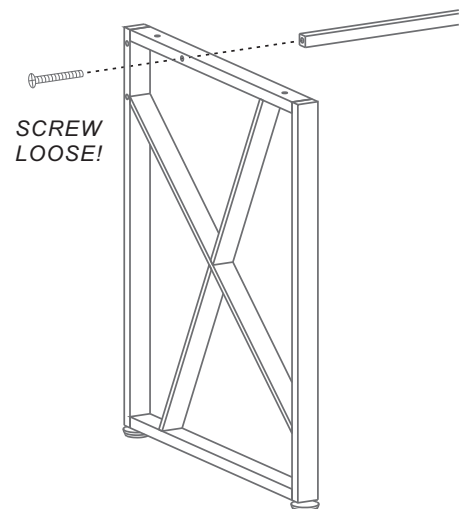

- MAKE SURE TO USE THE CORRECT SCREWS OR BOLTS AND DO NOT OVERTIGHT THEM. DOING SO MIGHT CAUSE DAMAGE TO THE PARTS OR PRODUCTS WHICH IS NOT COVERED BY THE PRODUCT'S WARRANTY.



CORRECT SIZE OF SCREW.

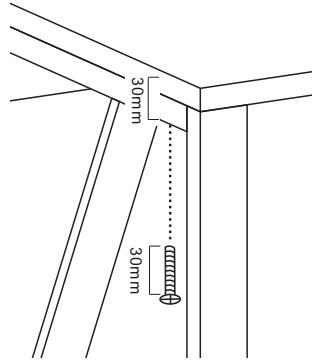

SCREW WILL DAMAGE THE PART!

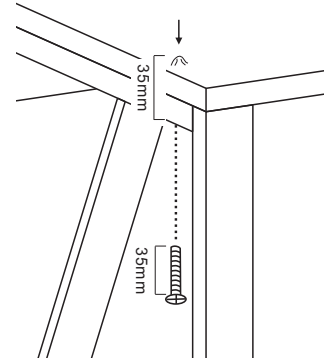

- IN SOME WOOD PANELS THE LAMINATE MIGHT BE COVERING THE HOLES. LOOK FOR INDENTATIONS IN THE AREA WHERE THE HOLE SHOULD BE. IF THE HOLES LOOK TOO SMALL FOR A SCREW, JUST CAREFULLY PUSH THE SCREW THRU THEM.

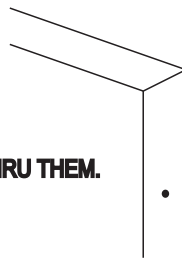

DOES THE HOLE LOOK TOO SMALL?

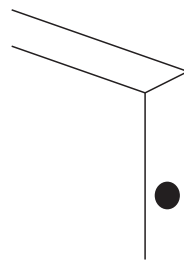

THE HOLE IS BIGGER THAN WHAT IT APPEARED.

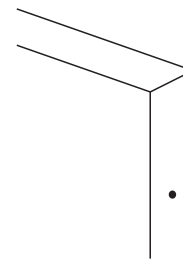

CAREFULLY PERFORATE.

- SOME WOOD PANELS HAVE METAL INSERTS THAT LOOK LIKE SCREWS. THESE PARTS ARE EITHER NUTS OR CAM LOCKS. MAKE SURE THEY ARE ALIGNED TO RECEIVE THE SCREWS OR BOLTS.

MISALIGNED NUT:

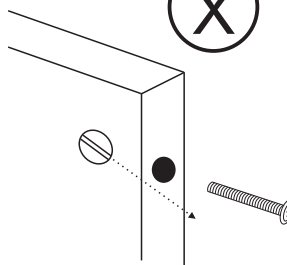

ALIGNED NUT:

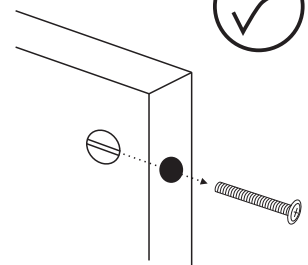

MISALIGNED CAM LOCK:

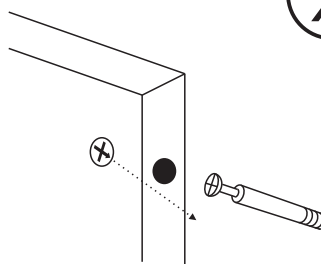

ALIGNED CAM LOCK:

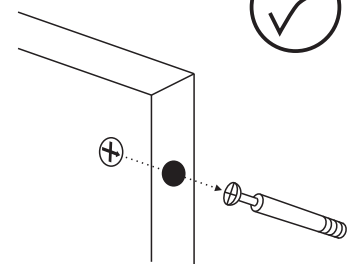

CARE AND MAINTENANCE

English

- DO NOT EXPOSE THE SURFACES TO DIRECT SUNLIGHT, OR EXTREME ENVIRONMENTAL CONDITIONS. EXPOSURE WILL DAMAGE THE PRODUCT, WHICH IS NOT COVERED BY THE WARRANTY.
- DO NOT USE SOLVENTS OVER SURFACES OR STRUCTURAL TUBES. SURFACES MUST BE CLEANED WITH A SOLUTION OF A SMOOTH SOAP AND WATER, THEN CLEARED WITH A DRY TOWEL.
- PRODUCTS THAT ARE HEAVY SHOULD BE LIFTED OR MOVED BY AT LEAST 2 PERSONS, AND ALL OBJECTS SHOULD BE REMOVED FROM THE PRODUCT.