

Guard Mounted Direct Drive Exhaust Fans

Features

- Bolts directly to the wall
- Can be used with or without external shutter
- Pull chain switch
- No Cord-Junction box provided for direct wiring
- Aluminum blade
- Steel spiral wire guards
- Note: Rough-in hole size is 1/2" inch larger than fan blade size

Motor Specifications

- 120V, 1-Phase, totally enclosed, permanently lubricated
- 1/12 HP motor is 3-Speed sleeve bearing permanent split capacitor
- 1/8 HP motor is 3-Speed sleeve bearing permanent split capacitor
- 1/4 HP motor is 2-Speed ball bearing permanent split capacitor

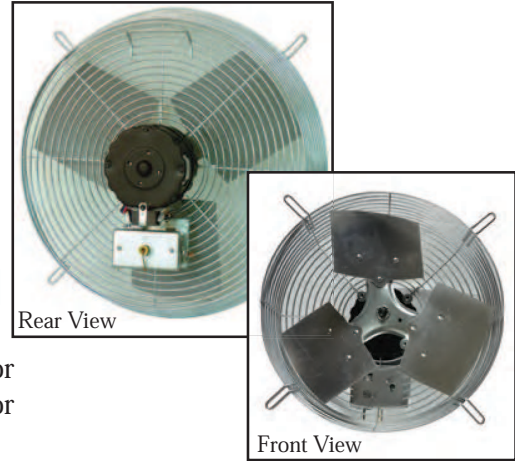

Standard Models

FAN SIZE	UPC# 686334	MODEL	HP	CFM / RPM			AMPS HIGH	WT. (LBS)
				HIGH	MED	LOW		
10"	868952	CE 10-D	1/12	680 / 1560	540 / 1250	460 / 1080	1	11
12"	798501	CE 12-D	1/12	825 / 1560	710 / 1250	560 / 1080	1.1	12
14"	868969	CE 14-D	1/8	1520 / 1660	1400 / 1550	1250 / 1370	2	17
16"	868976	CE 16-D	1/8	2100 / 1660	1900 / 1550	1700 / 1370	2.1	18
18"	798495	CE 18-D	1/8	2300 / 1660	2100 / 1050	1850 / 1370	2.2	19
20"	868983	CE 20-D	1/4	2925 / 1140	-	2380 / 1070	2.3	34
24"	798488	CE 24-D	1/4	3400 / 1140	-	2770 / 1070	2.5	38
30"	798471	CE 30-D	1/4	3950 / 1140	-	3080 / 1070	2.7	42

Dimensions (Inches)

SIZE	BOLT HOLE CENTER WIDTH	DEPTH
10"	14.14"	5.81"
12"	16.46"	7.18"
14"	18.30"	7.18"
16"	20.34"	7.18"
18"	22.64"	7.18"
20"	25.46"	7.18"
24"	29.08"	7.18"
30"	34.89"	7.18"

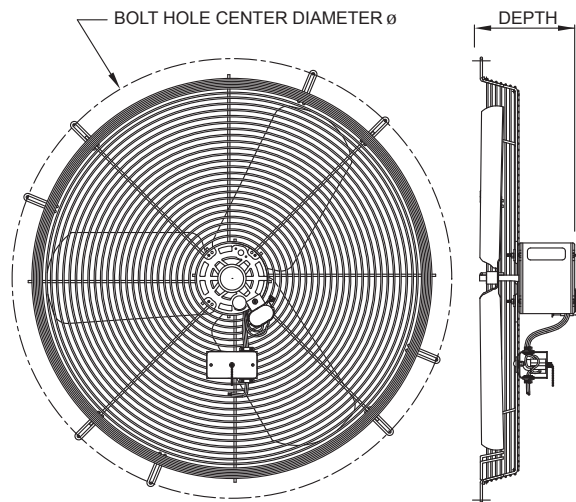

Optional Wall Shutters

FAN SIZE	UPC# 686334	MODEL	WT. (LBS)
10"	868433	CES-10G	5
12"	798556	CES-12G	5.5
14"	868457	CES-14G	6.5
16"	851473	CES-16G	8
18"	798563	CES-18G	9
20"	797528	CES-20G	10
24"	798570	CES-24G	13
30"	798587	CES-30G	19