



R2141-3

Siphon Jet Toilet - On Floor

Replacement Toilet for Most Vitreous China Closet Fixtures.

The **R2141 -3 Closet Fixture** is designed to replace a variety of existing front mount, free standing, on-floor fixtures with bottom waste outlet. Unit includes a contoured integral seat in addition to punching for hinged seat by others, a fully enclosed back and intended to meet most popular rough-ins at 10" and 12" from finished wall. Unit is fabricated from 16 gage, type 304 stainless steel and is seamless welded construction with exposed exterior & interior surfaces having a satin finish.

Toilet is Siphon Jet type with elongated bowl manufactured to ASME A112.19.3-2008 and CSA B45.4-2008 requirements and will flush with a minimum of 25 PSI flow pressure when used in conjunction with an appropriate flush valve. Trap has a minimum 3-1/2" seal, will pass a 2-1/8" ball and is fully enclosed. Floor flange is reinforced for maximum strength and includes 1-1/2" NPT flushing inlet connection and gasket waste outlet.

GUIDE SPECIFICATION

Provide and install Acorn Replacement Siphon Jet Toilet (specify model number and options). Fixture shall be fabricated from 16 gage, type 304 stainless steel. Construction shall be seamless welded and exposed surfaces shall have a satin finish with an integral contoured toilet seat. Toilet shall be concealed blowout jet type with an elongated bowl and a self-draining flushing rim. Toilet shall meet ASME A112.19.3-2008 and CSA B45.4-2008 requirements and will flush with a minimum of 25 PSI flow pressure. Toilet trap shall have a minimum 3-1/2" seal that shall pass a 2-1/8" diameter ball and be fully enclosed. Toilet waste outlet shall be gasket waste.



Must specify:

- R2141-T-3
- R2141-W-3

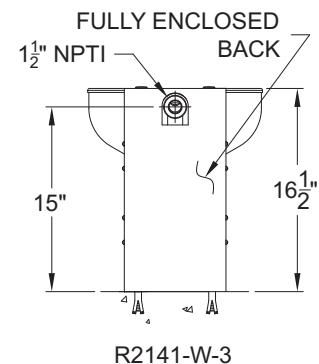
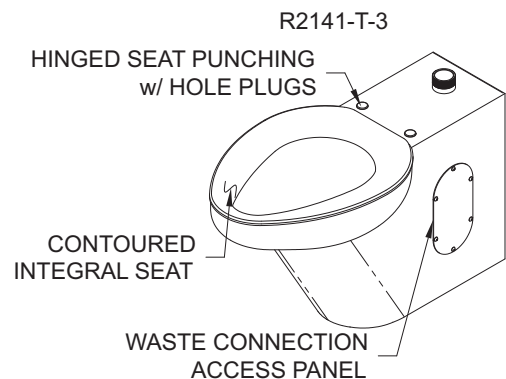
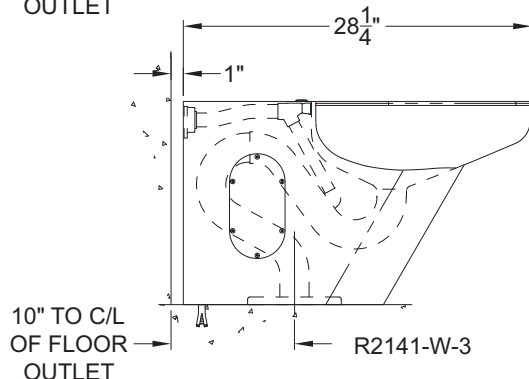
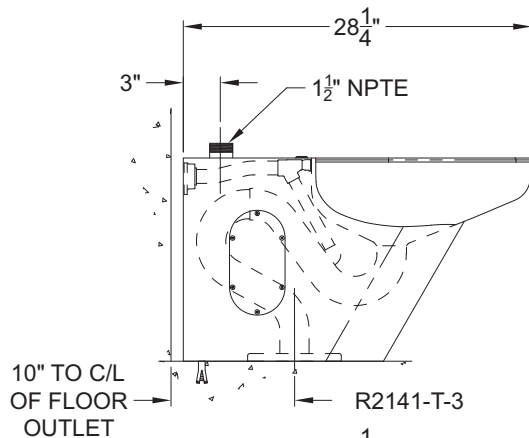

Please visit www.acorneng.com for most current specifications.