



No.:

Date: 27-DEC-2012

Customer :

TECHNICAL PROPOSAL

Three-phase induction motor - Squirrel cage rotor

Product line : Brake Motors : Three-Phase - High Efficiency

Catalog Number : 00718EP3EBM213T

List Price : \$2,640

Notes:

Performed by:

Checked:



No.:

Date: 27-DEC-2012

DATA SHEET

Three-phase induction motor - Squirrel cage rotor

Customer :
Product line : Brake Motors : Three-Phase - High Efficiency

Frame : 213T
Output : 7.5 HP
Frequency : 60 Hz
Poles : 4
Full load speed : 1765
Slip : 1.94 %
Voltage : 208-230/460 V
Rated current : 21.1-19.0/9.52 A
Locked rotor current : 122/60.9 A
Locked rotor current (I_L/I_n) : 6.4
No-load current : 9.26/4.63 A
Full load torque : 22.0 lb.ft
Locked rotor torque : 200 %
Breakdown torque : 260 %
Design : B
Insulation class : F
Temperature rise : 80 K
Locked rotor time : 21 s (hot)
Service factor : 1.25
Duty cycle : S1
Ambient temperature : -20°C - +40°C
Altitude : 1000
Degree of Protection : IP55
Approximate weight : 158 lb
Moment of inertia : 0.98005 sq.ft.lb
Noise level : 58 dB(A)

	D.E.	N.D.E.	Load	Power factor	Efficiency (%)
Bearings	6308 ZZ	6207 ZZ	100%	0.81	89.5
Regreasing interval	---	---	75%	0.75	89.5
Grease amount	---	---	50%	0.64	87.5

Notes:

Performed by

Checked



No.:

Date: 27-DEC-2012

PERFORMANCE CURVES RELATED TO RATED OUTPUT
Three-phase induction motor - Squirrel cage rotor

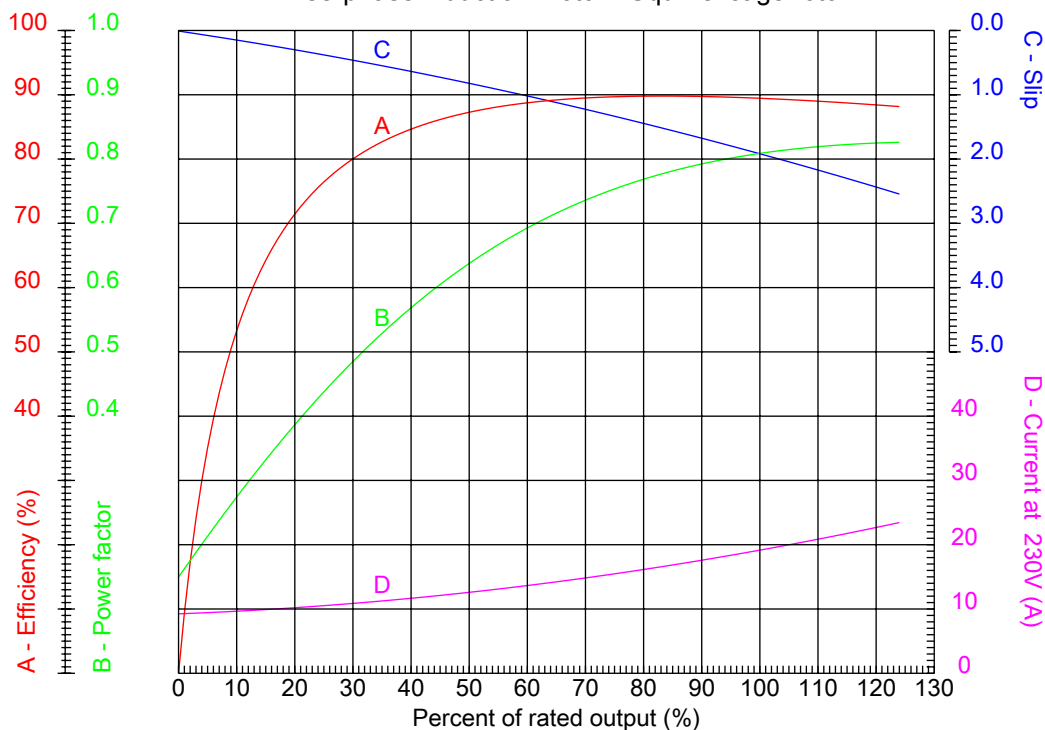

Customer :
Product line : Brake Motors : Three-Phase - High Efficiency

Frame	: 213T	Locked rotor current (I _l /I _n)	: 6.4
Output	: 7.5 HP	Duty cycle	: S1
Frequency	: 60 Hz	Service factor	: 1.25
Full load speed	: 1765	Design	: B
Voltage	: 208-230/460 V	Locked rotor torque	: 200 %
Rated current	: 21.1-19.0/9.52 A	Breakdown torque	: 260 %
Insulation class	: F		

Notes:

Performed by

Checked



No.:

Date: 27-DEC-2012

CHARACTERISTIC CURVES RELATED TO SPEED

Three-phase induction motor - Squirrel cage rotor

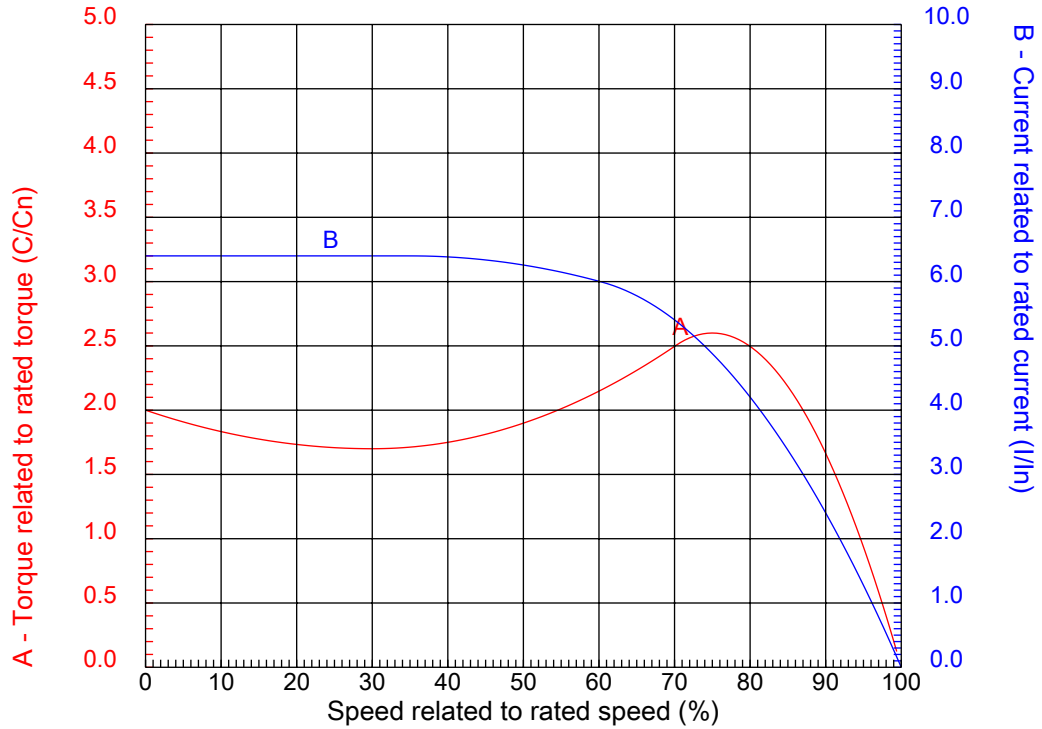

Customer :
Product line : Brake Motors : Three-Phase - High Efficiency

Frame	: 213T	Locked rotor current (I _l /I _n)	: 6.4
Output	: 7.5 HP	Duty cycle	: S1
Frequency	: 60 Hz	Service factor	: 1.25
Full load speed	: 1765	Design	: B
Voltage	: 208-230/460 V	Locked rotor torque	: 200 %
Rated current	: 21.1-19.0/9.52 A	Breakdown torque	: 260 %
Insulation class	: F		

Notes:

Performed by

Checked

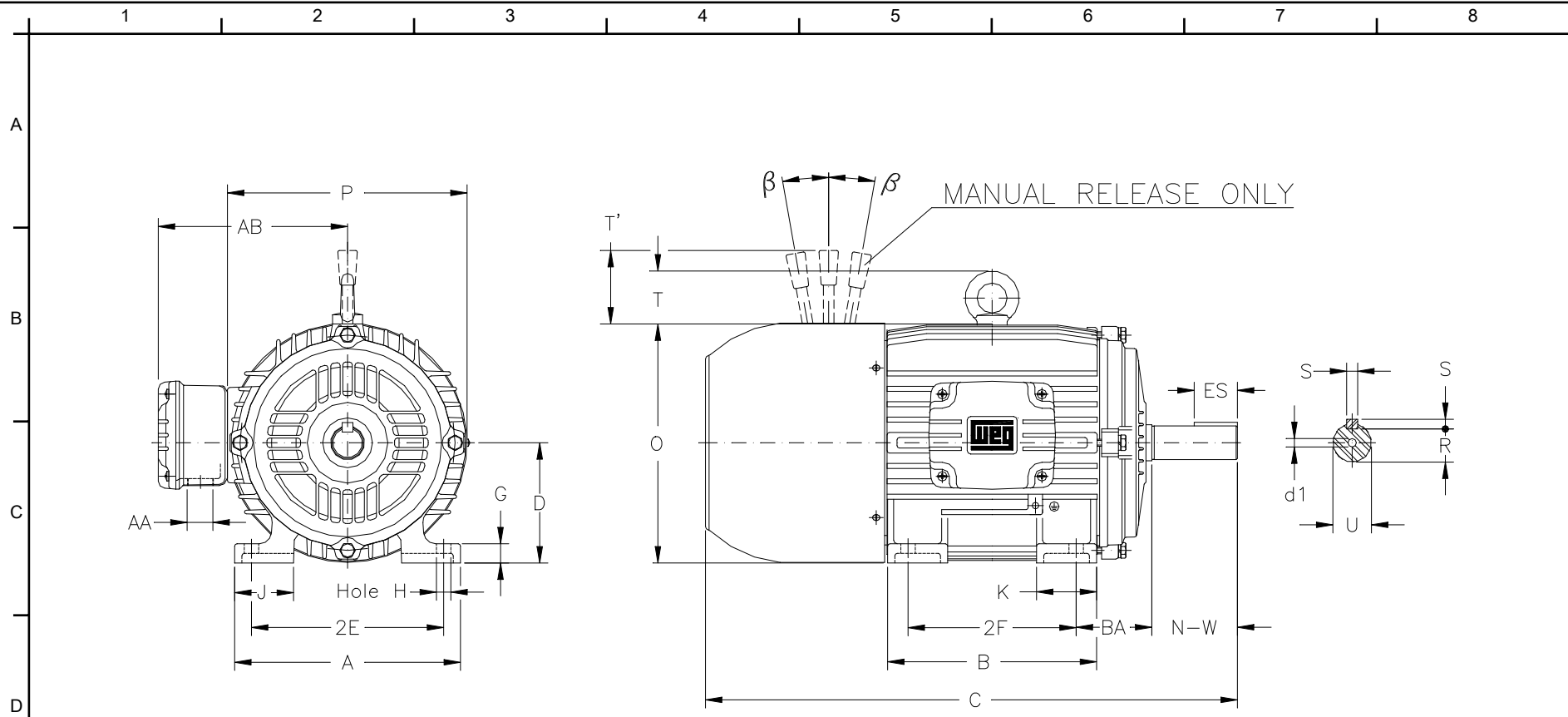

Notes:

2E 8.500	A 9.764	2F 5.500	B 7.362	BA 3.500
J 2.008	K 2.165	P 10.630	ES 2.480	depth 0.313
S 0.313	N-W 3.375	U 1.375	R 1.203	AB 8.149
D 5.250	G 0.827	O 10.841	T 1.772	HD 12.613
H 0.406	C 22.488	AA NPT 1"	d1 A 4	d2 A 4
Flange FD-254	AJ 10.000	AK 9.000	BD 11.000	BF 0.562
BB 0.203				

Performed by:

Checked:

Customer:

Brake Motors : Three-Phase - High Efficiency

Three-phase induction motor
Frame 213T - IP55

27-DEC-2012

