



No.:

Date: 27-DEC-2012

Customer :

TECHNICAL PROPOSAL

Three-phase induction motor - Squirrel cage rotor

Product line : Three-Phase : Explosion Proof - NEMA Premium

Catalog Number : 02518XT3E284TC

List Price : \$4,262

Notes:

Performed by:

Checked:



No.:

Date: 27-DEC-2012

## DATA SHEET

### Three-phase induction motor - Squirrel cage rotor

Customer :  
Product line : Three-Phase : Explosion Proof - NEMA Premium

Frame : 284T  
Output : 25 HP  
Frequency : 60 Hz  
Poles : 4  
Full load speed : 1775  
Slip : 1.39 %  
Voltage : 208-230/460 V  
Rated current : 66.1-59.8/29.9 A  
Locked rotor current : 490/245 A  
Locked rotor current (I<sub>L</sub>/I<sub>n</sub>) : 8.2  
No-load current : 27.0/13.5 A  
Full load torque : 73.0 lb.ft  
Locked rotor torque : 300 %  
Breakdown torque : 300 %  
Design : B  
Insulation class : F  
Temperature rise : 80 K  
Locked rotor time : 20 s (hot)  
Service factor : 1.15  
Duty cycle : S1  
Ambient temperature : -20°C - +40°C  
Altitude : 1000  
Degree of Protection : IP54  
Approximate weight : 472 lb  
Moment of inertia : 4.5426 sq.ft.lb  
Noise level : 68 dB(A)

	D.E.	N.D.E.	Load	Power factor	Efficiency (%)
Bearings	6311 C3	6211 Z-C3	100%	0.83	93.6
Regreasing interval	20000 h	20000 h	75%	0.78	93.6
Grease amount	18 g	11 g	50%	0.67	92.4

Notes:

Performed by

Checked



No.:

Date: 27-DEC-2012

PERFORMANCE CURVES RELATED TO RATED OUTPUT  
Three-phase induction motor - Squirrel cage rotor

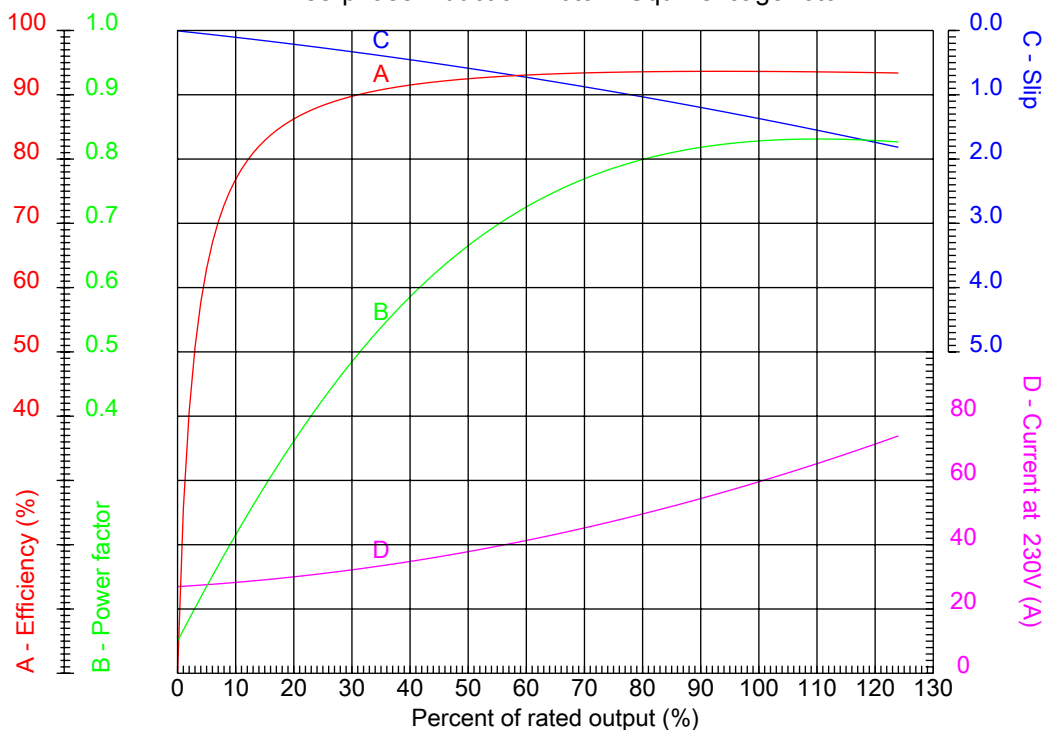

Customer :  
Product line : Three-Phase : Explosion Proof - NEMA Premium

Frame : 284T	Locked rotor current (I <sub>L</sub> /I <sub>n</sub> ) : 8.2
Output : 25 HP	Duty cycle : S1
Frequency : 60 Hz	Service factor : 1.15
Full load speed : 1775	Design : B
Voltage : 208-230/460 V	Locked rotor torque : 300 %
Rated current : 66.1-59.8/29.9 A	Breakdown torque : 300 %
Insulation class : F	

Notes:

Performed by

Checked



No.:

Date: 27-DEC-2012

### CHARACTERISTIC CURVES RELATED TO SPEED

Three-phase induction motor - Squirrel cage rotor

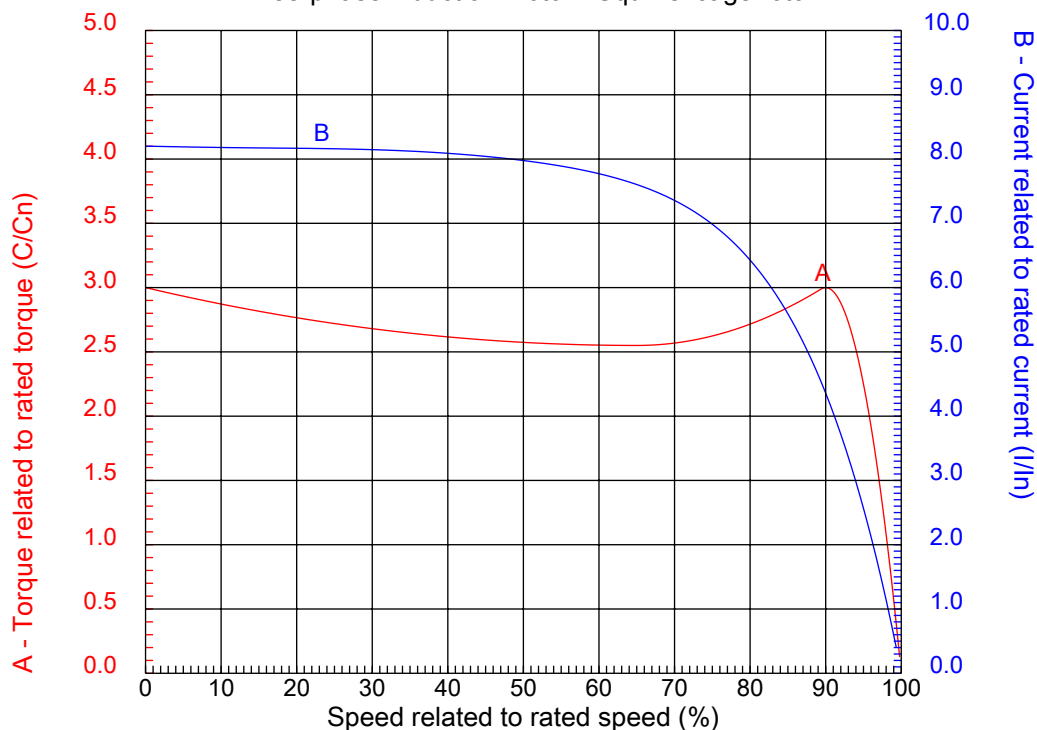

Customer :  
Product line : Three-Phase : Explosion Proof - NEMA Premium

Frame	: 284T	Locked rotor current (I <sub>l</sub> /I <sub>n</sub> )	: 8.2
Output	: 25 HP	Duty cycle	: S1
Frequency	: 60 Hz	Service factor	: 1.15
Full load speed	: 1775	Design	: B
Voltage	: 208-230/460 V	Locked rotor torque	: 300 %
Rated current	: 66.1-59.8/29.9 A	Breakdown torque	: 300 %
Insulation class	: F		

Notes:

Performed by

Checked

1 2 3 4 5 6 7 8

A

B

C

D

E

F

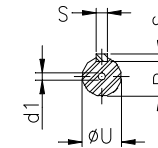
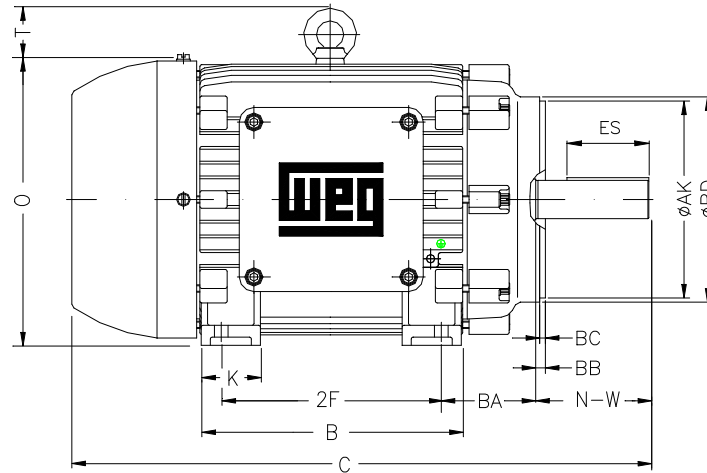
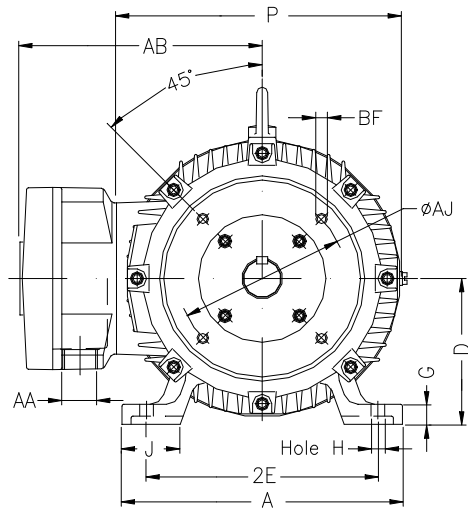

Notes:

Performed by:

Checked:

Customer:

Three-Phase : Explosion Proof - NEMA Premium

Three-phase induction motor  
Frame 284T - IP54

27-DEC-2012



2E 11.000	A 13.780	2F 9.500	B 11.575	BA 4.750
J 3.150	K 2.953	P 14.094	ES 3.149	depth 0.500
S 0.500	N-W 4.622	U 1.875	R 1.594	AB 11.850
D 7.000	G 1.024	O 14.362	HD 16.803	H 0.531
C 26.407	AA NPT 1 1/2"	d1 A 4	d2 A 4	T 2.441
Flange FC-228	AJ 9.000	AK 10.500	BD 11.031	BF UNC 1/2"x13
BB 0.250	BC 0.250	AH 4.375		