



No.:

Date: 27-DEC-2012

Customer :

TECHNICAL PROPOSAL

Three-phase induction motor - Squirrel cage rotor

Product line : Three-Phase : Explosion Proof - NEMA Premium

Catalog Number : 04018XT3E324T

List Price : \$5,380

Notes:

Performed by:

Checked:



No.:

Date: 27-DEC-2012

DATA SHEET

Three-phase induction motor - Squirrel cage rotor

Customer :
Product line : Three-Phase : Explosion Proof - NEMA Premium

Frame : 324T
Output : 40 HP
Frequency : 60 Hz
Poles : 4
Full load speed : 1780
Slip : 1.11 %
Voltage : 208-230/460 V
Rated current : 107-96.4/48.2 A
Locked rotor current : 742/371 A
Locked rotor current (I_L/I_n) : 7.7
No-load current : 46.0/23.0 A
Full load torque : 116 lb.ft
Locked rotor torque : 270 %
Breakdown torque : 300 %
Design : B
Insulation class : F
Temperature rise : 80 K
Locked rotor time : 19 s (hot)
Service factor : 1.15
Duty cycle : S1
Ambient temperature : -20°C - +40°C
Altitude : 1000
Degree of Protection : IP54
Approximate weight : 650 lb
Moment of inertia : 8.1664 sq.ft.lb
Noise level : 71 dB(A)

	D.E.	N.D.E.	Load	Power factor	Efficiency (%)
Bearings	6312 C3	6212 Z-C3	100%	0.83	94.1
Regreasing interval	20000 h	20000 h	75%	0.77	94.1
Grease amount	21 g	13 g	50%	0.66	93.0

Notes:

Performed by

Checked



No.:

Date: 27-DEC-2012

PERFORMANCE CURVES RELATED TO RATED OUTPUT
 Three-phase induction motor - Squirrel cage rotor

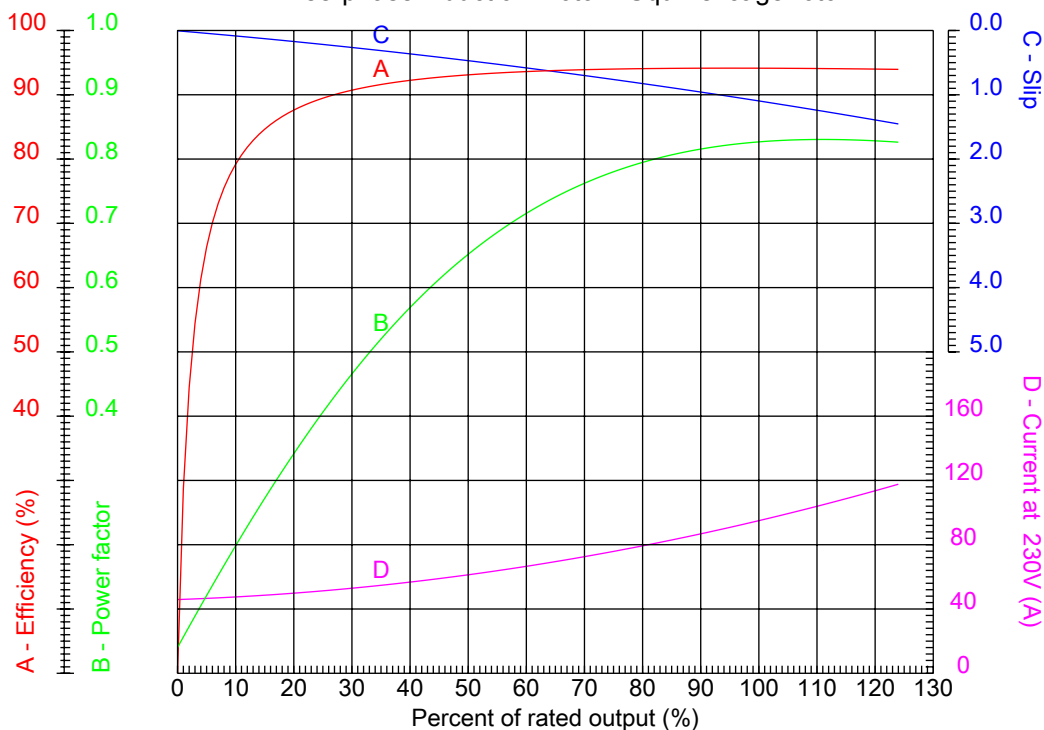

Customer :
 Product line : Three-Phase : Explosion Proof - NEMA Premium

Frame : 324T	Locked rotor current (I _L /I _n) : 7.7
Output : 40 HP	Duty cycle : S1
Frequency : 60 Hz	Service factor : 1.15
Full load speed : 1780	Design : B
Voltage : 208-230/460 V	Locked rotor torque : 270 %
Rated current : 107-96.4/48.2 A	Breakdown torque : 300 %
Insulation class : F	

Notes:

Performed by _____ Checked _____



No.:

Date: 27-DEC-2012

CHARACTERISTIC CURVES RELATED TO SPEED

Three-phase induction motor - Squirrel cage rotor

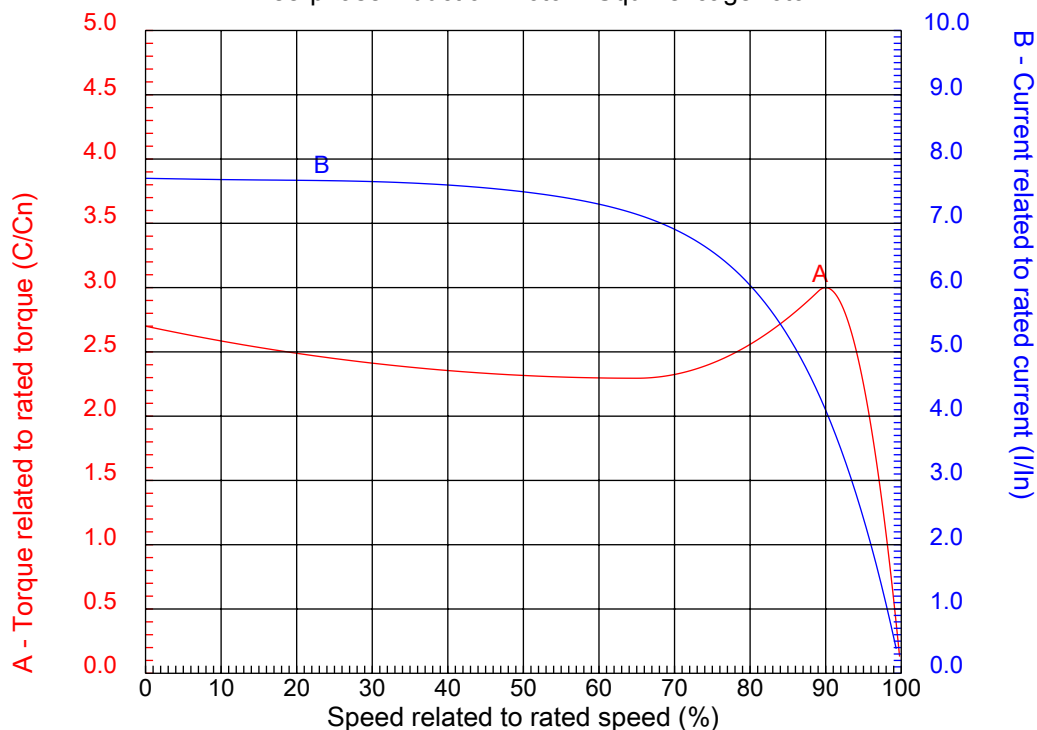

Customer :
Product line : Three-Phase : Explosion Proof - NEMA Premium

Frame	: 324T	Locked rotor current (I _l /I _n)	: 7.7
Output	: 40 HP	Duty cycle	: S1
Frequency	: 60 Hz	Service factor	: 1.15
Full load speed	: 1780	Design	: B
Voltage	: 208-230/460 V	Locked rotor torque	: 270 %
Rated current	: 107-96.4/48.2 A	Breakdown torque	: 300 %
Insulation class	: F		

Notes:

Performed by

Checked

1 2 3 4 5 6 7 8

A

B

C

D

E

F

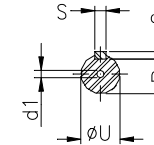
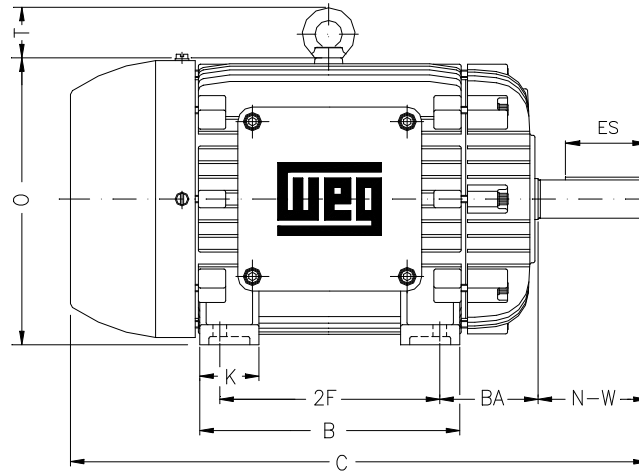
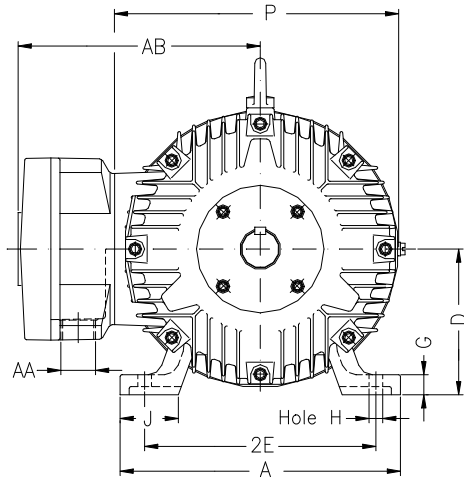

Notes:

Performed by:

Checked:

Customer:

Three-Phase : Explosion Proof - NEMA Premium

Three-phase induction motor
Frame 324T - IP54

27-DEC-2012



2E 12.500	A 15.157	2F 10.500	B 13.071	BA 5.250
J 3.228	K 3.346	P 15.697	ES 3.937	depth 0.500
S 0.500	N-W 5.250	U 2.125	R 1.844	AB 12.961
D 8.000	G 1.307	O 15.992	HD 18.787	H 0.657
C 29.602	AA NPT 2"	d1 A 4	d2 A 4	T 2.795
Flange FD-406	AJ 16.000	AK 14.000	BD 18.000	BF 0.828
BB 0.203				