



No.:

Date: 24-DEC-2012

Customer :

TECHNICAL PROPOSAL

Three-phase induction motor - Squirrel cage rotor

Product line : Three-Phase: W22 IE3 IEC Tru-Metric - TEFC (IP55) Cast Iron Frame

Catalog Number : 02218ET3Y180L-W22

List Price : \$3,225

Notes:

Performed by:

Checked:



No.:

Date: 24-DEC-2012

DATA SHEET

Three-phase induction motor - Squirrel cage rotor

Customer :
Product line : Three-Phase: W22 IE3 IEC Tru-Metric - TEFC (IP55) Cast Iron Frame

Frame : 180L
Output : 30 HP
Frequency : 60 Hz
Poles : 4
Full load speed : 1775
Slip : 1.39 %
Voltage : 460 V
Rated current : 36.0 A
Locked rotor current : 310 A
Locked rotor current (I_L/I_n) : 8.6
No-load current : 16.8 A
Full load torque : 87.6 lb.ft
Locked rotor torque : 350 %
Breakdown torque : 390 %
Design : N
Insulation class : F
Temperature rise : 80 K
Locked rotor time : 19 s (hot)
Service factor : 1.25
Duty cycle : S1
Ambient temperature : -20°C - +40°C
Altitude : 1000
Degree of Protection : IP55
Approximate weight : 437 lb
Moment of inertia : 5.3919 sq.ft.lb
Noise level : 64 dB(A)

	D.E.	N.D.E.	Load	Power factor	Efficiency (%)
Bearings	6311 C3	6211 C3	100%	0.82	93.6
Regreasing interval	20000 h	20000 h	75%	0.76	92.4
Grease amount	18 g	11 g	50%	0.65	91.0

Notes:

Performed by

Checked



No.:

Date: 24-DEC-2012

PERFORMANCE CURVES RELATED TO RATED OUTPUT

Three-phase induction motor - Squirrel cage rotor

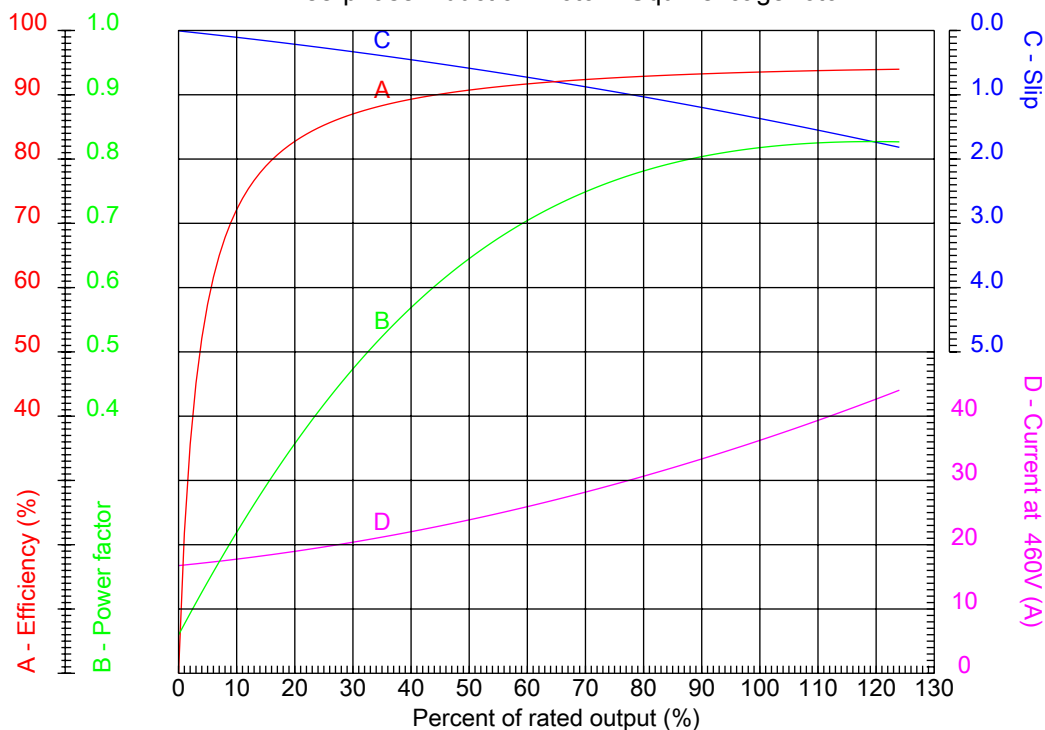

Customer :
Product line : Three-Phase: W22 IE3 IEC Tru-Metric - TEFC (IP55) Cast Iron Frame

Frame	: 180L	Locked rotor current (I _l /I _n)	: 8.6
Output	: 30 HP	Duty cycle	: S1
Frequency	: 60 Hz	Service factor	: 1.25
Full load speed	: 1775	Design	: N
Voltage	: 460 V	Locked rotor torque	: 350 %
Rated current	: 36.0 A	Breakdown torque	: 390 %
Insulation class	: F		

Notes:

Performed by

Checked



No.:

Date: 24-DEC-2012

CHARACTERISTIC CURVES RELATED TO SPEED Three-phase induction motor - Squirrel cage rotor

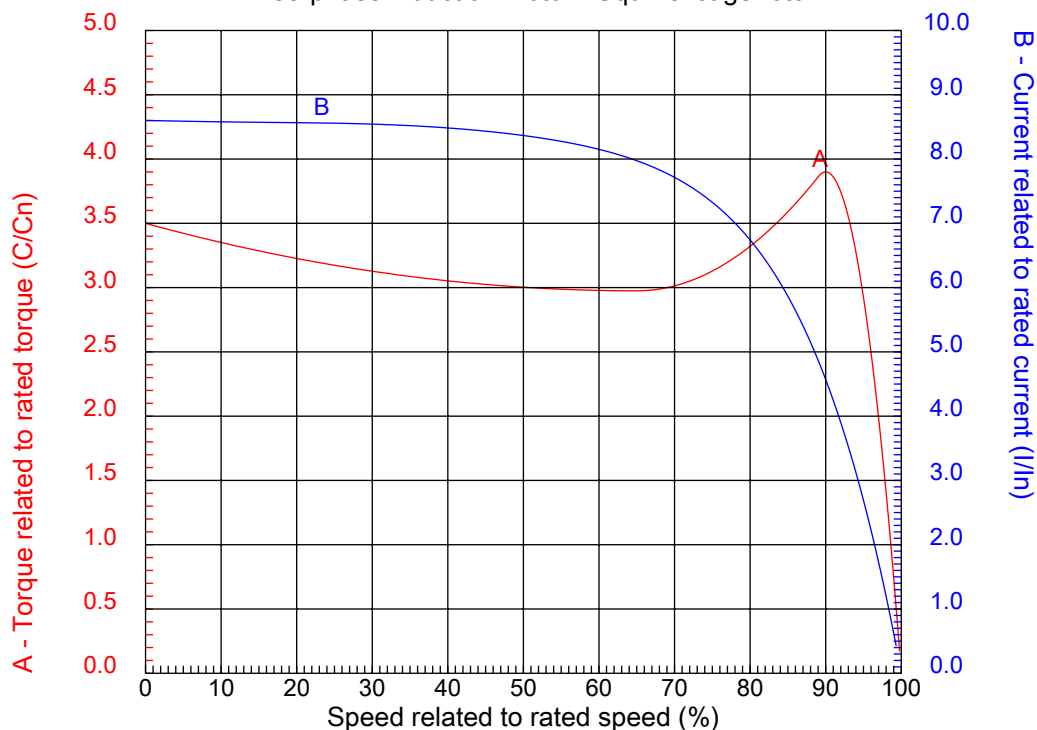

Customer :
Product line : Three-Phase: W22 IE3 IEC Tru-Metric - TEFC (IP55) Cast Iron Frame

Frame	: 180L	Locked rotor current (I _l /I _n)	: 8.6
Output	: 30 HP	Duty cycle	: S1
Frequency	: 60 Hz	Service factor	: 1.25
Full load speed	: 1775	Design	: N
Voltage	: 460 V	Locked rotor torque	: 350 %
Rated current	: 36.0 A	Breakdown torque	: 390 %
Insulation class	: F		

Notes:

Performed by

Checked

1 2 3 4 5 6 7 8

A

B

C

D

E

F

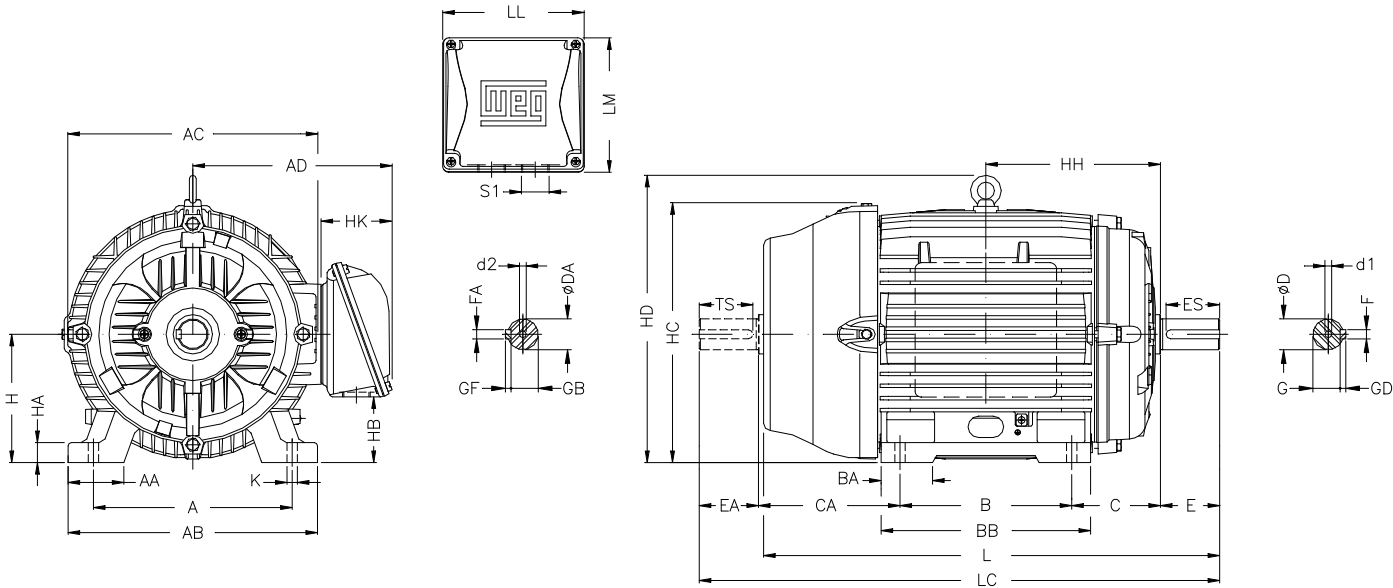

A	AA	AB	AC	AD
279	78	350	360	279
B	BA	BB	C	CA
279	70	332	121	200
D	E	ES	F	G
48k6	110	80	14	42.5
GD	DA	EA	TS	FA
9	48k6	110	80	14
GB	GF	H	HA	HC
42.5	9	180	28	363
HD	K	L	LC	S1
413	14.5	702	820	2XM40X1,5
d1	d2	Flange	LA	M
DM16	DM16	FF-300	18	300
N	P	T	S	Angle
250	350	5	19	45°
Holes				
4				

Notes:

Performed by:

Checked:

Customer:

Three-Phase: W22 IE3 IEC Tru-Metric - TEFC (IP55) Cast Iron Frame

Three-phase induction motor
Frame 180L - IP55

24-DEC-2012

