



No.:

Date: 24-DEC-2012

Customer :

TECHNICAL PROPOSAL

Three-phase induction motor - Squirrel cage rotor

Product line : Three-Phase: W22 IE3 IEC Tru-Metric - TEFC (IP55) Cast Iron Frame

Catalog Number : 07518ET3Y280S/M-W22

List Price : \$12,353

Notes:

Performed by:

Checked:



No.:

Date: 24-DEC-2012

DATA SHEET

Three-phase induction motor - Squirrel cage rotor

Customer :
Product line : Three-Phase: W22 IE3 IEC Tru-Metric - TEFC (IP55) Cast Iron Frame

Frame : 280S/M
Output : 100 HP
Frequency : 60 Hz
Poles : 4
Full load speed : 1785
Slip : 0.83 %
Voltage : 460 V
Rated current : 116 A
Locked rotor current : 916 A
Locked rotor current (I_L/I_n) : 7.9
No-load current : 43.9 A
Full load torque : 290 lb.ft
Locked rotor torque : 270 %
Breakdown torque : 340 %
Design : N
Insulation class : F
Temperature rise : 80 K
Locked rotor time : 47 s (hot)
Service factor : 1.25
Duty cycle : S1
Ambient temperature : -20°C - +40°C
Altitude : 1000
Degree of Protection : IP55
Approximate weight : 1607 lb
Moment of inertia : 53.483 sq.ft.lb
Noise level : 73 dB(A)

	D.E.	N.D.E.	Load	Power factor	Efficiency (%)
Bearings	6316 C3	6316 C3	100%	0.85	95.4
Regreasing interval	10000 h	10000 h	75%	0.81	94.5
Grease amount	34 g	34 g	50%	0.72	93.0

Notes:

Performed by

Checked



No.:

Date: 24-DEC-2012

PERFORMANCE CURVES RELATED TO RATED OUTPUT

Three-phase induction motor - Squirrel cage rotor

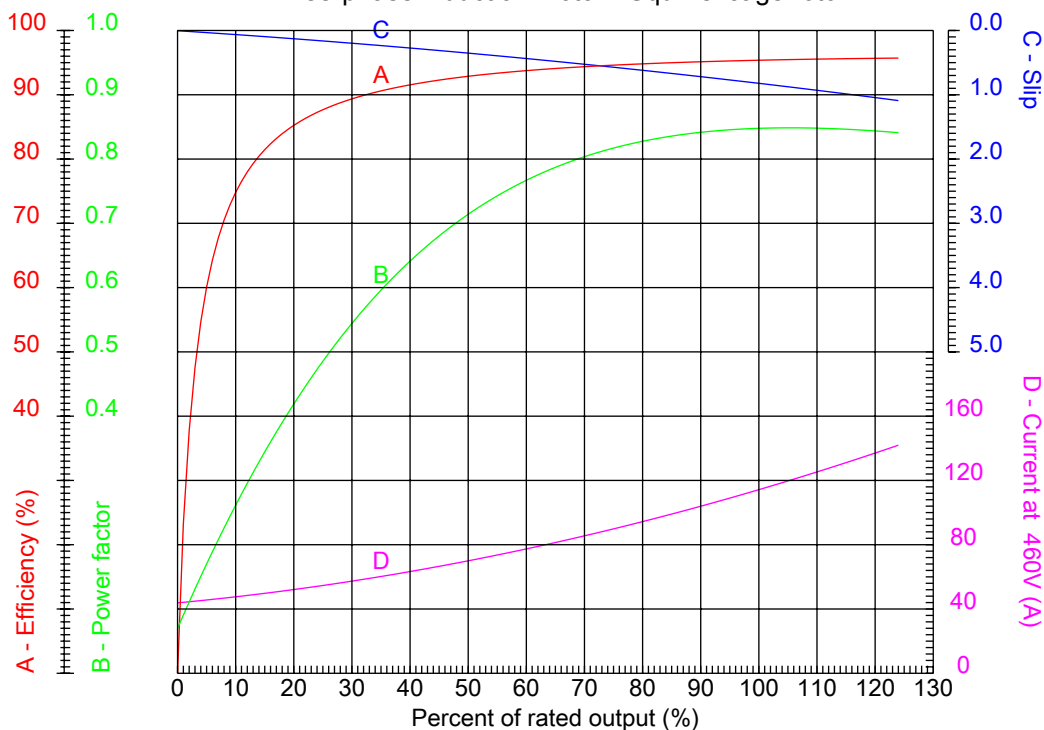

Customer :
Product line : Three-Phase: W22 IE3 IEC Tru-Metric - TEFC (IP55) Cast Iron Frame

Frame : 280S/M	Locked rotor current (I _l /I _n) : 7.9
Output : 100 HP	Duty cycle : S1
Frequency : 60 Hz	Service factor : 1.25
Full load speed : 1785	Design : N
Voltage : 460 V	Locked rotor torque : 270 %
Rated current : 116 A	Breakdown torque : 340 %
Insulation class : F	

Notes:

Performed by

Checked



No.:

Date: 24-DEC-2012

CHARACTERISTIC CURVES RELATED TO SPEED

Three-phase induction motor - Squirrel cage rotor

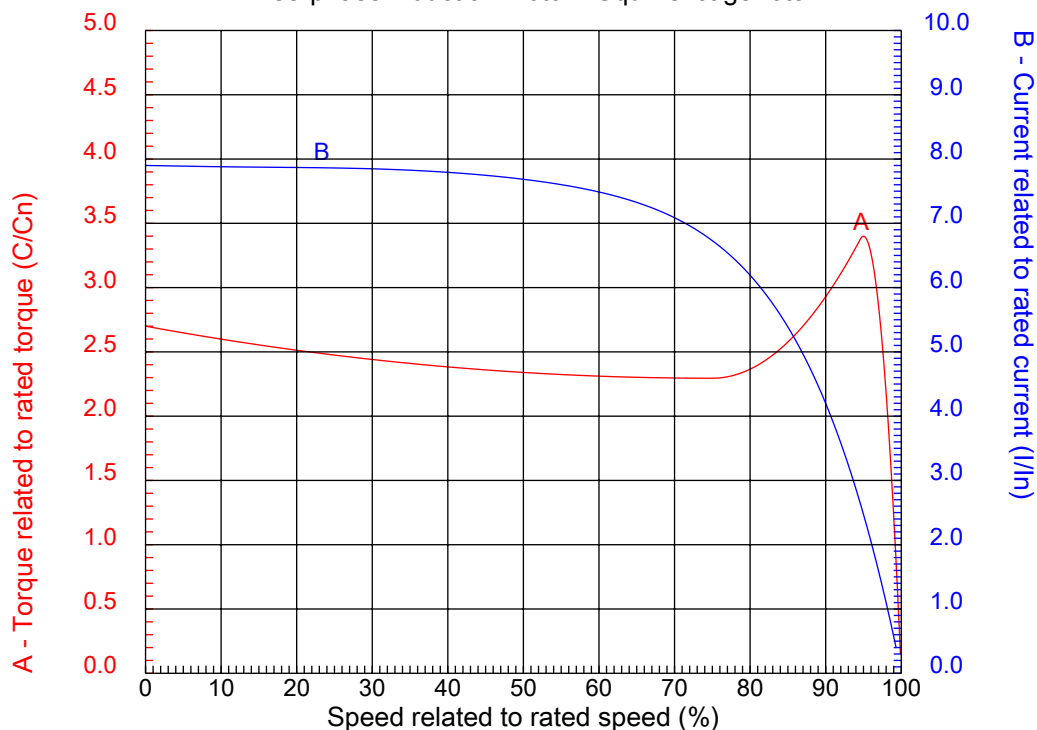

Customer :
Product line : Three-Phase: W22 IE3 IEC Tru-Metric - TEFC (IP55) Cast Iron Frame

Frame	: 280S/M	Locked rotor current (I _l /I _n)	: 7.9
Output	: 100 HP	Duty cycle	: S1
Frequency	: 60 Hz	Service factor	: 1.25
Full load speed	: 1785	Design	: N
Voltage	: 460 V	Locked rotor torque	: 270 %
Rated current	: 116 A	Breakdown torque	: 340 %
Insulation class	: F		

Notes:

Performed by

Checked

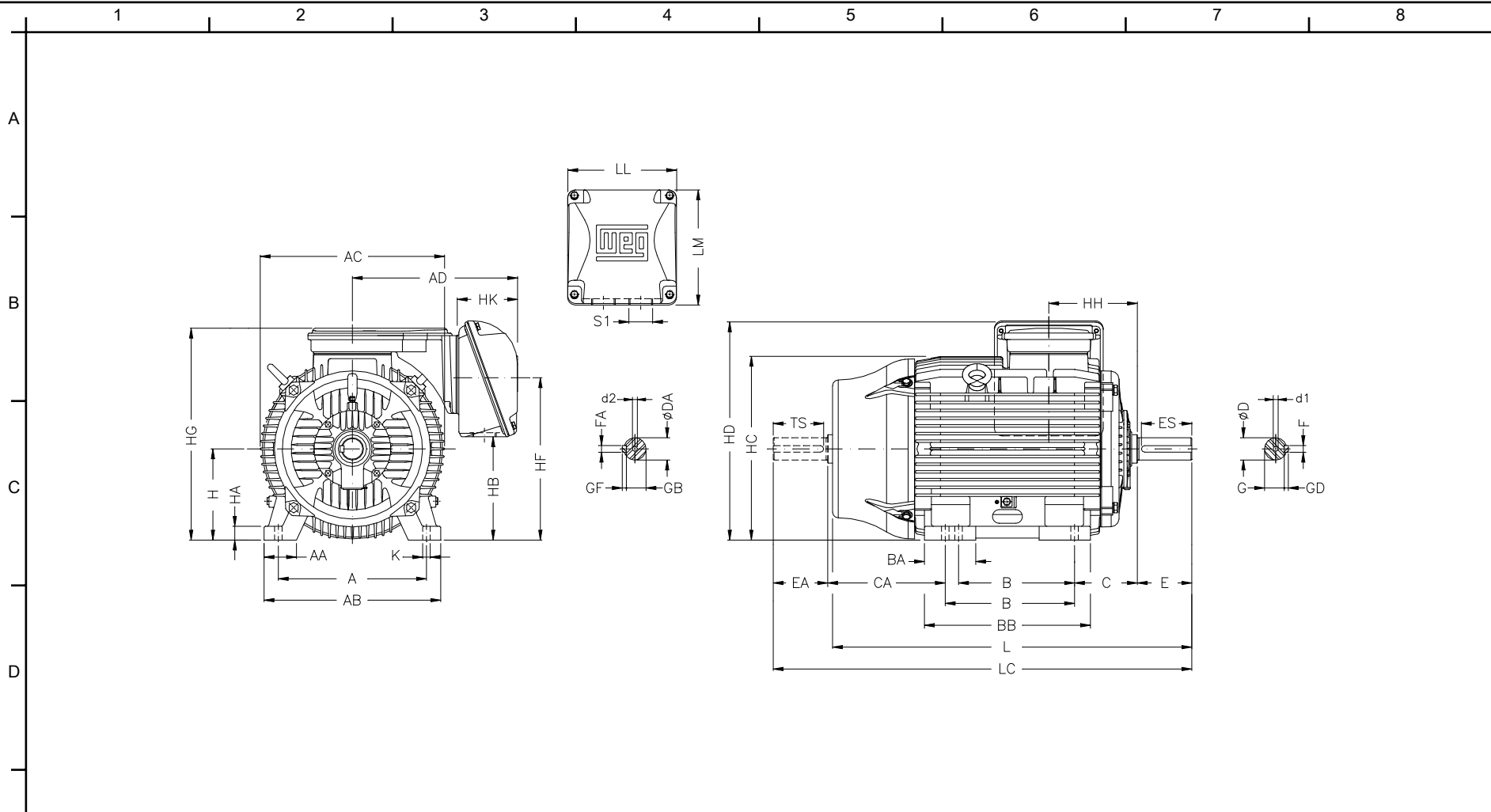

	A 457	AA 100	AB 557	AC 599	AD 450	Notes:
E	B 368/419	BA 151	BB 517	C 190	CA 385/334	
	D 75m6	E 140	ES 125	F 20	G 67.5	Performed by:
	GD 12	DA 65m6	EA 140	TS 125	FA 18	Checked:
	GB 58	GF 11	H 280	HA 42	HC 580	Customer:
	HD 696	K 24	L 1071	LC 1223	S1 2XM63X1,5	Three-Phase: W22 IE3 IEC Tru-Metric - TEFC (IP55) Cast Iron Frame
F	d1 DM20	d2 DM20	Flange FF-500	LA 18	M 500	Three-phase induction motor Frame 280S/M - IP55
	N 450	P 550	T 5	S 19	Angle 22°30'	
	Holes 8					24-DEC-2012

