



Installation and Maintenance Manual

Please retain this manual for future reference.

S405

Construction Heater

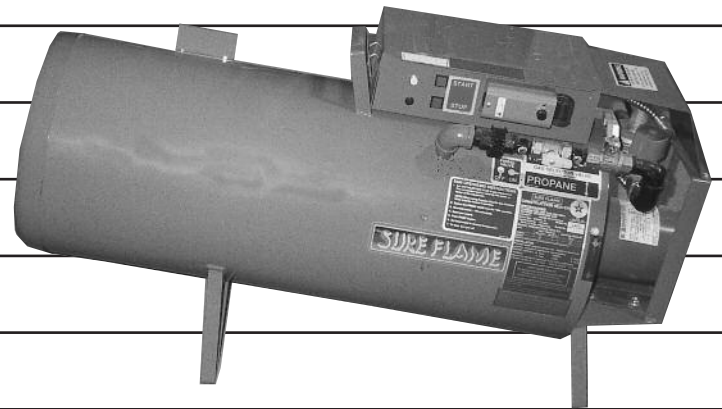

For your safety: Do not use this heater in a space where gasoline or other liquids having flammable vapors are stored.

IMPORTANT INFORMATION! READ FIRST

The heater is designed for use as a construction heater under ANSI Z83.7a-1993. Heater is not intended for use in pest remediation. The primary purpose of construction heaters is to provide temporary heating of buildings under construction, alteration, or repair and to provide emergency heat. Properly used, the heater provides safe, economical heating. Products of combustion are vented into the area being heated.

The heater **IS NOT** designed as an Unvented Gas Fired Room Heater under ANSI-Z21.11.2 and **SHOULD NOT** be used in the home.

ANSI A119.2(NFPA 501C)-1987 Recreational Vehicle Standard prohibits the installation or storage of LP-gas containers even temporarily inside any recreational vehicle. The standard also prohibits the use of Unvented Heaters in such vehicles.

NFPA-58 1989 STANDARD FOR THE STORAGE AND HANDLING OF LIQUEFIED PETROLEUM GASES

Use of the heater must be in accordance with this Standard and in compliance with all governing state and local codes. Storage and handling of propane gas and propane cylinders must be in accordance with NFPA 58 and all local governing codes.

We cannot anticipate every use which may be made for our heaters. **CHECK WITH YOUR LOCAL FIRE SAFETY AUTHORITY IF YOU HAVE QUESTIONS ABOUT LOCAL REGULATIONS.**

Other standards govern the use of fuel gases and heat producing products in specific applications. Your local authority can advise you about these.

FOR YOUR SAFETY

DO NOT USE THIS HEATER IN A SPACE WHERE GASOLINE OR OTHER LIQUIDS HAVING FLAMMABLE VAPORS ARE STORED OR USED.

CONSTRUCTION HEATER GENERAL HAZARD WARNING:

Failure to comply with the precautions and instructions provided with this heater, can result in death, serious bodily injury and property loss or damage from hazards of fire, explosion, burn, asphyxiation, carbon monoxide poisoning, and/or electrical shock.

Only persons who can understand and follow the instructions should use or service this heater.

If you need assistance or heater information such as an instruction manual, labels, etc. Contact your local Heat Wagon dealer or the manufacturer.

W A R N I N G

Fire, burn, inhalation, and explosion hazard. Keep solid combustibles, such as building materials, paper or cardboard, a safe distance away from the heater as recommended by the instructions. Never use the heater in spaces which do or may contain volatile or airborne combustibles, or products such as gasoline, solvents, paint thinner, dust particles or unknown chemicals.

Not for home or recreational vehicle use!

Installation and Maintenance Manual

Model S405

Construction Heater

Table of Contents:

	Page
Specifications	4
Installation	5
Proper Set Up	6
On-site Safety Problems & Operating Instructions	7
Preventative Maintenance	8
Trouble Shooting	9
Parts Breakdown	10
Wiring Diagrams	11-14

WARRANTY

All new Heat Wagon and Sure Flame heaters and fans are guaranteed against defective materials and workmanship for one (1) year from Heat Wagon invoice date.

Warranty repairs may be made only by an authorized, trained and certified Heat Wagon dealer. Warranty repairs by other entities will not be considered. Warranty claims must include model number and serial number.

LIMITATIONS

Warrant claims for service parts (wear parts) such as spark plugs, igniters, flame rods will not be allowed. Diagnostic parts such as voltage meters and pressure gauges are not warrantable.

Evidence of improper fuel usage, fuel pressures outside of manufacturer's specification, poor fuel quality, and improper electric power, misapplication or evidence of abuse may be cause for rejection of warranty claims.

Travel time, mileage and shipping charges will not be allowed. Minor adjustments of heaters are dealers' responsibility. Defective parts must be tagged and held for possible return to the factory for 60 days from date of repair. The factory will provide a return goods authorization, (RGA) for defective parts to be returned.

No warranty will be allowed for parts not purchased from Heat Wagon.

DESIGN RELATED SAFETY FEATURES

1. Locking position for LPG on gas selector lever: Units used with LPG while the gas selector valve is positioned for Natural Gas will throw significantly more heat than the rated Btu/h. This is definitely a safety hazard.
2. Low Skin Temperature: Sure Flame Heaters are designed to have a low skin temperature. This provides added safety in the workplace.
3. Durable Construction: The Model S405 uses a stainless steel burner for long life and consistent performance.

In order to maintain the highly efficient combustion of the Sure Flame Heater, the combustion chamber must remain as manufactured. Any change or distortion could alter the fuel/air mixture and create unwanted gases.

SAFETY FEATURES

Servicing of Sure Flame Construction Heaters normally involves one of several built-in safety features. The Model S405 incorporates devices to detect the following:

1. LOSS OF FLAME Gas supply is shut off if flame is lost to prevent raw gas from leaving heater
2. OVERHEATING a) Thermal overload protection in the motor
b) High temperature limit switch in the control box
3. LOSS OF POWER Total shutdown with manual reset required. Any one of the safety devices will create a loss of power situation
4. BLOCKED AIR SUPPLY An airflow switch detects the differential pressure in the combustion chamber and shuts down when insufficient

SPECIFICATIONS

Model No. S405

Designed to ANSI Z83.7a-1993 Construction Heater

Gases:	Natural or Propane Vapor
Capacity:	400,000 Btu/h maximum
Orifice Size:	42 DMS (x18)
Blower:	2,000 CFM
Electrical Rating:	115V 60Hz 12 amps, single phase
Minimum Temperature Rating:	Minus 40 degrees F

Gas Supply:	Inlet Pressure		Manifold Pressure	
	Max W.C.	Min W.C.	W.C.	W.C.
Propane	14"	7" W.C.	1.3"	
Natural Gas	14"	7" W.C.	4.0"	

(Minimum inlet pressure is for purpose of input adjustment)

Inlet Connection:	Weight (approximate): 100 lbs.
Model S405 1" NPT	

INSTALLATION

The **Sure Flame S405** is a direct fired gas heater intended to be used primarily for the temporary heating of buildings under construction, alteration, or repair. Since all the products of combustion are released into the area being heated, it is imperative that adequate ventilation is provided. The flow of supply air and combustion gases must not be obstructed in any way. Do not use the heater with ductwork as this will restrict the flow supply air.

1. Install the heater in a horizontal position and allow the following clearances from any combustible material or fuel containers:

Front Outlet:	12 feet	Sides:	2 feet
Intake:	2 feet	Top:	5 feet

Front outlet must not be directed at any LP-Gas container within 20 feet.

Also make sure that no flammable vapors are present in the space where the heaters is being used.

2. When connecting the heater to a natural gas or propane supply line ensure that the pressure at the heater inlet is within the specified range. Please refer to Propane and Natural Gas installation sections on page 6. Excessive pressure (over 1/2" psig) will damage the controls and void the warranty.
3. Visually inspect the hose assembly and ensure that it is protected from traffic, building materials, and contact with hot surfaces. If it is evident that there is excessive abrasion or wear, or the hose is cut, it must be replaced.
4. After installation, check the hose assembly for gas leaks by applying a water and soap solution to each connection.
5. Connect the heater to an adequate 115 volt electrical supply and in compliance with the National Electrical Code ANSI/NFPA 7.0. For protection against shock hazard the supply cord should be plugged directly into a properly grounded three-prong receptacle.
6. In all applications, install the heater in such a manner that it is not directly exposed to water spray, rain, and/or dripping water.

PROPER SET-UP

- 1) When installing the heater for use with propane gas, set the gas selector to "Propane" and lock in position.
- 2) The supply container **must** be equipped with an LP Gas Regulator that complies with ANSI/UL 144 Standard for Pressure Regulating Valves for LP Gas. Another regulator must be installed on the heater to reduce the pressure from this regulator down to a maximum inlet pressure of 1/2 psig.
- 3) Arrange the cylinder supply system to provide for vapor withdrawal from the operating cylinder. Supplying liquid propane to the heater is dangerous and will damage the components.
- 4) Ensure that for the surrounding temperature the size and capacity of the propane supply cylinder is adequate to provide the rated BTU/H input to the heater.
- 5) Turn off the propane supply valve at the cylinder when the heater is not in use.
- 6) The installation must conform with local codes, or in the absence of local codes, with the Standard for Storage and Handling of Liquefied Petroleum Gases ANSI/NFPA 58-1989.
- 7) When the heater is to be stored indoors the propane cylinder must be disconnected from the heater and the cylinder moved away and stored in accordance with Chapter 5 of the above National Standard.

INSTALLATION USING NATURAL GAS APPLICATIONS

- 1) When installing the heater for use with natural gas, set the gas selector valve to the "Natural" position.
- 2) A regulator must be installed on the heater only if the line pressure to the heater is greater than 1/2 psi.
- 3) The installation of this heater to a natural gas supply must conform with all applicable local codes or, in the absence of local codes, with the National Fuel gas Code, ANSI Z223.1/NFPA 54.

COMMON INSTALLATION AND OPERATIONAL PROBLEMS

- 1) **LOW VOLTAGE AT THE HEATER**
This is one of the most common problems and is usually the result of the supply cord having too small a wire gauge for its length, or low voltage at the power source. Low voltage results in the motor overheating, burnt relay contacts, or a relay that will not make contact. Check supply voltage at heater.
- 2) **GAS SUPPLY LINE UNDERSIZED**
- 3) **INSUFFICIENT VAPORIZATION AT SUPPLY**
Normally caused by undersized supply tank.

- 3) **INSUFFICIENT VAPORIZATION AT SUPPLY**
Normally caused by undersized supply tank.
- 4) **IMPROPER GAS SUPPLY PRESSURE**
Usually a result of propane supply pressure being too high because of improper or lack of regulation or too low of natural gas pressure at meter.
- 5) **DIRTY GAS SUPPLY**
Dirty gas can cause strainers to plug or form a build-up in the burner orifice.
- 6) **LACK OF PREVENTIVE MAINTENANCE**
Heaters must be cleaned as required, especially when used in a dirty environment.
- 7) **IMPROPER SUPPLY OF FRESH AIR**
It is normally recommended that the intake air of the heater be taken from outside the enclosed area. This provides a slight pressurization and prevents any problems associated with re-circulation.

ON SITE SAFETY PROBLEMS & OPERATING INSTRUCTIONS

- 1) Set the **gas selector valve** for fuel being used. The conversion shall be done by the owner or lessor of the equipment.
NOTE: When using Propane Gas the Selector Valve **MUST** be locked in the "ON" position.
- 2) Ensure the **manual shut-off valve** (valve nearest the burner) is in the "ON" position.
- 3) Connect power supply (115 volt). Check voltmeter to confirm voltage (min 105 required).
- 4) Slowly open shut-off valve at gas meter or propane tank. Check for leaks.
- 5) Push **START** button
- 6) Set **thermostat** for desired room temperature.
- 7) To stop turn gas off.

The appliance area should be kept clear and free from combustible materials, gasoline, and other flammable vapors and liquids.

Ensure that the flow of supply air and combustion gases is not obstructed.

The installation and operation of this heater shall comply with the code requirements specified by the authorities having jurisdiction.

General criteria for the use of construction heaters may be found in the applicable sections of American National Standard A-10.10-1987, Safety Requirements for Temporary and Portable Space Heating Devices and Equipment Used in the construction industry.

THE INSTALLATION AND MAINTENANCE OF THE HEATER MUST BE ACCOMPLISHED BY A QUALIFIED SERVICE PERSON.

ON-SITE SAFETY PROBLEMS

1) SHORTING OUT OF DEFECTIVE COMPONENTS

This is a very common problem which saves short term expense at the risk of a large future cost. Any heaters found in this condition should be removed immediately.

2) IMPROPER ENCLOSURES

When heaters are installed partially to the outside for fresh air intake, strict adherence must be made to the minimum clearance to combustibles given on the instruction plate. Wood framing around a heater can cause a safety hazard.

3) SUPPLYING LIQUID PROPANE TO HEATER

This problem has occurred from time to time. To minimize the damage, shut off the gas supply and let the heater run until all of the liquid in the lines had been consumed.

PREVENTIVE MAINTENANCE

Sure Flame construction heaters are built to withstand the rigors of operating on construction sites, for mining applications, and a multitude of other locations where heaters are used. To maintain the reliable performance required it is necessary to do a certain amount of regular maintenance.

A) VISUAL CHECKS

The following items should be checked for excessive wear or damage:

- 1) Wheels (if installed)
- 2) Cords and Connectors
- 3) Wiring and Conduit
- 4) Heater shell (including heat shield) and control box

It is recommended that units purchased as spares be rotated periodically, so that each unit will be placed in operation at least once every 90 days.

B) BURNER

Flame rod and insulator - Clean with soap and water or solvent on a routine basis. Any build up on burner should also be removed at this time.

Spark Plug - Clean with solvent and check spark gap, approximately .070 to .085

C) CONTROL BOX

The inside of the control box should be cleaned using a dry cloth or by blowing compressed air. Do not use any liquid or aerosol spray cleaners. Also check that all electrical connections are snug and tight.

D) MOTOR

The electric motor on the S405 heater is fitted with sealed bearings and no oiling required. Keep the motor clean by blowing or wiping off dust or dirt in order to prevent the motor from over heating.

F) FAN

Check for dust or dirt build up on fan blades. Check the tightness of the set screws and run the heater to check for fan vibration.

TROUBLE SHOOTING

SEQUENCE	PROBLEM	CHECK	CAUSE
1.Press START - Power relay closes indicated by a "click" sound (adjust thermostat clockwise for S405 and S400T Off/On model only)	Relay does not close	-If no power between L1, L2 -If no power at limit switch -If no power at transformer -If no power at relay coil -If power at relay coil	-No power at plug -Faulty stop/start switch -Faulty limit switch -Faulty ignition control -Faulty Relay
Fan motors starts	Motor does not start	If no power between T1,T2 If power between T1, T2	-Faulty relay contacts -Faulty Motor
2.Ignition control produces spark	No spark	-If power between Power and GND on ignition control -If NO power between Power and GND on ignition control	-Faulty ignition control or spark plug -Faulty transformer
Short delay until fan reaches full RPM			
Air switch closes		-If NO power at air switch -If power at air switch	-Insufficient air pressure differential to close air switch or faulty air switch -Faulty solenoid
Safety shut-off gas valve open indicated by "click" sound	Valve does not open, no gas		
3. Gas ignites, flame is proven	No flame	-Recheck sequence #2	-Insufficient gas pressure -Check gas supply
4. Light ON		-Press STOP button to reset return to Sequence #1 above	

S405 Heater Parts

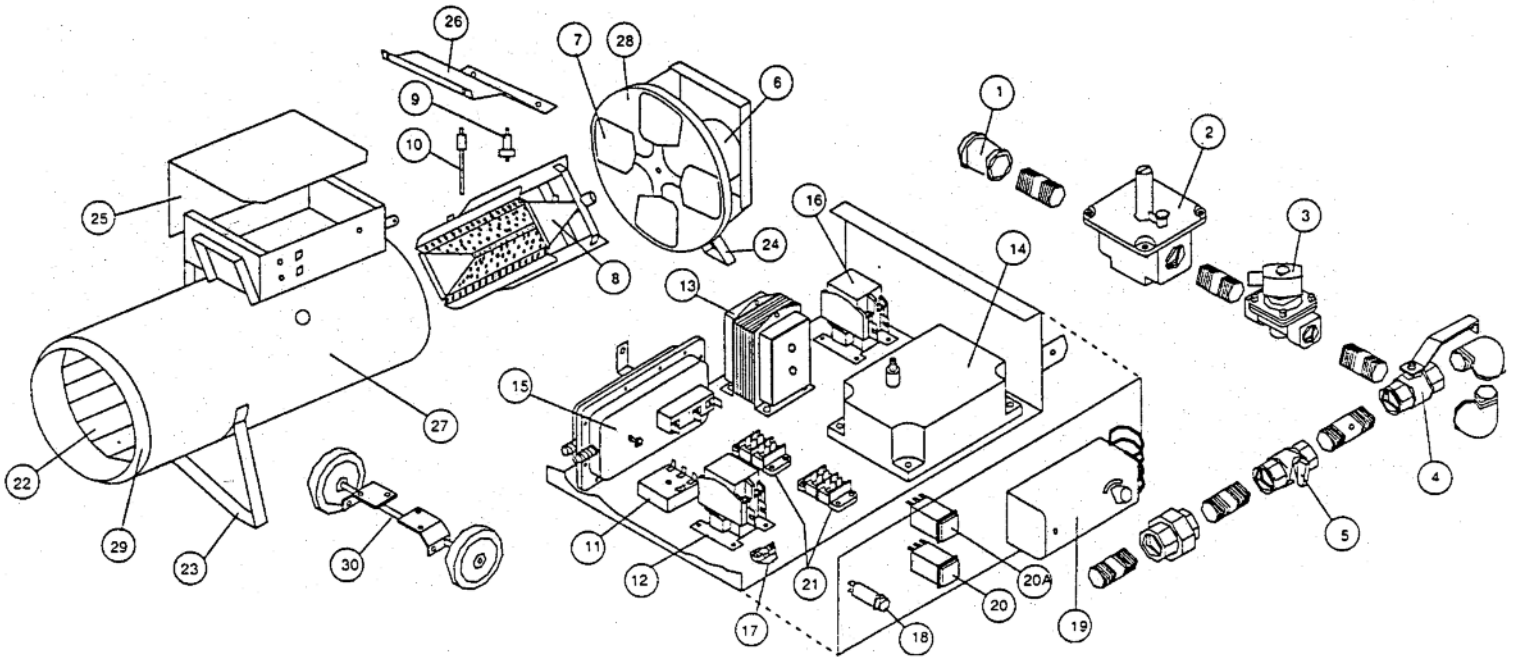

Ref.	Part No.	Description	Ref.	Part No.	Description
1	SFP 40SV01	Strainer (S400-80)	20A	SFP 3337G	On Switch (Green)
2	SFP 2524	Low Pressure Regulator	21	SFP 5768	Terminal Block
3	SFP 4514	Solenoid Shut Off Valve 24V	22	SFP S400-2	Heat Shield
4	SFP 40SV04	Gas Selector Valve (S400-73)	23	SFP S400-57	Front Leg Assembly
5	SFP 2538	Manual Shut Off Valve 3/4" valve	24	SFP S400-47	Rear Leg Assembly (less motor mount & screen)
6	SFP 2430	Motor 1/4 H.P.	25	SFP 4517	Control Box Lid
7	SFP 2420	Fan Blade	26	SFP SC400-38	Valve Train Cover
8	SFP 40SB26	Burner	27	SFP S400-53	Heater Body Includes 22, 23 & 29
9	SFP 2142	Spark Plug	28	SFP SFP3859	Motor Mount (with screen & rear legs)
10	SL11B86	Flame Rod	29	SFP S400-3	Nose Cone
11	SFP 7465	24VAC 5-Second Delay-ON-Break Timer	30	ACC-SWK1	Wheel Kit (Optional)
12	SFP 4519	Control Relay 24V	31	ACC-40SV06	Regulator (Optional)
13	SFP 4510	Transformer 24V			
14	SFP 5943	Direct Spark Ignition Control			
15	SFP 5124	Air Switch			
16	SFP 4519	Motor Relay 24V			
17	SFP 2446	Hi Limit Thermoswitch			
18	SFP 4518	Indicator Light 24V			
19	SFP 2453	Thermostat			
20	SFP 3337R	OFF Switch (Red)			

S405 CONSTRUCTION HEATER WIRING DIAGRAM

NOTE: This wiring diagram applies to heaters with serial #0001 through #2737

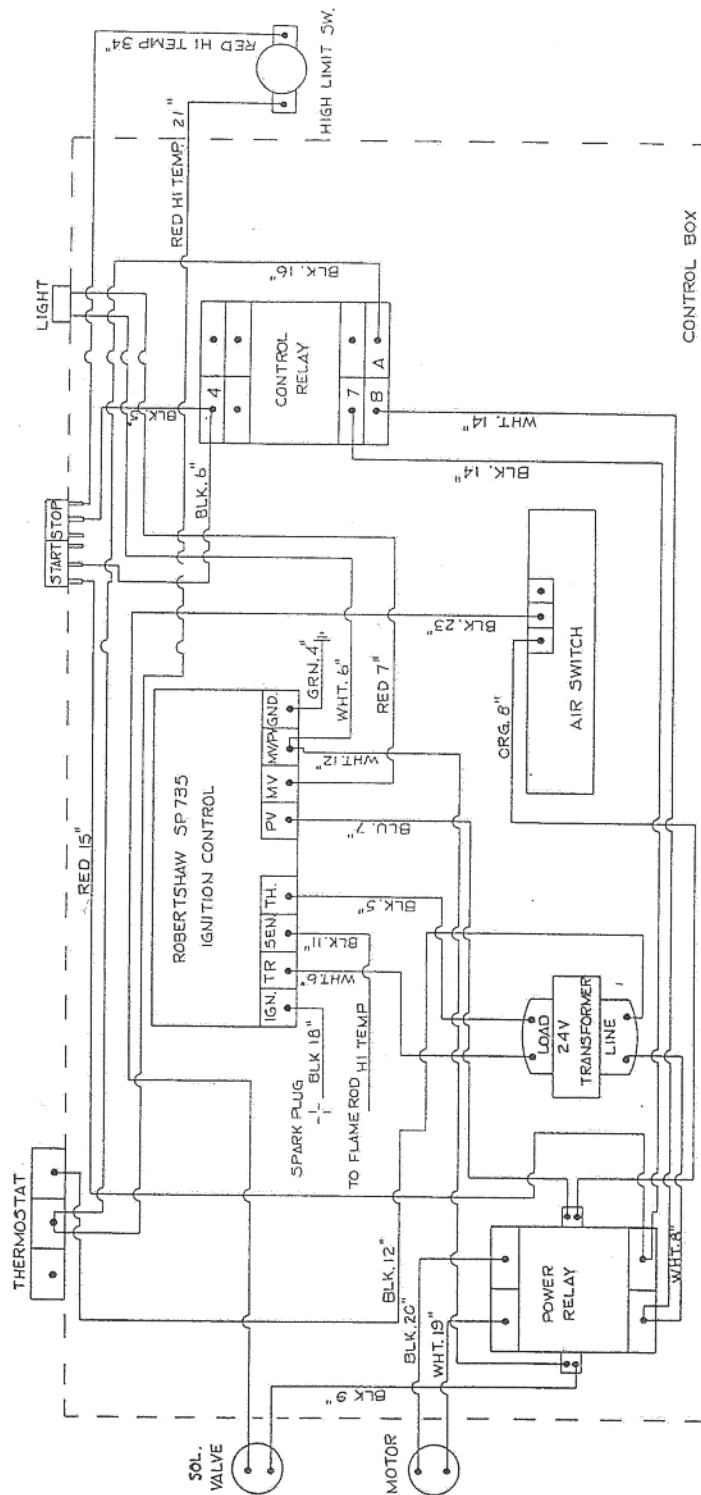

S405 CONSTRUCTION HEATER WIRING DIAGRAM

NOTE: This wiring diagram
applies to heaters with serial
#0001 through #2737

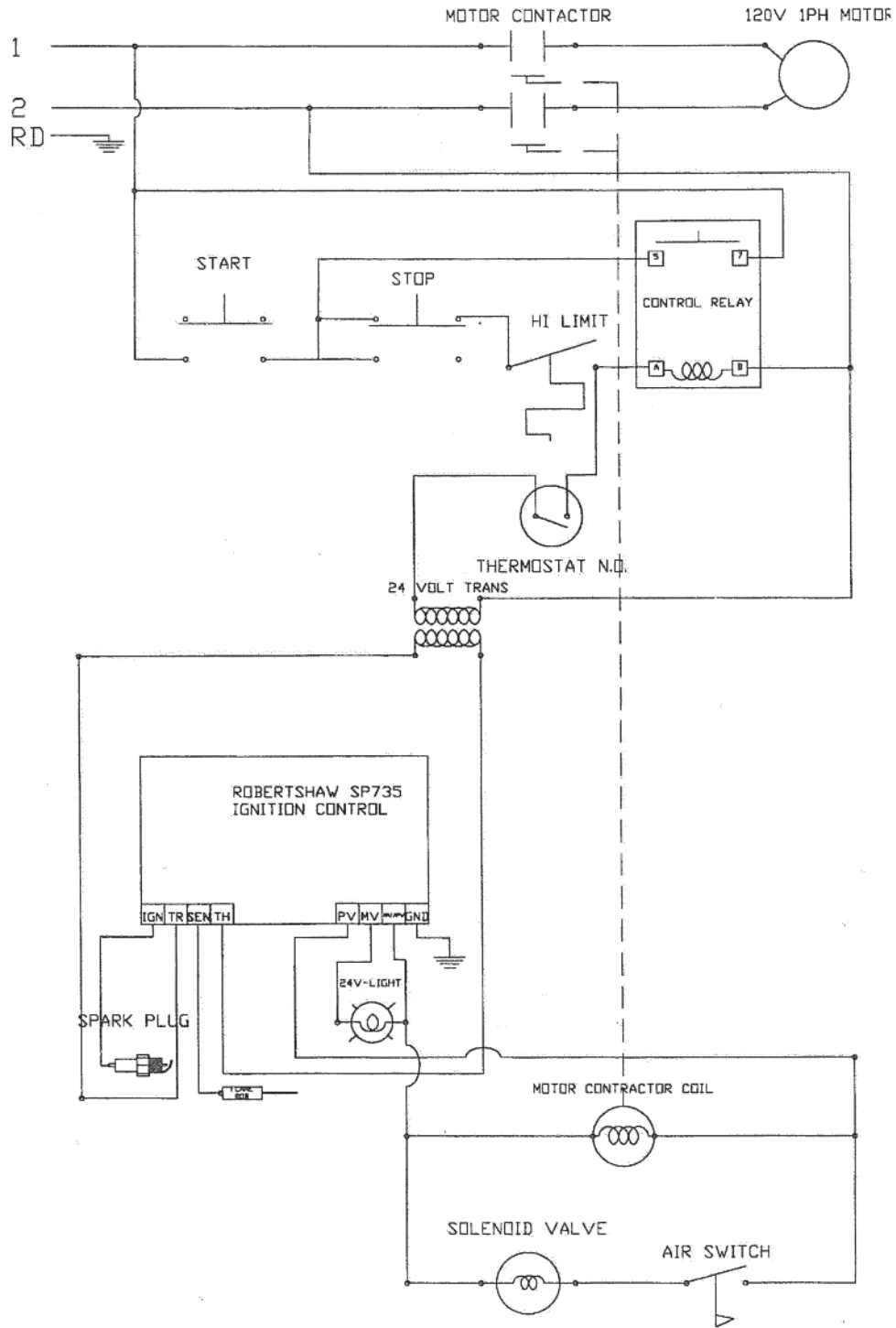

S405 CONSTRUCTION HEATER WIRING DIAGRAM

NOTE: This wiring diagram applies to heaters with serial #2738 and greater

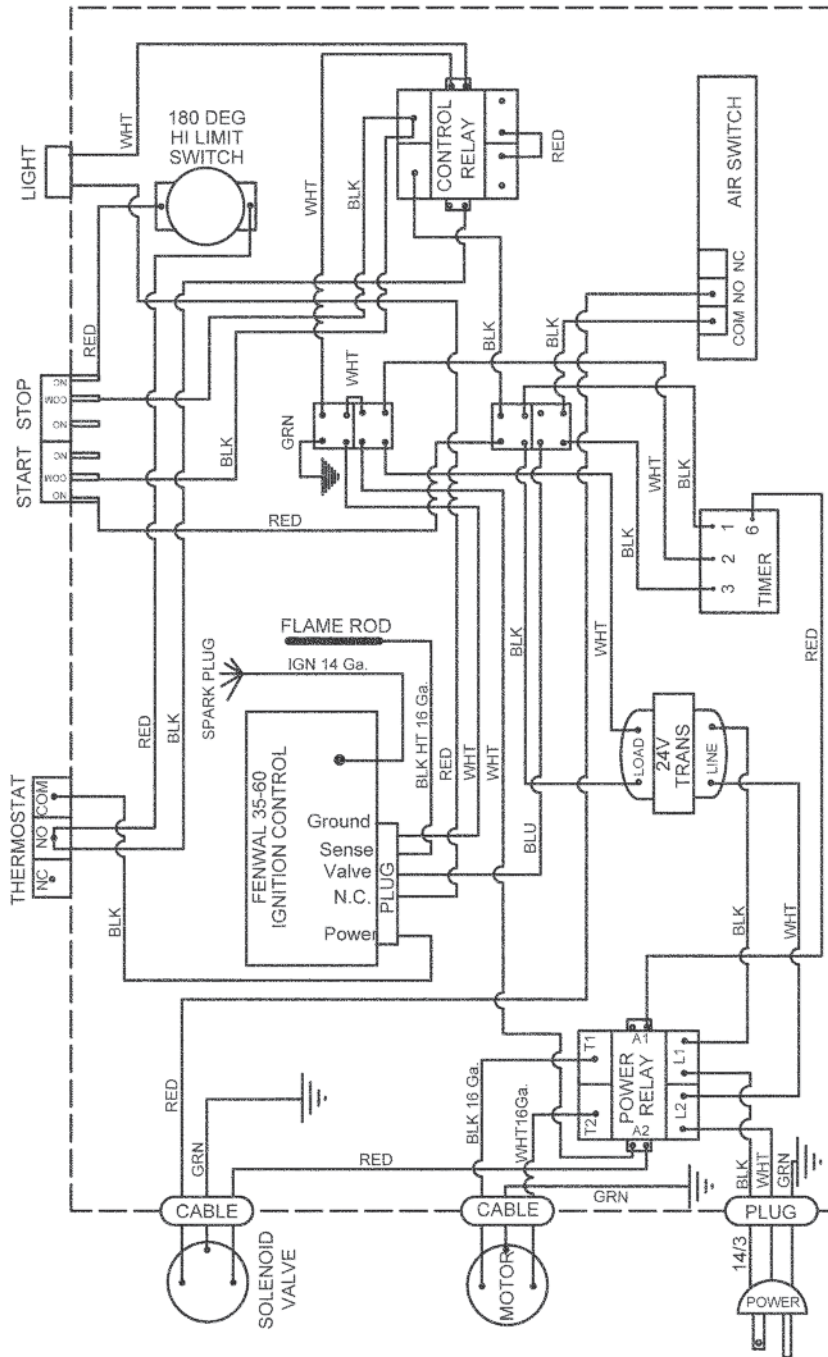

S405 CONSTRUCTION HEATER WIRING DIAGRAM

NOTE: This wiring diagram applies to heaters with serial #2738 and greater

