





# Safgard™

## Model 270SV

### High Water Limit

### 120 VAC Operating Voltage

-  Automatically interrupts pump or feeder when water contacts probe
-  Provides contacts for optional alarm
-  Ideal for boilers, receiver tanks and process applications.
-  Low maintenance — no moving parts to wear, stick or hang-up
-  Heavy-duty electro-mechanical design for long life



**WARNING:** To prevent electrical shock or equipment damage, power must be off during installation or servicing of the control. To prevent serious burns, the boiler should be thoroughly cooled before installing or servicing control. Only qualified personnel may install or service the control in accordance with local codes and ordinances. Read instructions completely before proceeding.

## 1. Where To Install

### BOILER OR TANK INSTALLATION

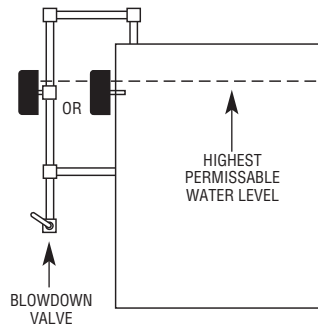

The 3/4" NPT probe must be installed at a location just below the highest permissible water level. The probe may be installed in any metal tank, boiler, or equalizing line. When installed in an equalizing line, a proper blowdown valve should be installed for regular maintenance.

**IMPORTANT:** To assure proper drainage, pipe diameter should be no less than 1" on installations in vertical piping.

## 2. Probe Installation

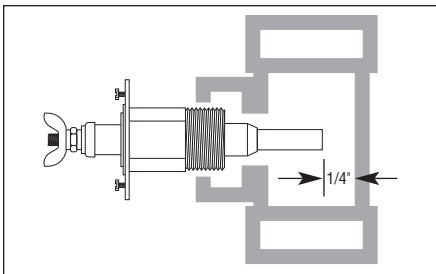

Check to insure 1/4" clearance from the probe to any surface inside the boiler, tank or tee. Apply pipe sealing compound to threads.

**Note:** Use of Teflon tape is not recommended.

## 3. Control Mounting

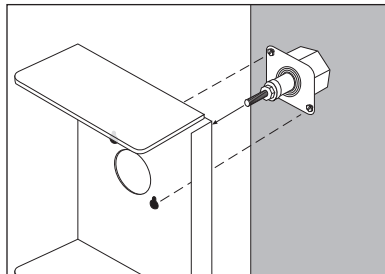

Remove the control cover and slide key-hole slots over probe mounting screws and tighten screws (with either a 1/4" hex head driver or flat screwdriver).

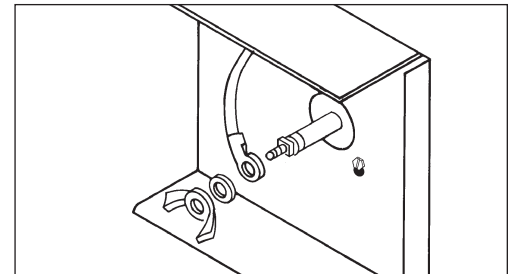

Connect the ring terminal wire lead to the probe terminal stud and secure with the lock washer and wing nut provided. *With the power removed*, proceed with installation and wiring described on next page.

## LIMITED MANUFACTURER'S WARRANTY

We warrant products manufactured by Hydrolevel Company to be free from defects in material and workmanship for a period of two years from the date of manufacture or one year from the date of installation, whichever occurs first. In the event of any claim under this warranty or otherwise with respect to our products which is made within such period, we will, at our option, repair or replace such products or refund the purchase price paid to us by you for such products. In no event shall Hydrolevel Company be liable for any other loss or damage, whether direct, indirect, incidental or consequential. This warranty is your **EXCLUSIVE** remedy and shall be **IN PLACE OF** any other warranty or guarantee, express or implied, including, without limitation, any warranty of **MERCHANTABILITY** or fitness for a particular purpose. This warranty may not be assigned or transferred and any unauthorized transfer or assignment thereof shall be void and of no force or effect.

## Dimensions

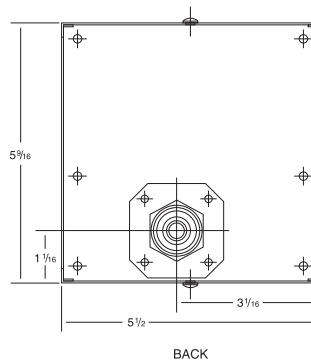

BACK

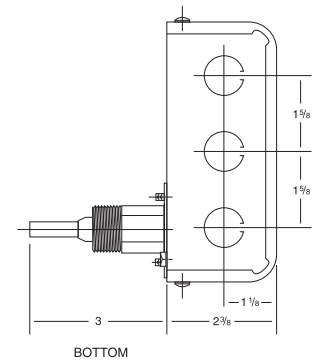

BOTTOM

## 4. Wiring

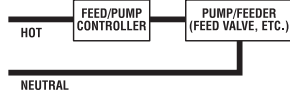

### TYPICAL WATER FEED CONTROL CIRCUIT

The Safgard 270SV High Limit wires in series with the system's water feed circuit.

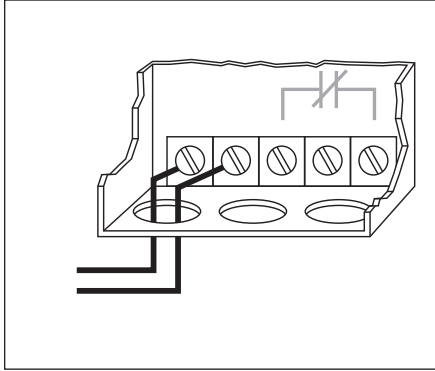

#### STEP 1

Connect the hot lead of input voltage (120 VAC, 60 Hz) to terminal **H** and the neutral lead to terminal **GN**.

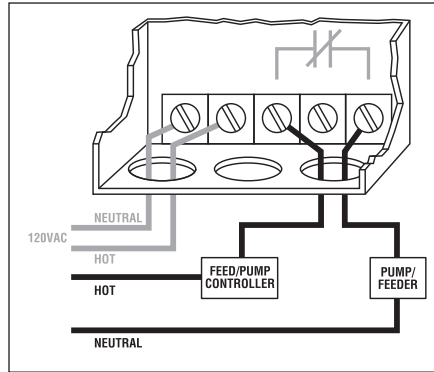

#### STEP 2

Connect the Feed/Pump Controller to terminal **C**. Connect the Pump/Feeder to terminal **NC**. When water reaches the High Limit, contacts C-NC will open, interrupting power to the Pump/Feeder. **Important:** If the current of the Pump/Feeder exceeds 15 amps, a suitable relay/starter should be installed.

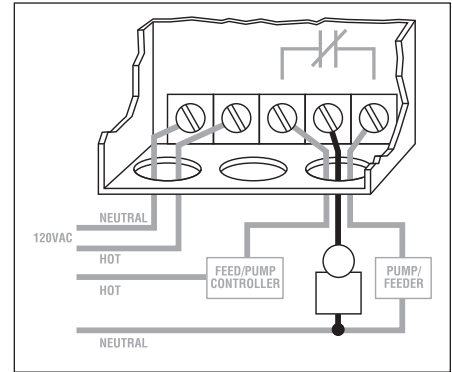

#### STEP 3

##### Optional High Water Alarm

Select an alarm with the same operating voltage as the Pump/Feeder. Connect the hot lead of the alarm to terminal **NO**. Connect the neutral lead to the Feed circuit neutral. When water reaches the High Limit, contact C-NO will close, powering the alarm.

## MAINTENANCE

Remove and inspect probe annually. Clean any sediment or scale from the probe using a scouring pad or steel wool.

## TROUBLE SHOOTING

### IF THE PUMP DOES NOT OPERATE

1. Using a voltage meter, isolate the problem to determine if the 270SV High Limit Control is breaking the circuit.
2. Check to insure that the water level is below the probe and that the tee is not collecting water which could be sensed by the probe.
3. Remove power and recheck wiring.
4. Remove power and check for adequate clearance from the probe to any surface inside the boiler or tee.

### IF THE PUMP DOES NOT SHUT DOWN WHEN WATER REACHES THE HIGH LIMIT

1. Make sure that the high water level is in contact with the probe.
2. Ensure that the probe lead wire is fastened securely.
3. Check for proper ground between the probe and the boiler shell or tee. Excessive use of Teflon tape or sealing compound may insulate the probe from ground.
4. Recheck wiring and test for correct incoming voltage.

## Specifications

**MAXIMUM PRESSURE:** 250 PSI  
**INPUT VOLTAGE:** 120 VAC, 60 HZ  
**SWITCH RATINGS:** .25 hp @ 120 VAC  
**RESISTIVE LOAD:** 20 A  
**SWITCH CONTACTS:** SPDT

# HYDROLEVEL COMPANY

P.O. Box 1847  
New Haven, CT 06508  
Phone: (203) 776-0473  
FAX: (203) 773-1019