



**COMMERCIAL GROUP**

# MN-36

**ONE COMPARTMENT  
GOVERNMENT-TYPE SCULLERY  
IN ACCORDANCE with WW-P-541b**

**SUBMITTAL DATA**

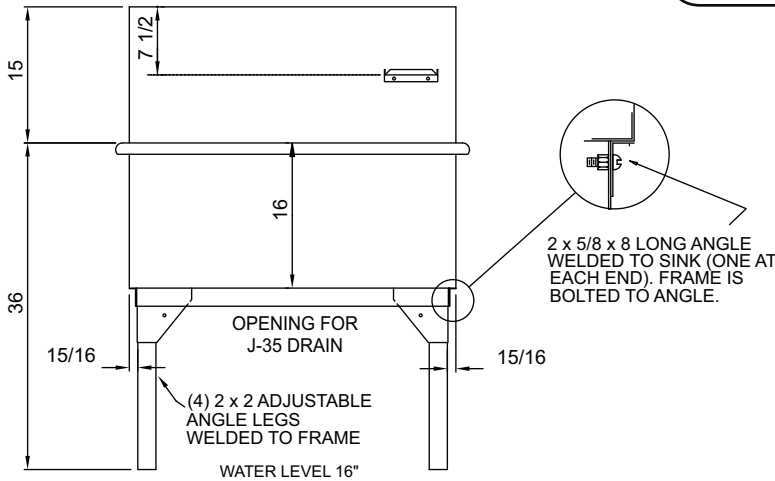
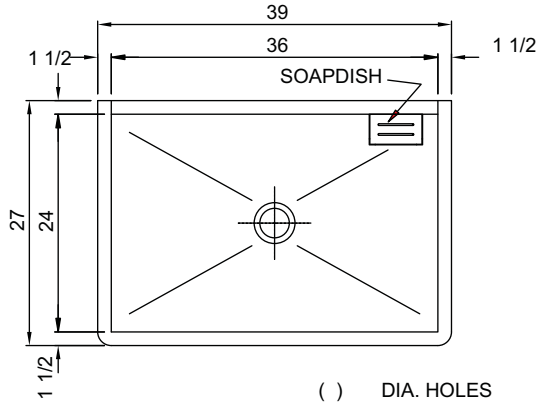

**To be specified:**

- Faucet hole punching:
  - (1) Hole Centered
  - (2) Holes on 8" centers
  - (3) Holes on 4" centers
- Alternate Punching:
  - Faucet Model: \_\_\_\_\_

Punching required: \_\_\_\_\_

**SPECIFICATION**

Constructed of 14 gauge type 304, 18-8 stainless steel. Front and rear horizontal radius inside compartment 11/16". Vertical corners of compartment are square. Bottoms pitched to drain. Interior surfaces polished with a non-porous Hand-Blended Just Finish. Exposed exterior surfaces to have a brush finish. Supported on (4) 2" x 2" x 14 ga. stainless steel angle legs with angle frame and leveling bolts. In accordance with Federal Specification WW-P-541B, dated August 1, 1980. Drain punch #35 centered for Just J-35 unless otherwise specified.

FUNCTIONAL DESIGN, QUALITY, AND SPECIFICATIONS LISTED DESCRIBE THE JUST STANDARD OF QUALITY. WHEN MAKING COMPARISONS WITH OTHER OFFERINGS, INSIST ON THE JUST QUALITY OF CONSTRUCTION. FOR ADDITIONAL INFORMATION REGARDING THE COMPLETE LINE OF JUST SINKS, FAUCETS AND DRAINS, VISIT OUR WEB SITE AT [www.justmfg.com](http://www.justmfg.com)

Job Name \_\_\_\_\_

Customer \_\_\_\_\_

Architect/Engineer \_\_\_\_\_

APPROVED FOR MANUFACTURING

MODEL NO. MN-36 QTY. \_\_\_\_\_

COMPANY \_\_\_\_\_

TITLE \_\_\_\_\_ DATE \_\_\_\_\_

SIGNATURE \_\_\_\_\_

**JUST MANUFACTURING COMPANY**

9233 KING STREET . FRANKLIN PARK . ILLINOIS . 60131-2111

PH: 847-678-5150 . FAX: 847-678-6817 . E-MAIL: [custserv@justmfg.com](mailto:custserv@justmfg.com) . [www.justmfg.com](http://www.justmfg.com)