



No.:

Date: 17-DEC-2012

Customer :

TECHNICAL PROPOSAL

Three-phase induction motor - Squirrel cage rotor

Product line : W22 NEMA Premium - Ball Bearings

Catalog Number : 30009ET3G449T-W22

List Price : \$70,362

Notes:

Performed by:

Checked:



No.:

Date: 17-DEC-2012

## DATA SHEET

### Three-phase induction motor - Squirrel cage rotor

Customer :  
Product line : W22 NEMA Premium - Ball Bearings

Frame : L447/9T  
Output : 300 HP  
Frequency : 60 Hz  
Poles : 8  
Full load speed : 890  
Slip : 1.11 %  
Voltage : 460 V  
Rated current : 371 A  
Locked rotor current : 2340 A  
Locked rotor current (I<sub>L</sub>/I<sub>n</sub>) : 6.3  
No-load current : 170 A  
Full load torque : 1746 lb.ft  
Locked rotor torque : 220 %  
Breakdown torque : 240 %  
Design : B  
Insulation class : F  
Temperature rise : 105 K  
Locked rotor time : 16 s (hot)  
Service factor : 1.15  
Duty cycle : S1  
Ambient temperature : -20°C - +40°C  
Altitude : 1000  
Degree of Protection : IP55  
Approximate weight : 3704 lb  
Moment of inertia : 284.94 sq.ft.lb  
Noise level : 64 dB(A)

	D.E.	N.D.E.	Load	Power factor	Efficiency (%)
Bearings	6322 C3	6319 C3	100%	0.78	95.4
Regreasing interval	20000 h	20000 h	75%	0.73	95.4
Grease amount	60 g	45 g	50%	0.62	95.4

Notes:

Performed by

Checked



No.:

Date: 17-DEC-2012

### PERFORMANCE CURVES RELATED TO RATED OUTPUT

Three-phase induction motor - Squirrel cage rotor

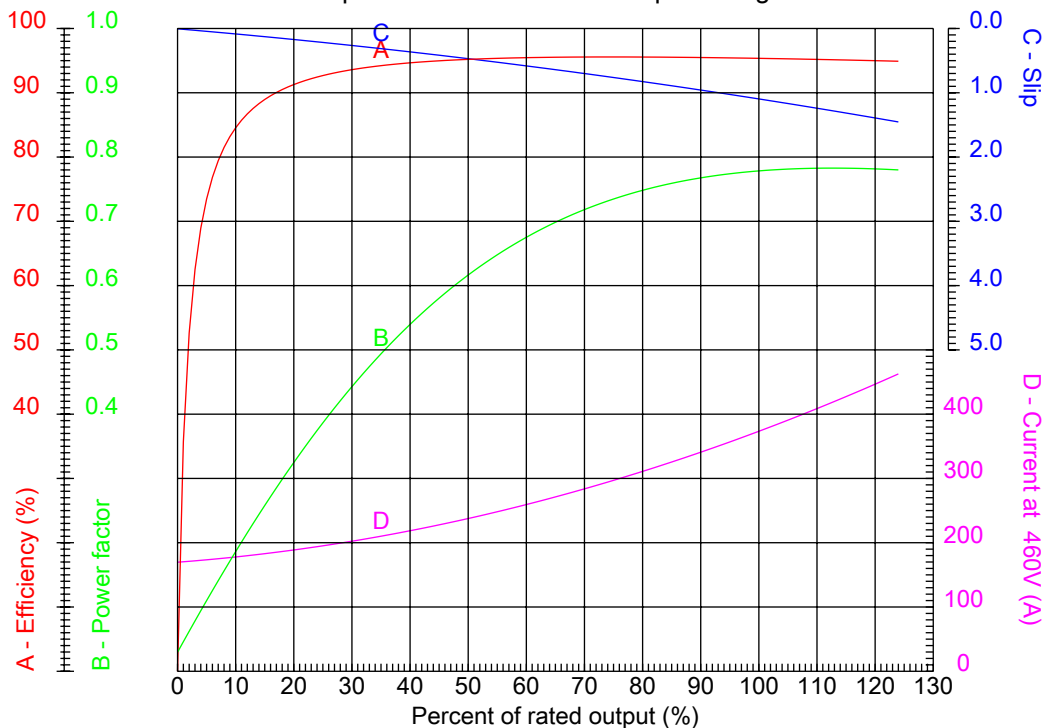

Customer :  
Product line : W22 NEMA Premium - Ball Bearings

Frame : L447/9T	Locked rotor current (I <sub>l</sub> /I <sub>n</sub> ) : 6.3
Output : 300 HP	Duty cycle : S1
Frequency : 60 Hz	Service factor : 1.15
Full load speed : 890	Design : B
Voltage : 460 V	Locked rotor torque : 220 %
Rated current : 371 A	Breakdown torque : 240 %
Insulation class : F	

Notes:

Performed by

Checked



No.:

Date: 17-DEC-2012

### CHARACTERISTIC CURVES RELATED TO SPEED Three-phase induction motor - Squirrel cage rotor

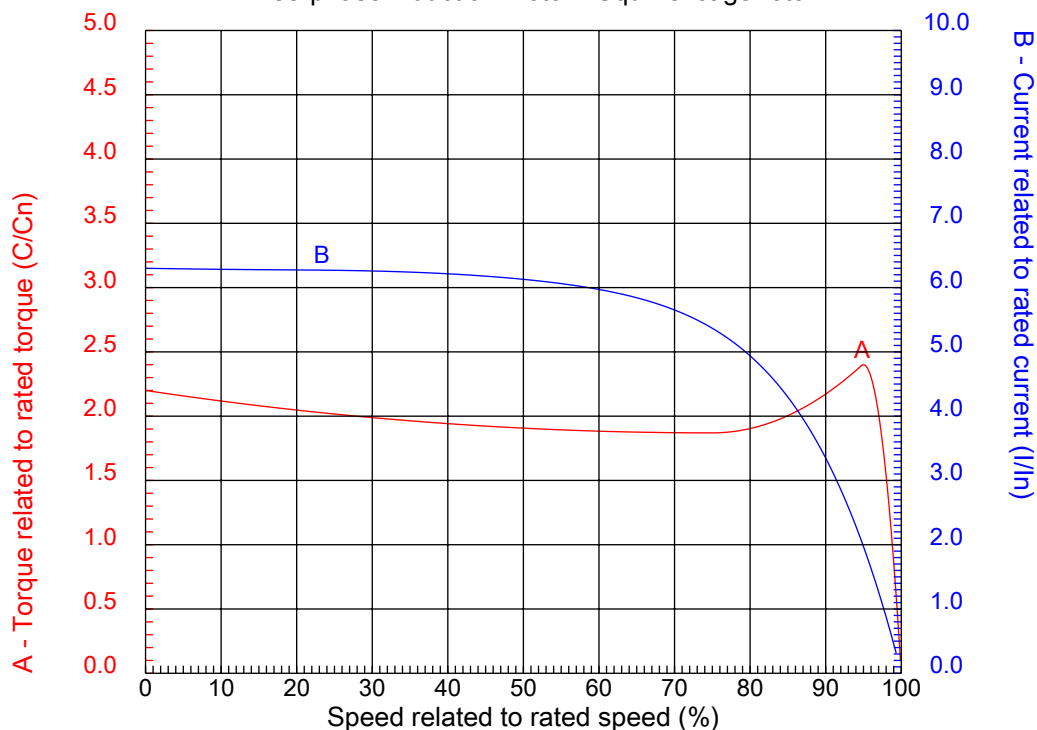

Customer :  
Product line : W22 NEMA Premium - Ball Bearings

Frame	: L447/9T	Locked rotor current (I <sub>l</sub> /I <sub>n</sub> )	: 6.3
Output	: 300 HP	Duty cycle	: S1
Frequency	: 60 Hz	Service factor	: 1.15
Full load speed	: 890	Design	: B
Voltage	: 460 V	Locked rotor torque	: 220 %
Rated current	: 371 A	Breakdown torque	: 240 %
Insulation class	: F		

Notes:

Performed by

Checked

1 2 3 4 5 6 7 8

A

B

C

D

E

F

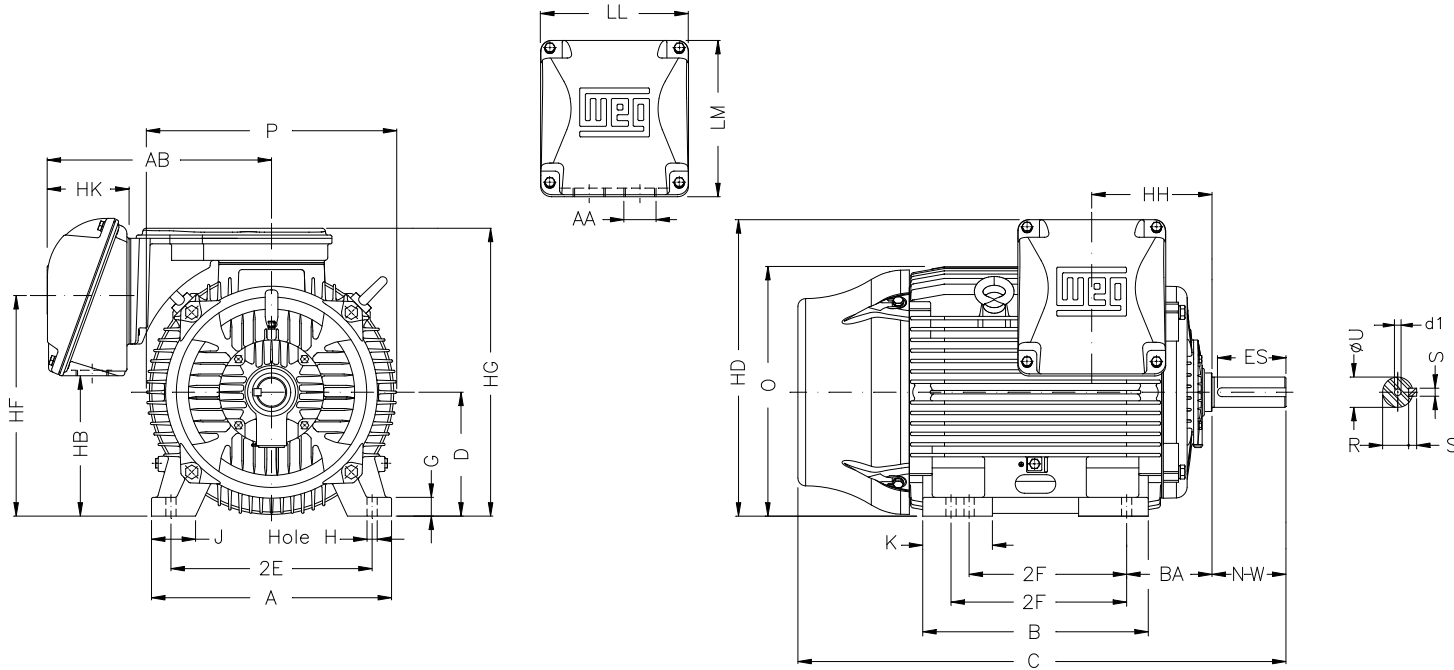

Notes:	
Performed by:	
Checked:	
Customer:	
W22 NEMA Premium - Ball Bearings	
Three-phase induction motor Frame L447/9T - IP55	17-DEC-2012

2E 18.000	J 3.937	A 21.929	P 25.866	AB 23.071
2F 20.000/25.000	K 8.780	B 31.535	BA 7.500	U 3.375
N-W 8.500	ES 7.087	S 0.875	R 2.880	depth 0.875
D 11.000	G 1.630	HB 11.417	O 23.874	T 4.83
HF 20.551	HG 28.236	HH 11.500	HK 8.464	H 0.810
C 57.181	LL 15.906	LM 17.244	AA 2XNPT 3"	d1 DUNC 3/4"-10
d2 DUNC 3/4"-10	Flange FD-508	AJ 20.000	AK 18.000	BD 21.65
BF 0.828	BB 0.203			

