



No.:

Date: 17-DEC-2012

Customer :

TECHNICAL PROPOSAL

Three-phase induction motor - Squirrel cage rotor

Product line : W22 NEMA Premium - Ball Bearings

Catalog Number : 30036ET3G449TS-W22

List Price : \$38,269

Notes:

Performed by:

Checked:



No.:

Date: 17-DEC-2012

DATA SHEET

Three-phase induction motor - Squirrel cage rotor

Customer :
Product line : W22 NEMA Premium - Ball Bearings

Frame : 447/9TS
Output : 300 HP
Frequency : 60 Hz
Poles : 2
Full load speed : 3570
Slip : 0.83 %
Voltage : 460 V
Rated current : 320 A
Locked rotor current : 2240 A
Locked rotor current (I_L/I_n) : 7.0
No-load current : 65.0 A
Full load torque : 435 lb.ft
Locked rotor torque : 250 %
Breakdown torque : 240 %
Design : B
Insulation class : F
Temperature rise : 80 K
Locked rotor time : 14 s (hot)
Service factor : 1.15
Duty cycle : S1
Ambient temperature : -20°C - +40°C
Altitude : 1000
Degree of Protection : IP55
Approximate weight : 2545 lb
Moment of inertia : 58.080 sq.ft.lb
Noise level : ---

	D.E.	N.D.E.	Load	Power factor	Efficiency (%)
Bearings	6314 C3	6314 C3	100%	0.90	95.8
Regreasing interval	4000 h	4000 h	75%	0.89	95.8
Grease amount	27 g	27 g	50%	0.86	95.4

Notes:

Performed by

Checked



No.:

Date: 17-DEC-2012

PERFORMANCE CURVES RELATED TO RATED OUTPUT

Three-phase induction motor - Squirrel cage rotor

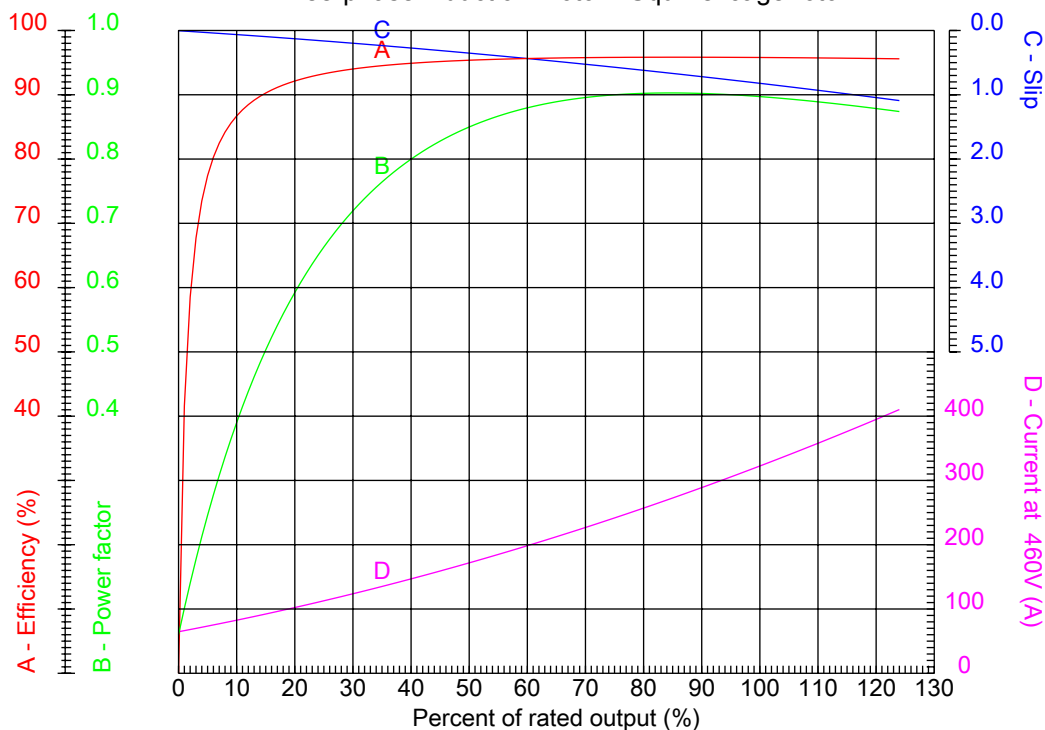

Customer :
Product line : W22 NEMA Premium - Ball Bearings

Frame : 447/9TS	Locked rotor current (I _l /I _n) : 7.0
Output : 300 HP	Duty cycle : S1
Frequency : 60 Hz	Service factor : 1.15
Full load speed : 3570	Design : B
Voltage : 460 V	Locked rotor torque : 250 %
Rated current : 320 A	Breakdown torque : 240 %
Insulation class : F	

Notes:

Performed by

Checked



No.:

Date: 17-DEC-2012

CHARACTERISTIC CURVES RELATED TO SPEED Three-phase induction motor - Squirrel cage rotor

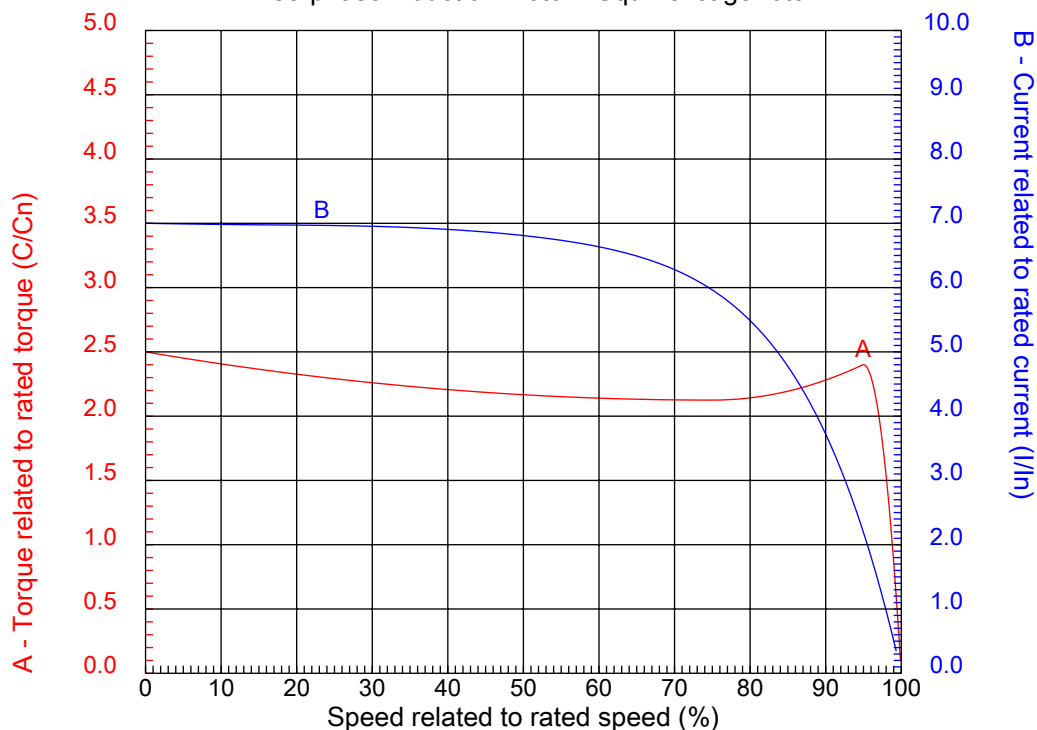

Customer :
Product line : W22 NEMA Premium - Ball Bearings

Frame	: 447/9TS	Locked rotor current (I _l /I _n)	: 7.0
Output	: 300 HP	Duty cycle	: S1
Frequency	: 60 Hz	Service factor	: 1.15
Full load speed	: 3570	Design	: B
Voltage	: 460 V	Locked rotor torque	: 250 %
Rated current	: 320 A	Breakdown torque	: 240 %
Insulation class	: F		

Notes:

Performed by

Checked

1 2 3 4 5 6 7 8

A

B

C

D

E

F

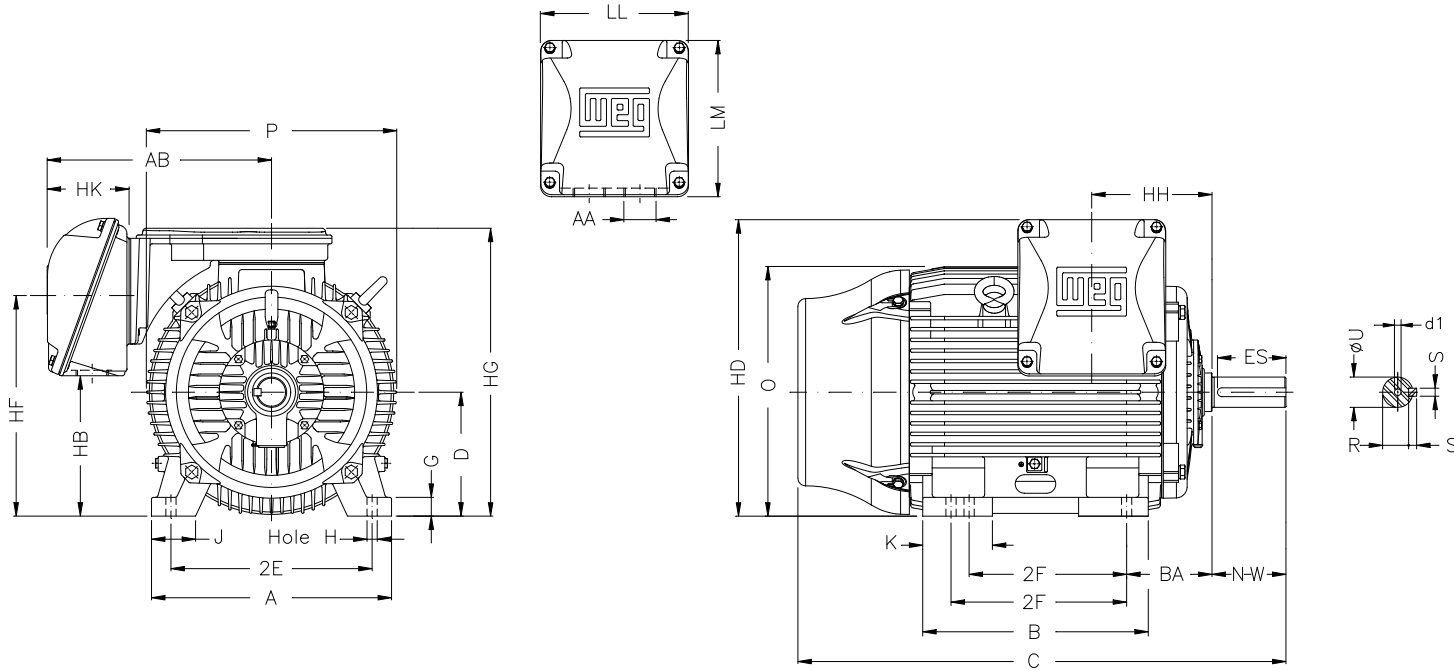

Notes:

Performed by:

Checked:

Customer:

W22 NEMA Premium - Ball Bearings

Three-phase induction motor
Frame 447/9TS - IP55

17-DEC-2012



2E 18.000	J 3.937	A 21.929	P 23.583	AB 20.670
2F 20.000/25.000	K 11.77	B 31.535	BA 7.500	U 2.375
N-W 4.750	ES 3.000	S 0.625	R 2.021	depth 0.625
D 11.000	G 1.630	HB 12.598	O 22.795	T 7.378
HF 20.724	HG 26.850	HH 11.803	HK 6.968	H 0.810
C 52.588	LL 14.646	LM 15.040	AA 2XNPT 3"	d1 DUNC 3/4"-10
d2 DUNC 3/4"-10	Flange FD-508	AJ 20.000	AK 18.000	BD 21.65
BF 0.828	BB 0.203			