

# ASSEMBLY INSTRUCTIONS

---

## Corner Desk

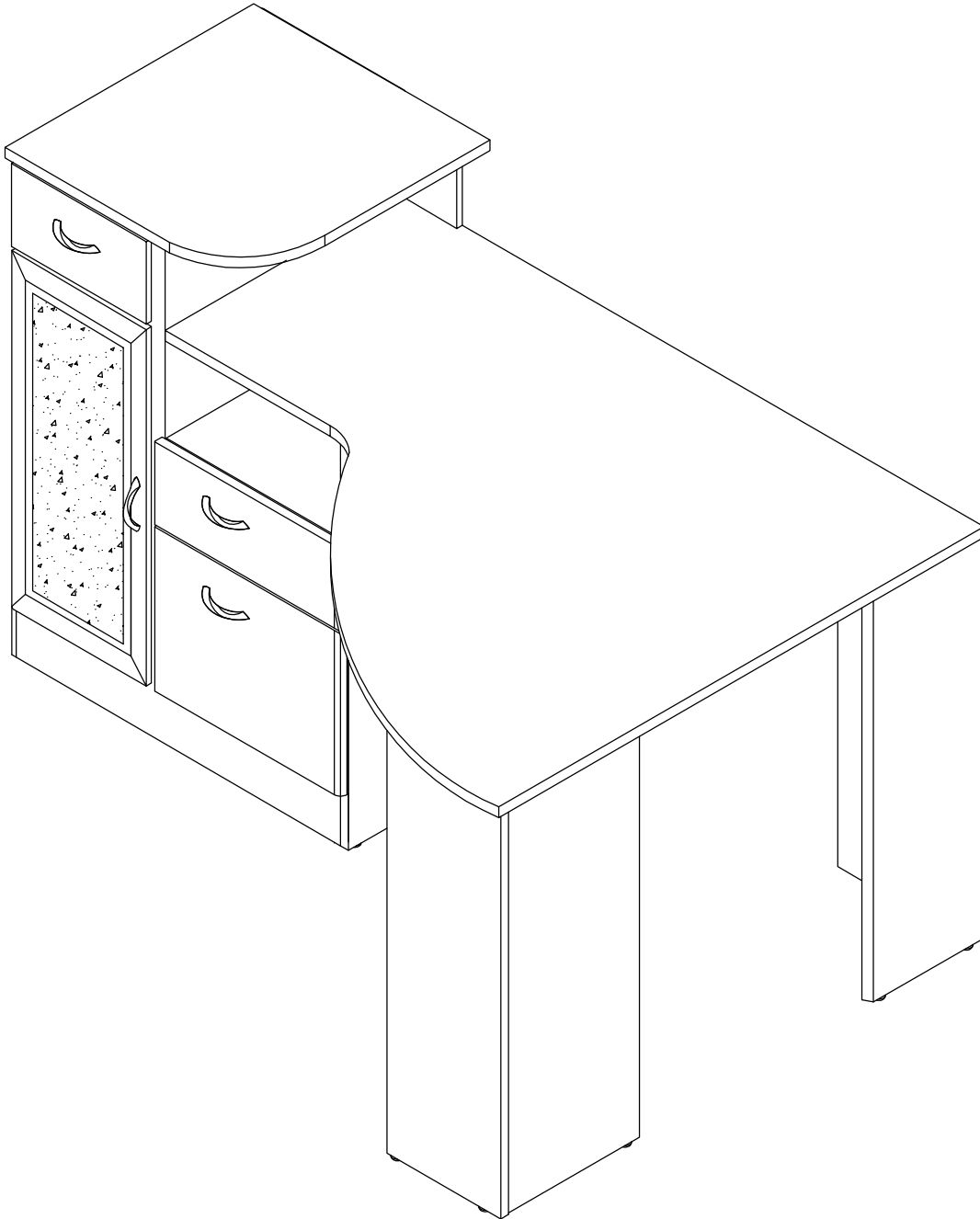

NEED HELP?  
Call 1-800-950-4782  
[www.bushfurniture.com](http://www.bushfurniture.com)

Lot Code #

---

Part Number A174577B

Keep manual for future reference.

# Bush<sup>®</sup>

## FURNITURE

**Thank you for purchasing** this Bush Furniture product. We trust that you will be completely satisfied with your product for many years to come. Bush Furniture products are backed by a 1-year warranty and crafted with today's styles in mind for the way you work. **Do not return product to store — contact us first at 1-800-950-4782.**

**Merci d'avoir acheté** ce produit Bush Furniture. Nous sommes sûr que vous serez complètement satisfait de votre meuble pendant de nombreuses années. Les produits Bush Furniture sont garantis pendant 1 ans et sont conçus dans les styles actuels tout en gardant à l'esprit votre façon de travailler. **Ne renvoyez pas le produit au magasin, contactez-nous d'abord au 1-800-950-4782.**

**Gracias por comprar** este producto de Bush Furniture. Confiamos que usted estará completamente satisfecho con su mueble por muchos años. Los productos de Bush Furniture tienen 1 años de garantía y son diseñados con los estilos de hoy en mente para la manera que usted vive. **No devuelva el producto a la tienda, primero comuníquese con nosotros al 1-800-950-4782.**

## CONTACT US

Monday – Friday  
8:30 a.m. – 7:30 p.m. ET  
(Except Holidays)

Bush Consumer Services  
One Mason Drive, P.O. Box 460  
Jamestown, NY 14701  
ConsumerService@Bushindustries.com

**1-800-950-4782 USA/CANADA**  
**001-800-950-4782 MEXICO**

Se habla español  
Outside USA/CANADA/MEXICO  
001-716-665-2510 Ext. 4514

## IT'S AS EASY AS 1,2,3

### Assembly tips:

1. Read the instructions and become familiar with the parts.
2. Ensure this carton contains all parts, fasteners and hardware.
3. To protect floors, assemble the furniture on the carton.
4. An assistant may be helpful.
5. Use of power tools is not recommended.

### Conseils d'assemblage:

1. Lisez les instructions et familiarisez-vous avec les pièces.
2. Assurez-vous que le carton contient toutes les pièces, toutes les pièces de fixation et toute la quincaillerie.
3. Pour protéger vos sols, assemblez le meuble sur le carton.
4. Il peut être utile de vous faire aider.
5. L'utilisation d'outils électriques n'est pas recommandée.

### Consejos de Ensamblaje:

1. Lea las instrucciones y familiarícese con las partes.
2. Asegúrese de que esta caja contenga todas las piezas, los sujetadores y el equipo.
3. Para proteger el piso, ensamble el mueble en el carton.
4. Un asistente puede serle útil.
5. El uso de herramientas eléctricas no se recomienda.



## CONSUMER SERVICE

### YOU CAN DEPEND ON

**Questions?** Operators are standing by at our TOLL-FREE help line to assist you with assembly; and, if necessary, to quickly replace damaged/missing parts. Assistance is available 5 days a week. Simply have your store receipt, instruction manual, and part number/description ready when you call our TOLL-FREE help line. It's that easy.

UN SERVICE CLIENTELE SUR LEQUEL VOUS POUVEZ COMPTER

**Des questions?** Des opérateurs sont prêts sur notre ligne d'assistance GRATUITE pour vous aider à l'assemblage et, si nécessaire, remplacer rapidement les pièces endommagées/manquantes. L'assistance est disponible 5 jours par semaine. Ayez simplement votre reçu de magasin, votre manuel d'instruction et le numéro de pièces/description à votre disposition lorsque vous appelez notre ligne d'assistance GRATUITE. C'est aussi simple que ça.

SERVICIO AL CONSUMIDOR CON EL QUE PUEDE CONTAR

**¿Preguntas?** Los operadores están listos para ayudarlo con el ensamblaje a través de una línea de ayuda GRATUITA, y en caso de ser necesario, reemplazar de inmediato las piezas dañadas o faltantes. La asistencia está disponible los 5 días de la semana. Solamente tenga listos su recibo de compra, manual de indicaciones y número/descripción de la pieza al momento de llamarnos a la línea de ayuda GRATUITA. Es así de sencillo.

[www.bushfurniture.com](http://www.bushfurniture.com)



## WARNING

**THIS PRODUCT IS DESIGNED AND INTENDED FOR USE WITH COMPUTER, FAX, AND PRINTER EQUIPMENT ONLY. IMPROPER LOADING WITH TELEVISION OR OTHER HEAVY EQUIPMENT COULD CAUSE INSTABILITY, TIP OVER, AND/OR SERIOUS INJURY.**

**ESTE PRODUCTO ESTA DISEÑADO SOLAMENTE PARA EL USO CON COMPUTADORS, FAXES, E IMPRESORAS. INAPROPIADO USO AL PONER TELEVISORES U OTRO EQUIPO PESADO PUEDE CAUSAR INESTABILIDAD, RODAMIENTO, Y/O HERIDA (GOLPES) SERIOS.**

**CE PRODUIT EST UNIQUEMENT CONÇU POUR UNE UTILISATION AVEC UN ORDINATEUR, UN TÉLÉCOPIEUR, OU UNE IMPRIMANTE. UN CHARGEMENT INCORRECT AVEC UNE TÉLÉVISION OU AUTRE MATÉRIEL LOURD PEUT LE RENDRE INSTABLE OU LE RENVERSER, ET PEUT VOUS CAUSER DES ENDOMMAGEMENTS SÉRIEUX.**



## CAUTION



**RISK OF BREAKING GLASS. HANDLE GLASS CAREFULLY DURING ASSEMBLY. USE EYE AND HAND PROTECTION. IMPROPER HANDLING CAN RESULT IN CUTS OR LACERATIONS.**

**RIESGO DE ROMPER EL VIDRIO. MANEJE EL VIDRIO CON CUIDADO AL ENSAMBLAR ESTA UNIDAD. USE PROTECCIÓN PARA SUS OJOS Y SUS MANOS. EL MANEJO INAPROPIADO DEL VIDRIO PUEDE CAUSARLE CORTADURAS O LACERACIONES.**

**RISQUE DE BRIS DE VERRE. FAITES ATTENTION LORS DE LA MANIPULATION DU VERRE PENDANT L'ASSEMBLAGE. UTILISEZ DES PROTECTIONS POUR LES YEUX ET LES MAINS. UNE MAUVAISE MANIPULATION PEUT PROVOQUER DES COUPURES OU DES LACÉRATIONS.**

**WARNING**

DO NOT LOAD UNIT WITHOUT PROPERLY ATTACHING BACK PANEL. DOING SO COULD CAUSE INSTABILITY, PRODUCT COLLAPSE, AND/OR SERIOUS INJURY.

---

NO CARGUE ESTA UNIDAD SIN EL PANEL DE ATRÁS. HACERLO PUEDE CAUSAR INESTABILIDAD, QUE EL PRODUCTO SE DERRUMBE, Y/O HERIDAS (GOLPES) SERIAS.

---

NE PAS CHARGER LE PRODUIT SANS ATTACHER CORRECTEMENT LE PANNEAU ARRIÈRE. FAIRE AINSI PEUT CAUSER L'INSTABILITÉ OU L'EFFONDREMENT DU PRODUIT ET PEUT VOUS CAUSER DES ENDOMMAGEMENTS SÉRIEUX.

**WARNING**

REMOVE ALL ITEMS FROM SHELVES BEFORE MOVING OR LIFTING.

---

RETIRE TODOS LOS ARTÍCULOS DE LOS ESTANTES ANTES DE MOVER O LEVANTAR OBJETOS.

---

RETIREZ TOUS LES ÉLÉMENTS ÉTAGÈRES AVANT DE SE DÉPLACER OU DE LEVAGE

***NOTICE (STEP 19)***

THIS COMPARTMENT IS INTENDED TO HOLD COMPUTER EQUIPMENT. THE DOOR MUST BE KEPT OPEN WHEN EQUIPMENT IS OPERATED. FAILURE TO DO SO COULD RESTRICT AIRFLOW AND MAY RESULT IN EQUIPMENT OVERHEATING.

EL COMPARTIMIENTO ESTÁ DISEÑADO PARA ACOMODAR UN COMPUTADOR. LA PUERTA DEBE MANTENERSE ABIERTA MIENTRAS EL EQUIPO ES OPERADO. EL NO MANTENER LA PUERTA ABIERTA DURANTE LA OPERACIÓN PUEDE RESTRINGIR EL FLUJO DE AIRE Y RESULTAR EN EL COMPUTADOR CALENTARSE DEMASIADO.

CE COMPARTIMENT EST PRÉVU POUR TENIR LE MATÉRIEL INFORMATIQUE. LA PORTE DOIT ÊTRE MAINTENUE OUVERTE TANDIS QUE LE MATÉRIEL EST UTILISÉ. LE MANQUE DE FAIRE AINSI A PU LIMITER LA CIRCULATION D'AIR ET PEUT AVOIR COMME CONSÉQUENCE LA SURCHAUFFE DU MATÉRIEL.

C162912

MAXIMUM WEIGHT: 200 LBS (90.9KG)  
PESO MÁXIMO: 200 LIBRAS (90.9KILOGRAMO)  
POIDS MAXIMUM: 200 LIVRES (90.9 KILOGRAMME)

MAXIMUM WEIGHT: 50 LBS (22.7KG)  
PESO MÁXIMO: 50 LIBRAS (22.7KILOGRAMO)  
POIDS MAXIMUM: 50 LIVRES (22.7 KILOGRAMME)

MAXIMUM WEIGHT: 13 LBS (5.9KG)  
PESO MÁXIMO: 13 LIBRAS (5.9KILOGRAMO)  
POIDS MAXIMUM: 13 LIVRES (5.9 KILOGRAMME)

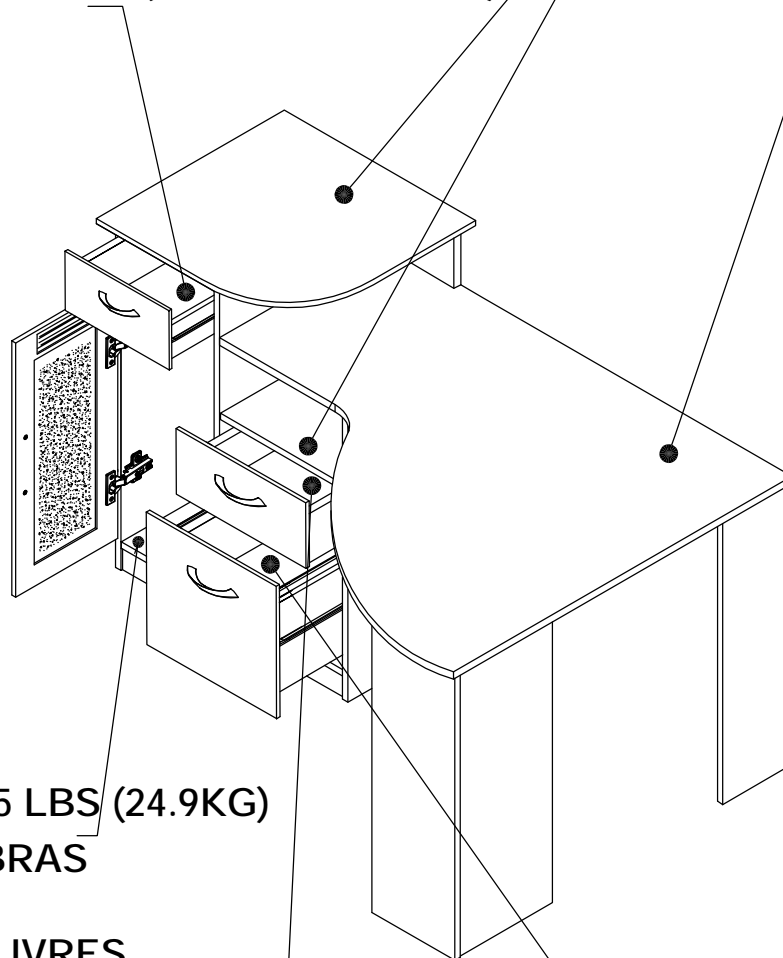

MAXIMUM WEIGHT: 55 LBS (24.9KG)  
PESO MÁXIMO: 55 LIBRAS  
(24.9KILOGRAMO)  
POIDS MAXIMUM: 55 LIVRES  
(24.9 KILOGRAMME)

MAXIMUM WEIGHT: 15 LBS (6.8KG)  
PESO MÁXIMO: 15 LIBRAS (6.8KILOGRAMO)  
POIDS MAXIMUM: 15 LIVRES (6.8 KILOGRAMME)

MAXIMUM WEIGHT: 35 LBS (15.8KG)  
PESO MÁXIMO: 35 LIBRAS (15.8KILOGRAMO)  
POIDS MAXIMUM: 35 LIVRES (15.8 KILOGRAMME)

**MODEL**    **HM66315A**  
**HM66615A**  
**HM66915A**  
**HM66115A**

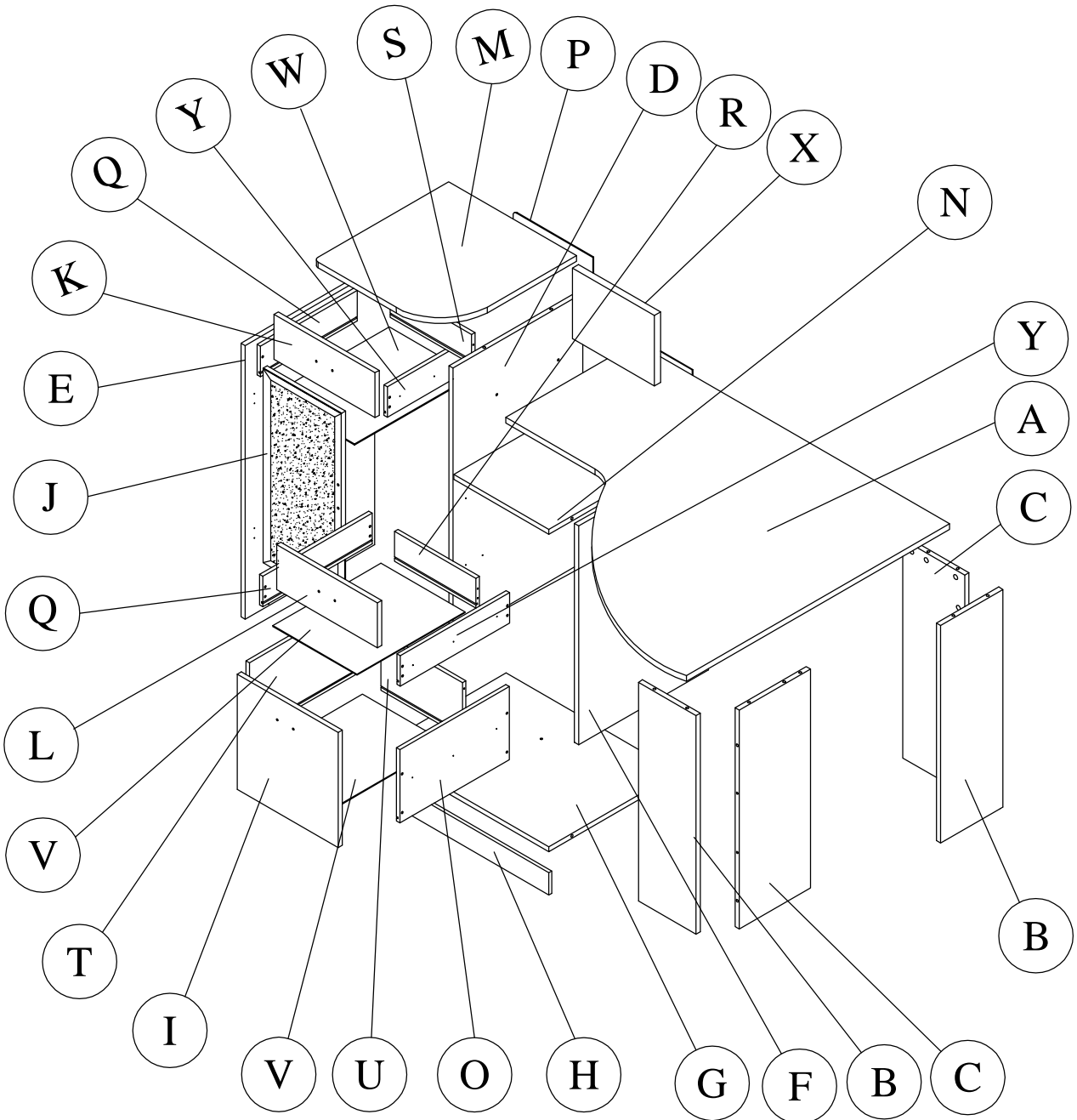
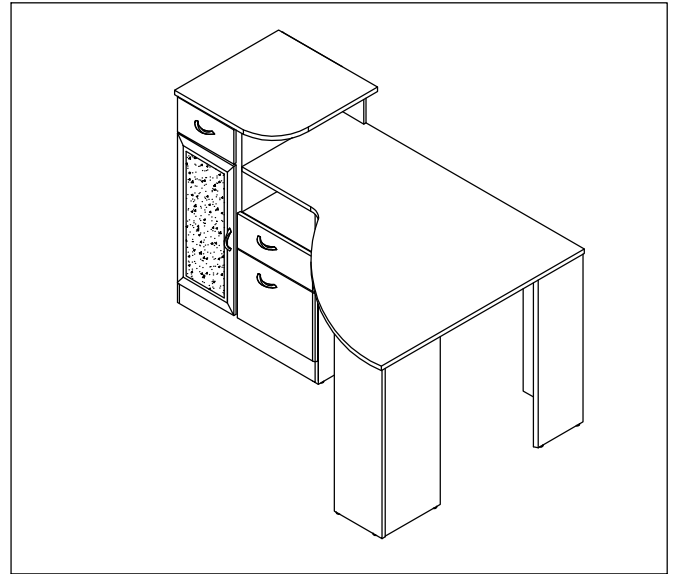

**HM66315A**

A [1] W152996	J [1] S152901	S [1] W159055
B [2] W157846	K [1] W159108	T [1] W180519
C [2] W152997	L [1] W159109	U [1] W159057
D [1] W181088	M [1] W152904	V [2] W159058
E [1] W180515	N [1] W181090	W [1] W159059
F [1] W181089	O [1] W180517	X [1] W159896
G [1] W136471	P [1] W136479	Y [2] W180520
H [1] W136472	Q [2] W180518	
I [1] W159107	R [1] W159054	

**HM66615A**

A [1] W159090	J [1] S159099	S [1] W159065
B [2] W159091	K [1] W159100	T [1] W180526
C [2] W159092	L [1] W159101	U [1] W159067
D [1] W181091	M [1] W159102	V [2] W159068
E [1] W180522	N [1] W181093	W [1] W159069
F [1] W181092	O [1] W180524	X [1] W159897
G [1] W159096	P [1] W159105	Y [2] W180527
H [1] W159097	Q [2] W180525	
I [1] W159098	R [1] W159064	

**HM66915A**

A [1] W152933	J [1] S152942	S [1] W159075
B [2] W157848	K [1] W159111	T [1] W180533
C [2] W152935	L [1] W159112	U [1] W159077
D [1] W181094	M [1] W152945	V [2] W159078
E [1] W180529	N [1] W181096	W [1] W159079
F [1] W181095	O [1] W180531	X [1] W159898
G [1] W152939	P [1] W152948	Y [2] W180534
H [1] W152940	Q [2] W180532	
I [1] W159110	R [1] W159074	



**HM66115A**

A [1] W170304  
B [2] W170305  
C [2] W170306  
D [1] W181097  
E [1] W180536  
F [1] W181098  
G [1] W170310  
H [1] W170311  
I [1] W170312

J [1] S170313  
K [1] W170314  
L [1] W170315  
M [1] W170316  
N [1] W181099  
O [1] W180538  
P [1] W170319  
Q [2] W180539  
R [1] W170321

S [1] W170322  
T [1] W180540  
U [1] W170324  
V [2] W170325  
W [1] W170326  
X [1] W170327  
Y [2] W180541

Fasteners are shown in actual size.

Los fijadores son demostrados en su tamaño actual.

Les attaches sont montrées dans l'échelle grandeur.

H159917

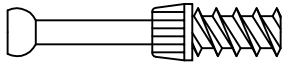
Quantity  
**28**

KD Bolt

H159916

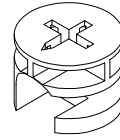
Quantity  
**28**

KD Cam

H124395

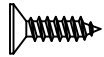
Quantity  
**40**

#6 x 1/2"

H156854

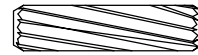
Quantity  
**4**

Wood Dowel 6 x 25mm

H160125

Quantity  
**12**

#10 x 1-1/2"

H152964

Quantity  
**8**

# 6 x 1 "

H27310

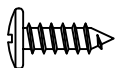
Quantity  
**10**

# 8 x 1/2"

H34174

Quantity  
**35**

# 3 x 3/4"

H35251

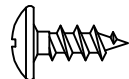
Quantity  
**8**

# 10 x 1/2"

H101725

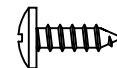
Quantity  
**12**

#6 x1/2"

H156849

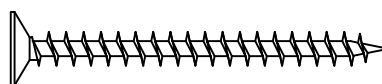
Quantity  
**8**

#10 x 2"

H100444

Quantity  
4



Drawer Bracket

H100446

Quantity  
2

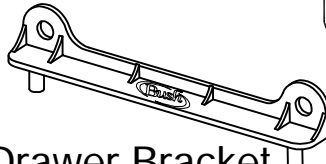

Drawer Bracket

H137197

Quantity  
5

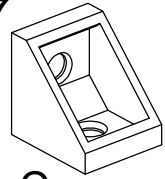

Plastic Connector

H154711

Quantity  
4

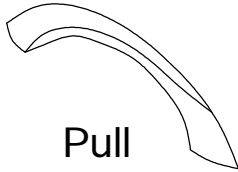

Pull

H136463

Quantity  
2

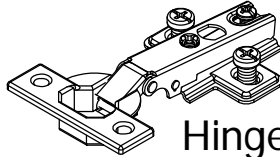

Hinge

H156859

Quantity  
2

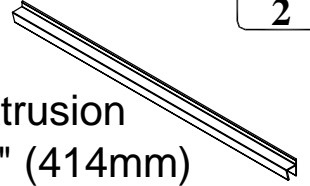

File Extrusion  
16-1/4" (414mm)

Z89898

Quantity  
3



16" Slide (406mm)

Z89899

Quantity  
3

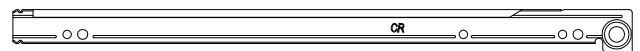

16" Slide (406mm)

Z89900

Quantity  
3



16" Slide (406mm)

Z89901

Quantity  
3



16" Slide (406mm)

H20385

Quantity  
10



Tack Glide

H27145

Quantity  
1

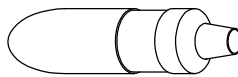

Glue

### HM66315A

H159895

Quantity  
**18**

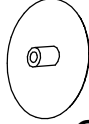

Cover Cap

### HM66915A

H73621

Quantity  
**18**

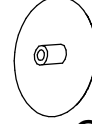

Cover Cap

### HM66615A

H95137

Quantity  
**18**

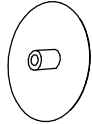

Cover Cap

### HM66115A

H170033

Quantity  
**18**

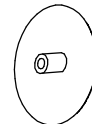

Cover Cap

Common assembly techniques.  
Técnica común de ensamblaje.  
Techniques communes d'assemblage.

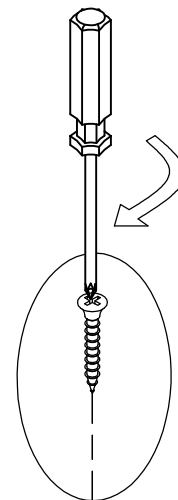
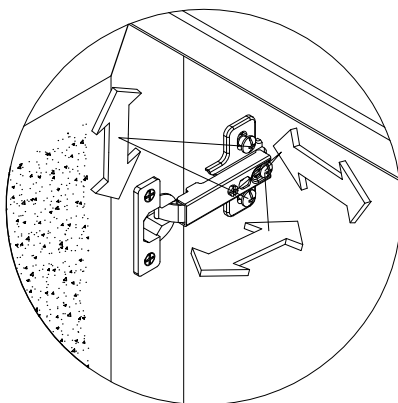
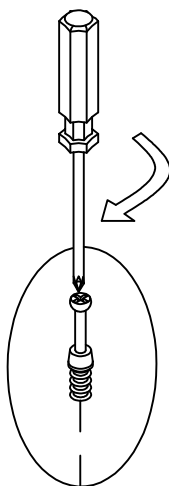
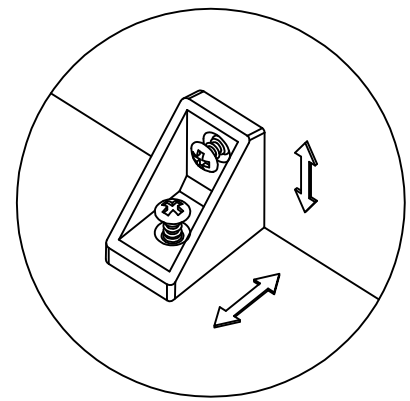
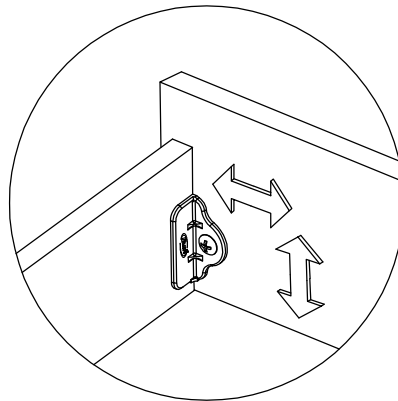
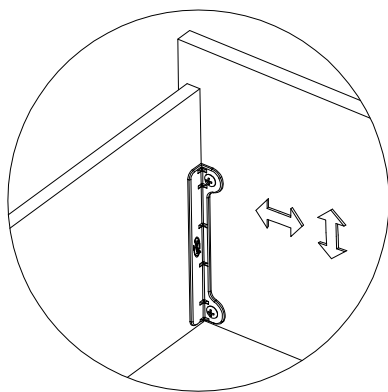
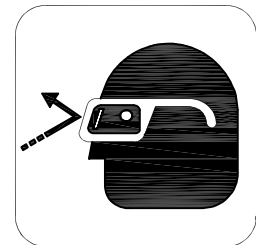
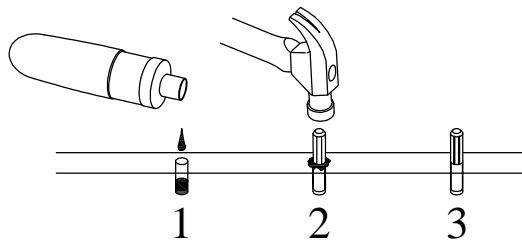
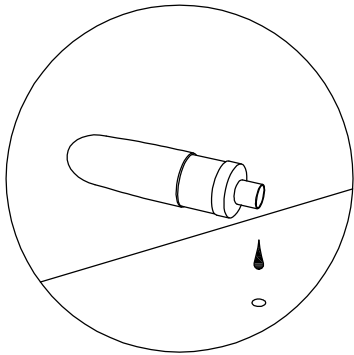
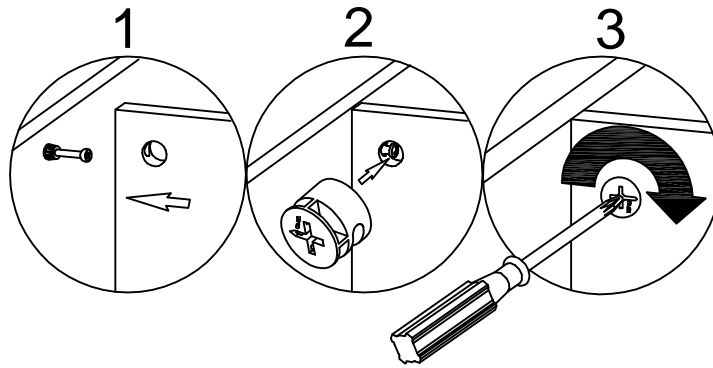

H159917

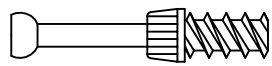

KD Bolt

[ 2 ]

H136463

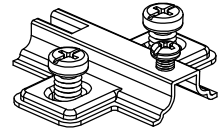

Hinge

[ 2 ]

Z89898

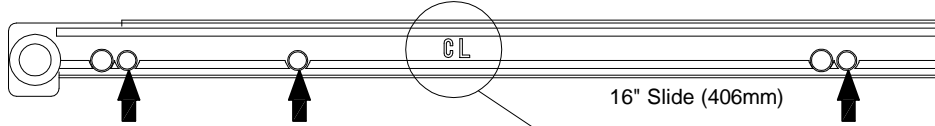

16" Slide (406mm)

[ 1 ]

H124395



#6 x 1/2"

[ 3 ]

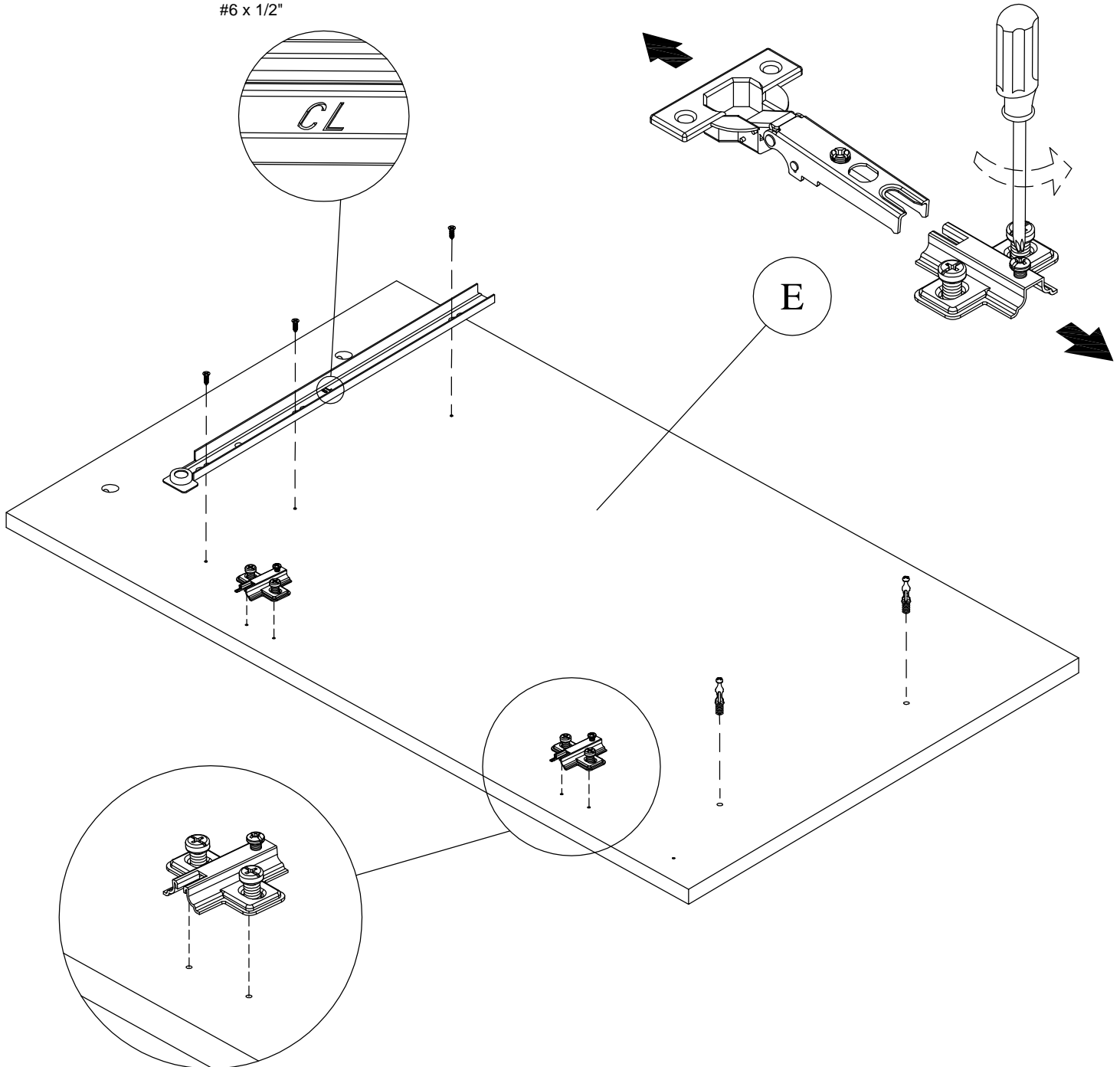

Z89898

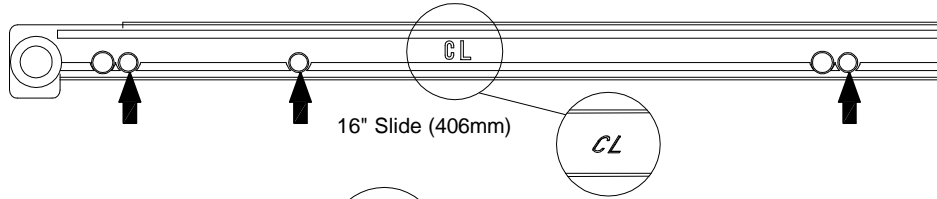

[ 2 ]

Z89899

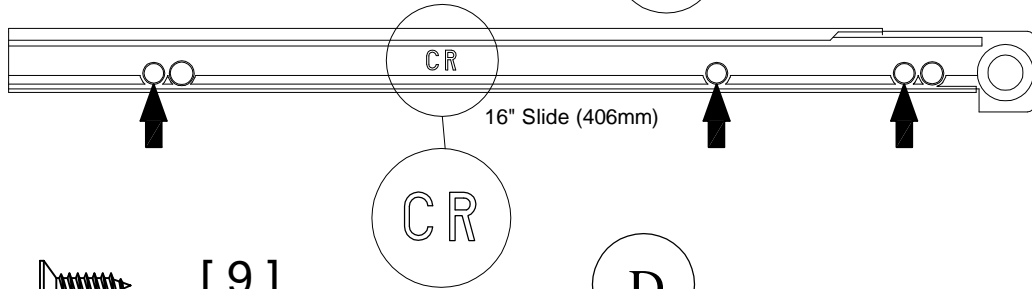

[ 1 ]

H124395



[ 9 ]

#6 x 1/2"

D

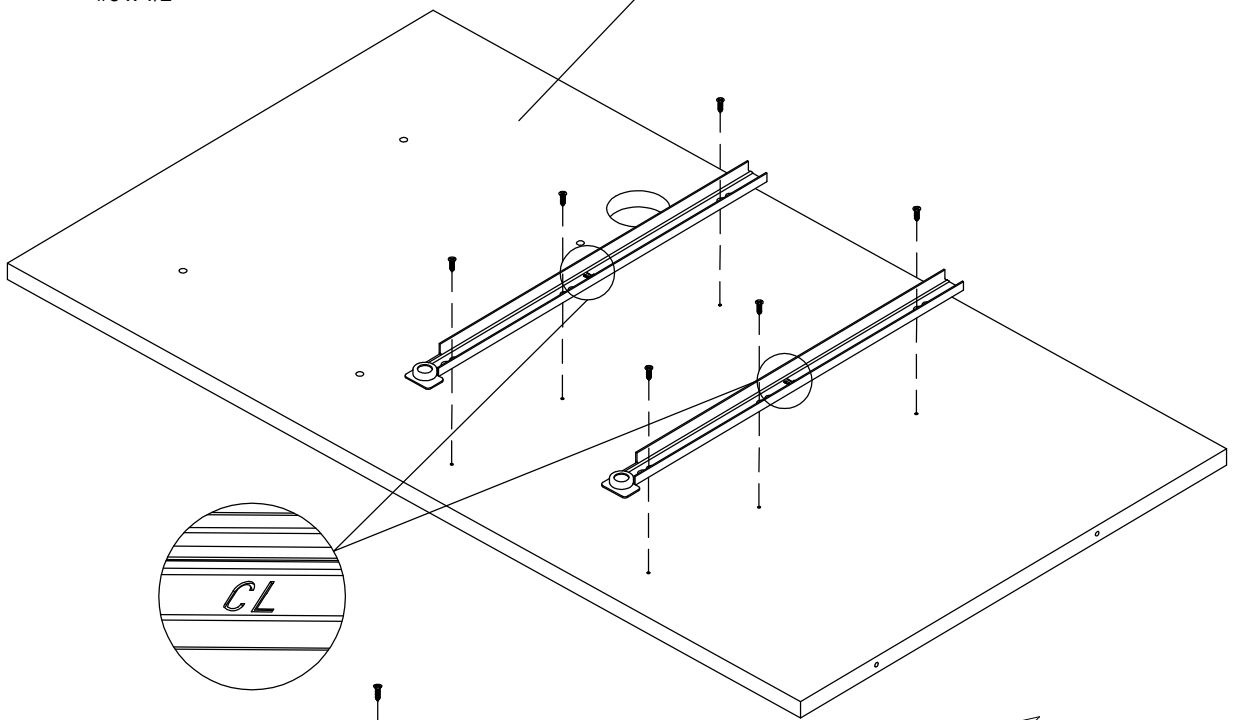

Z89899

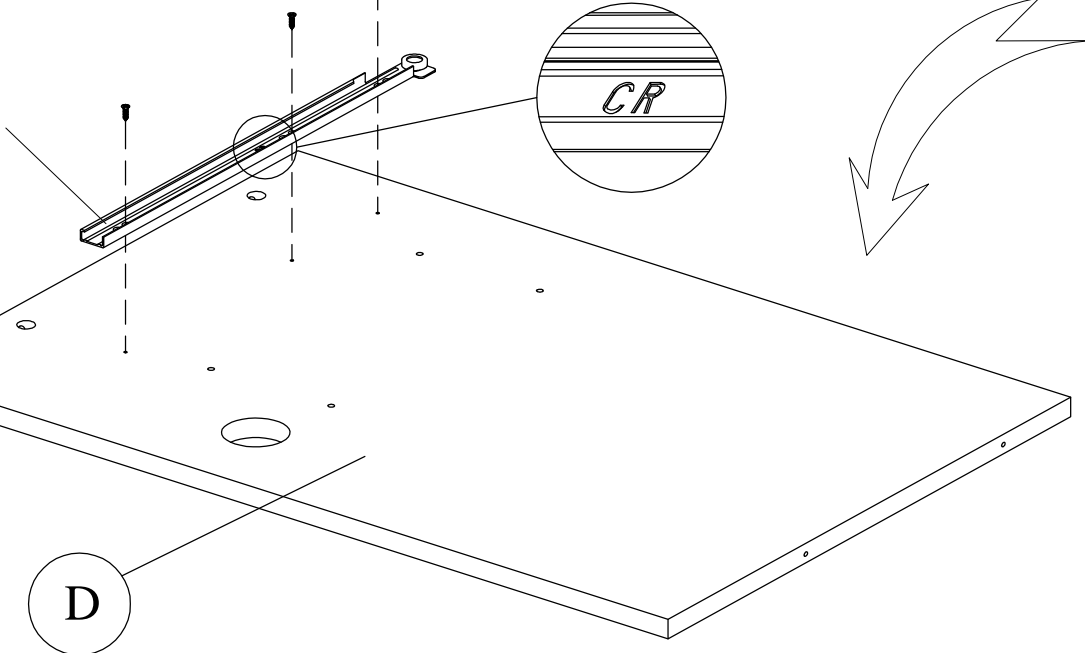

H156849

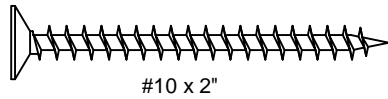

[ 2 ]

#10 x 2"

H159916



[ 2 ]

KD Cam

Finished edge  
Borde terminado  
Cote fini

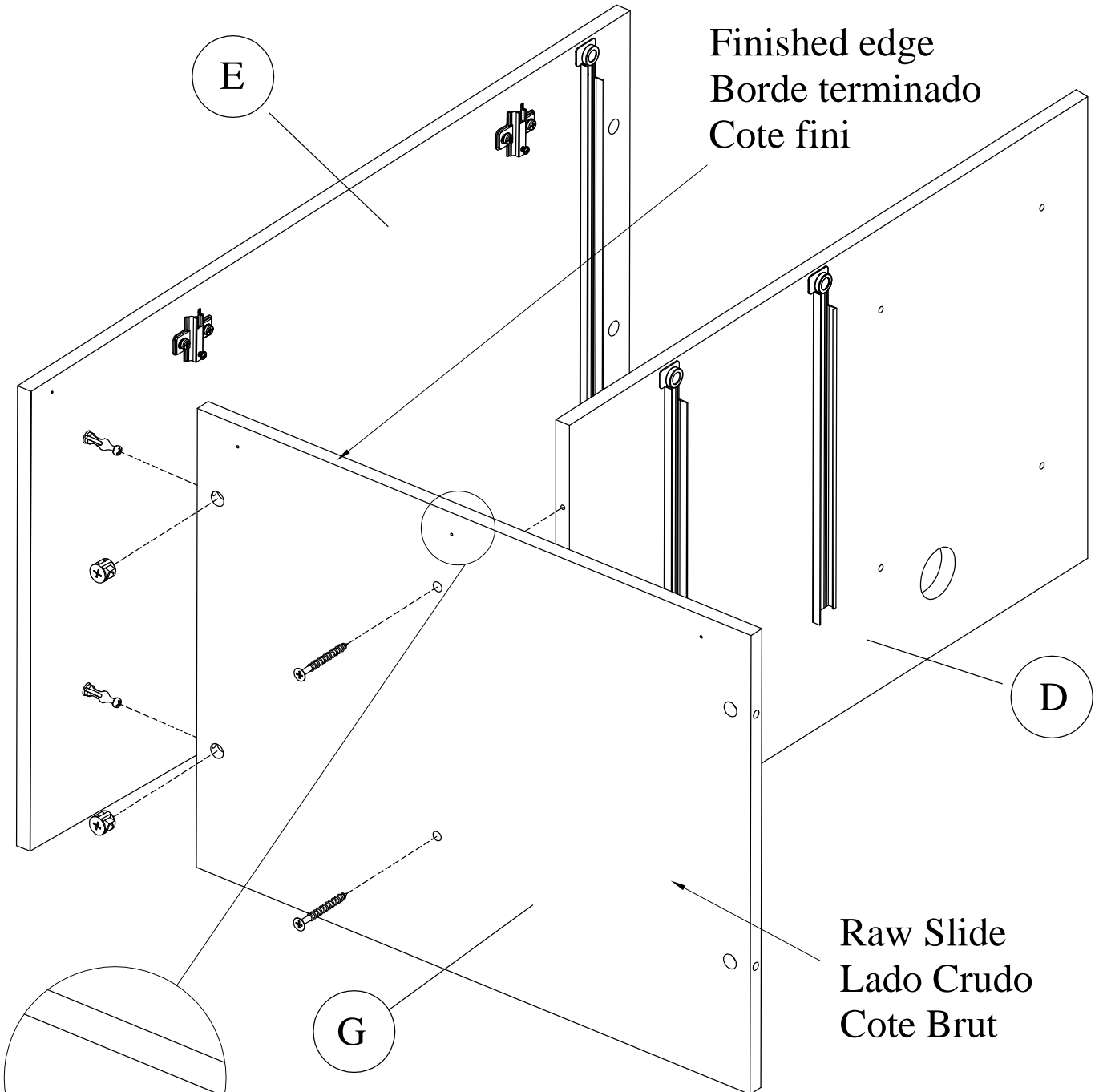

Raw Slide  
Lado Crudo  
Cote Brut

An assistant is required.  
Es necesario un ayudante.  
Un assistant est nécessaire.



H156849

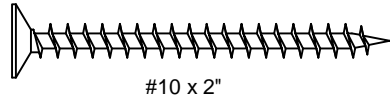

[ 2 ]

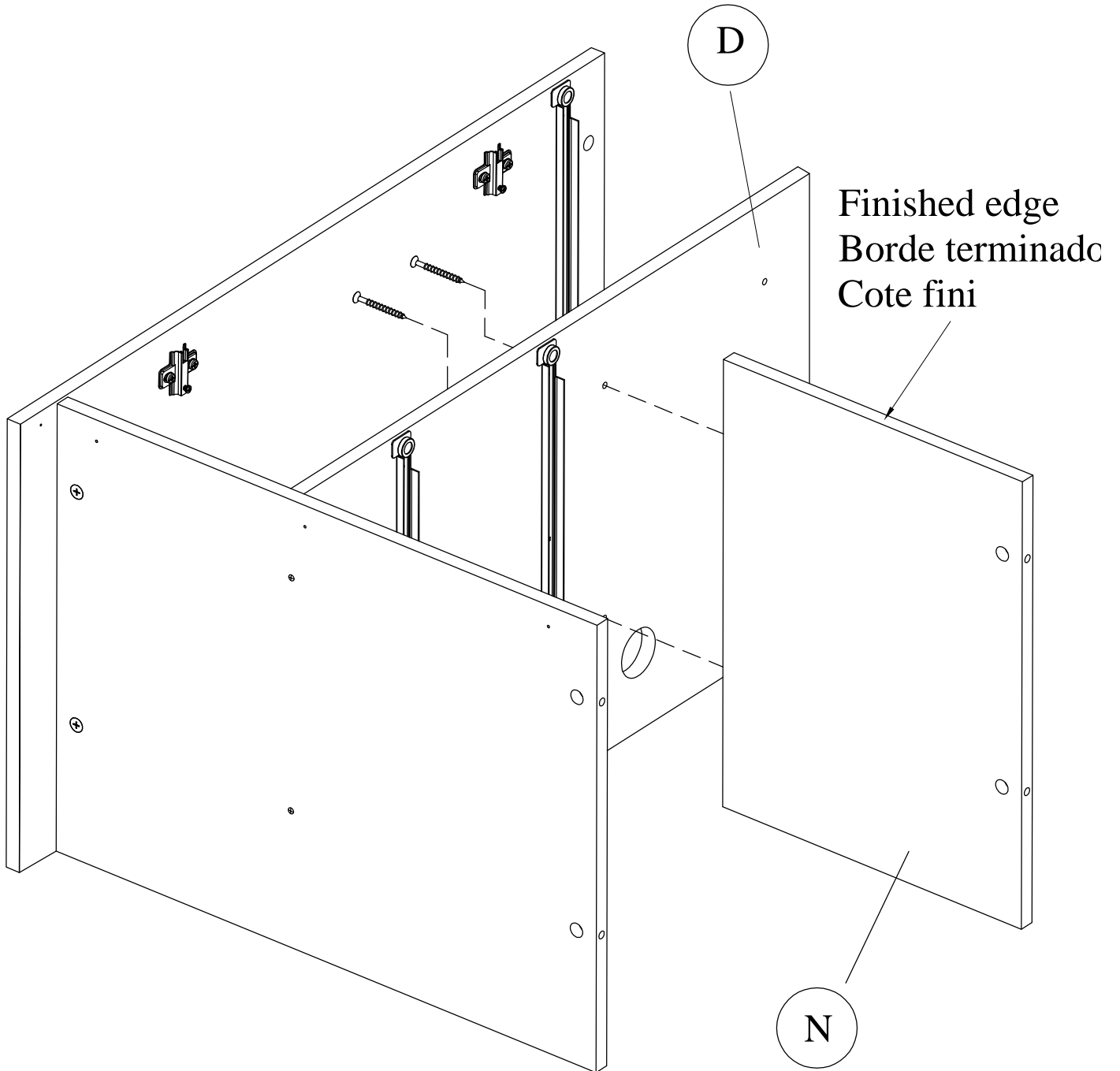

Finished edge  
Borde terminado  
Cote fini

D

N

Z89899

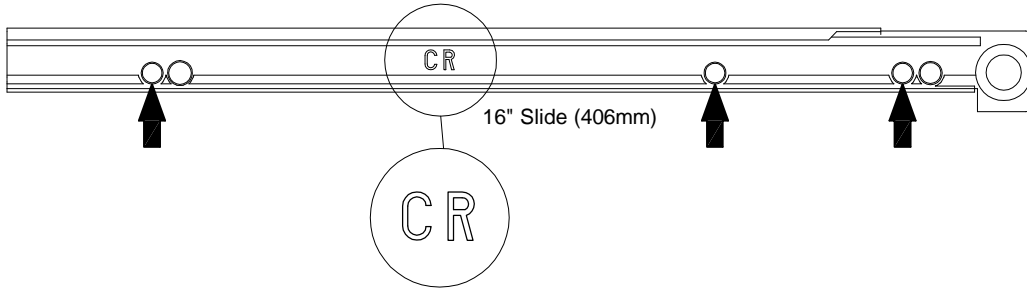

[ 2 ]

H159917

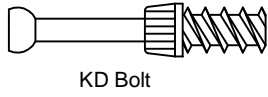

[ 4 ]

H124395

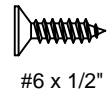

[ 6 ]

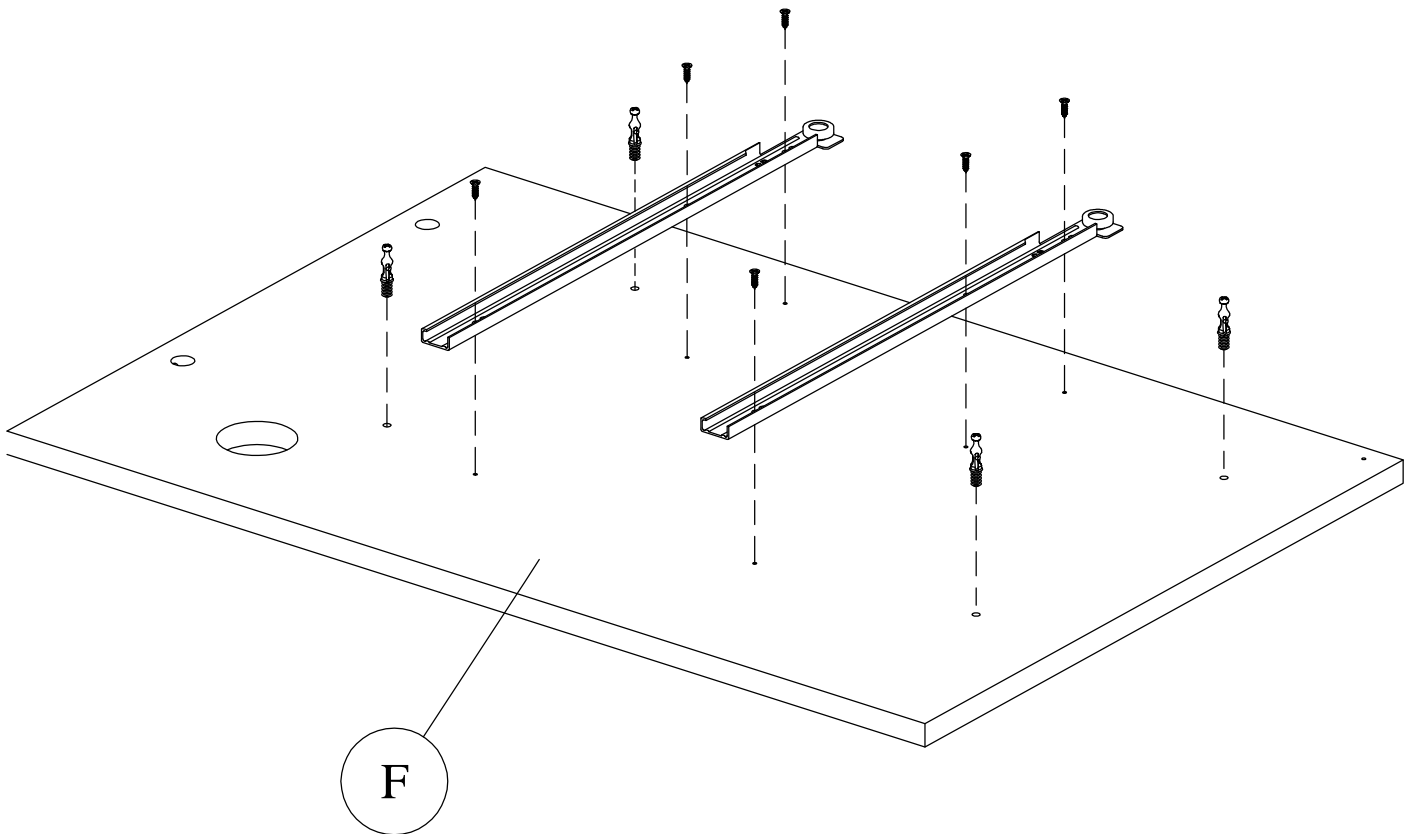

H159916



[ 4 ]

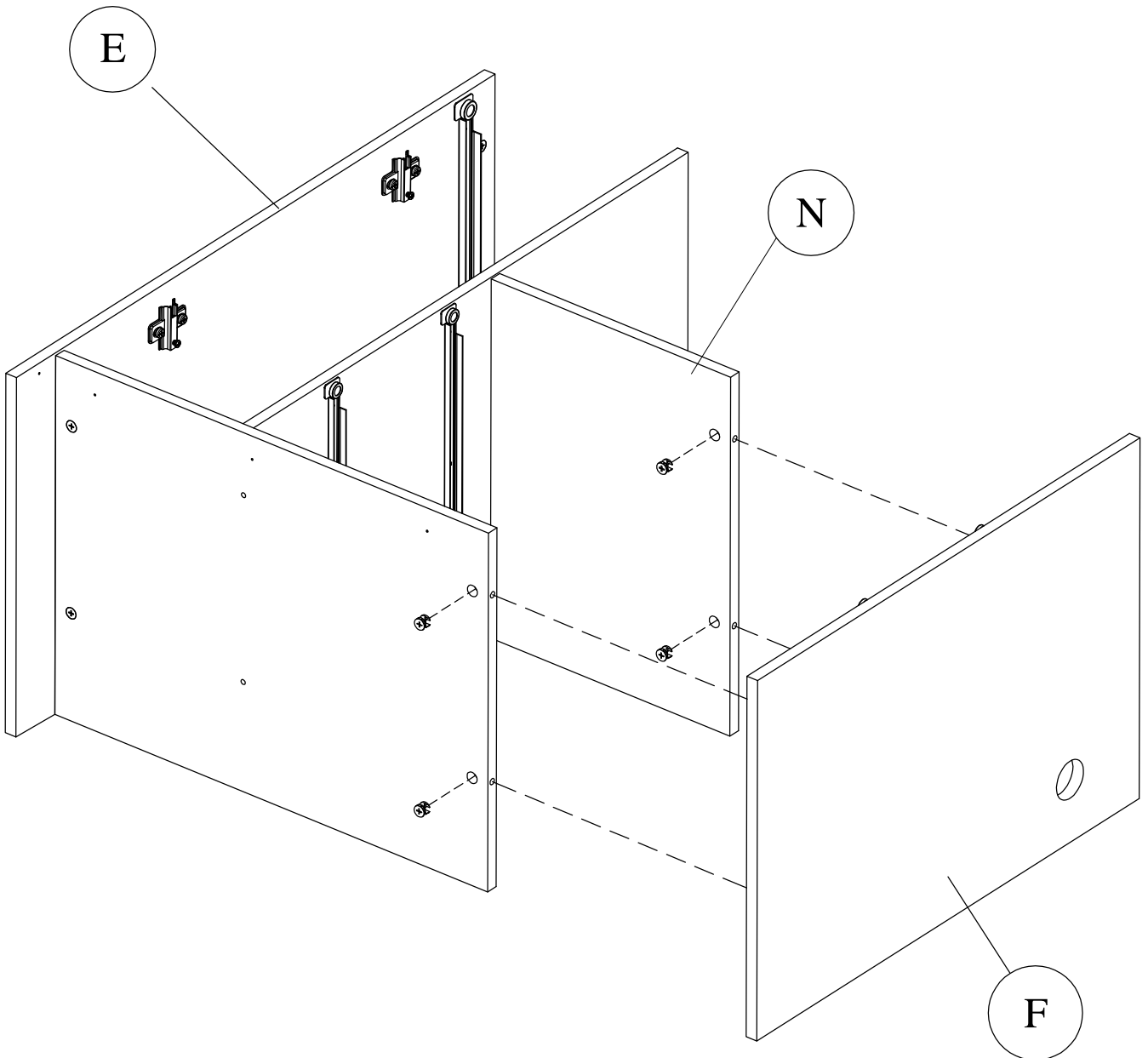

H20385



Tack Glide

[ 4 ]

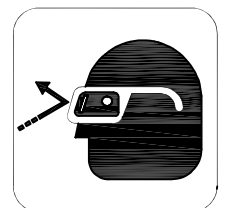
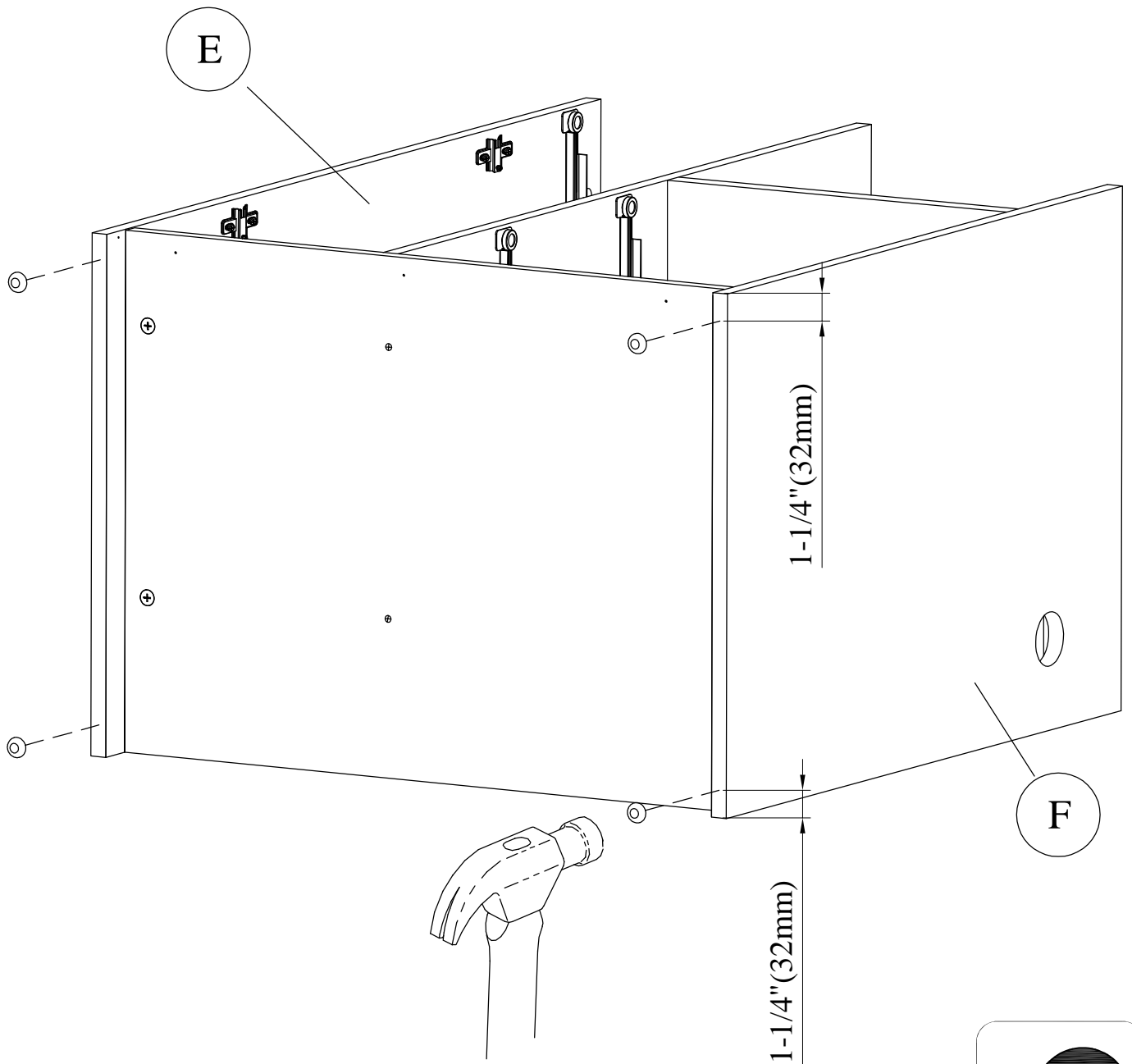

H137197

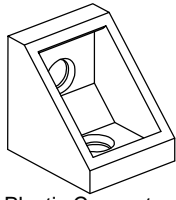

Plastic Connector

[ 5 ]

H27310

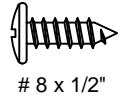

# 8 x 1/2"

[ 10 ]

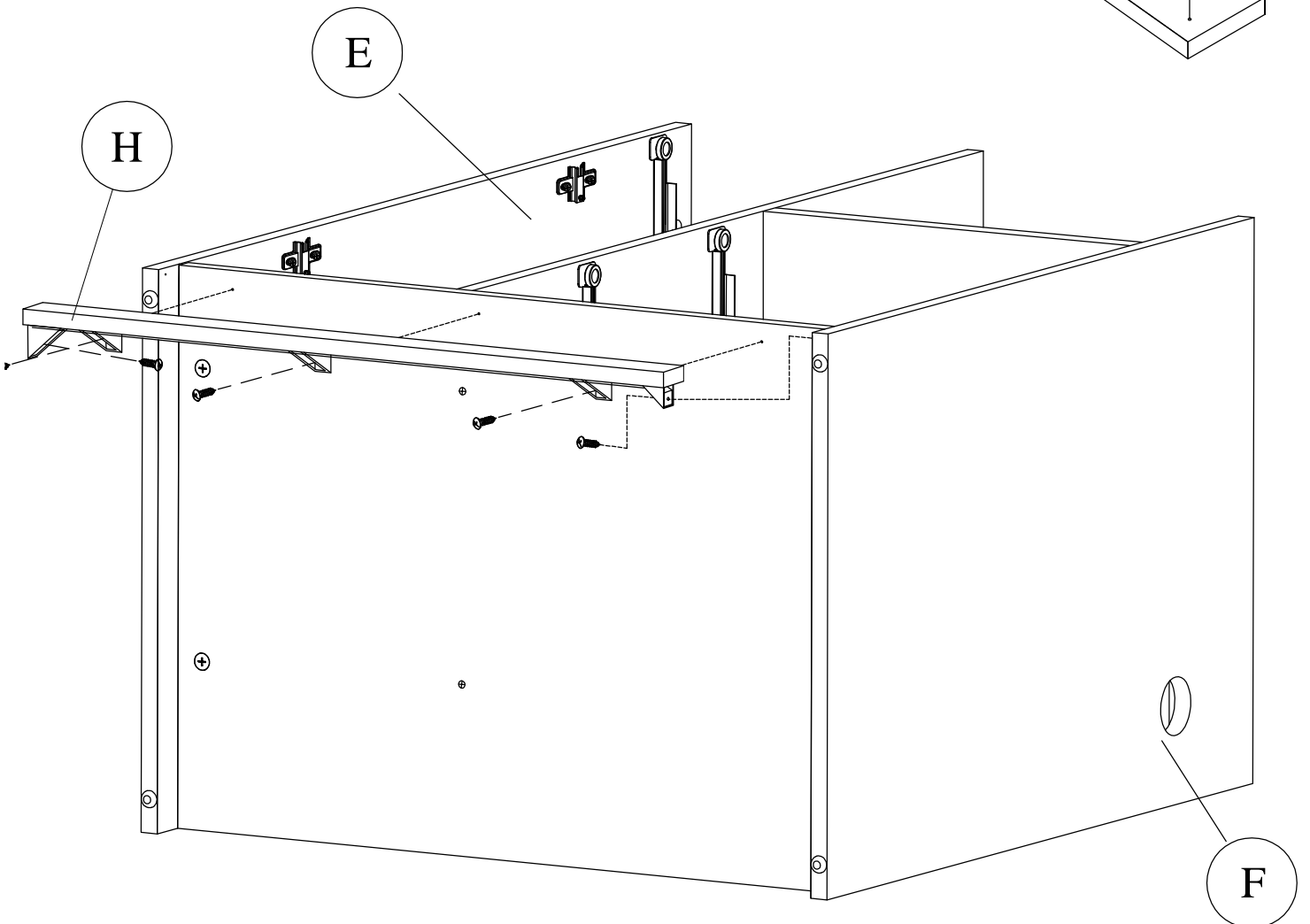
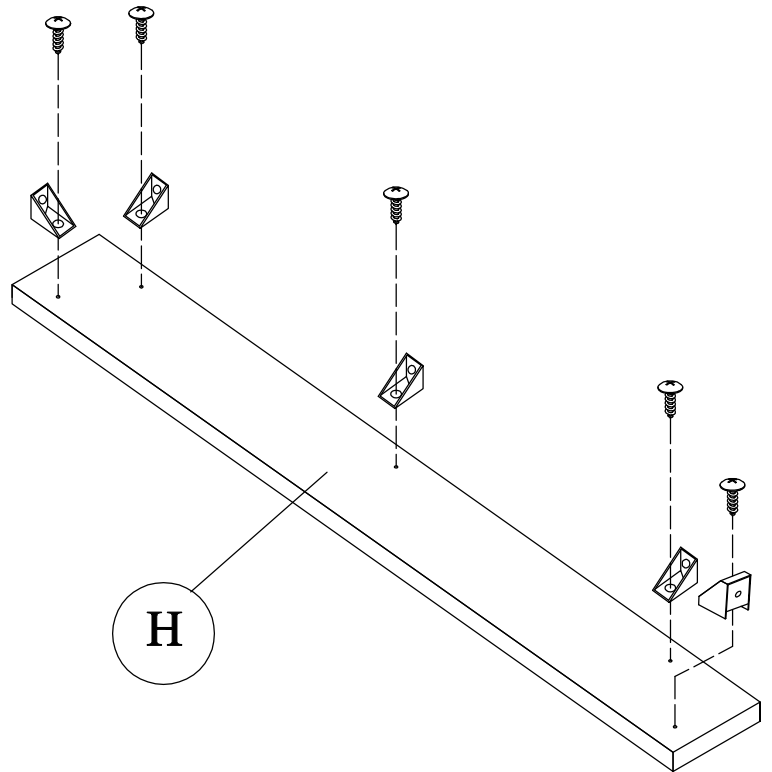

H159917

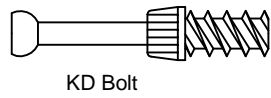

[ 4 ]

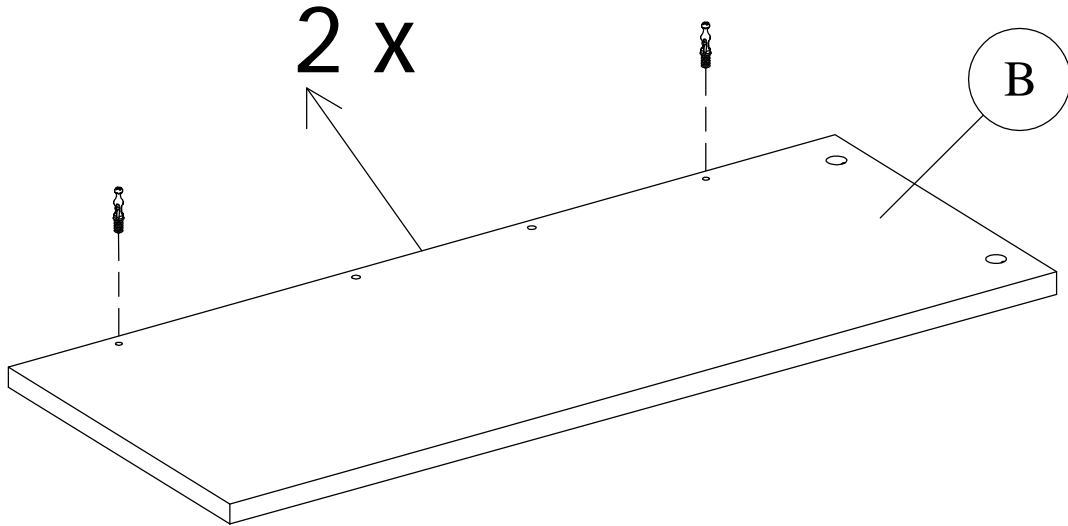

H156854



[ 4 ]

Wood Dowel Ø6 x 25mm

H27145

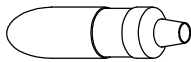

Glue

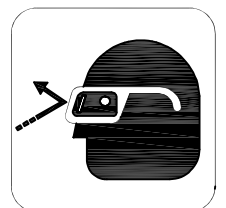
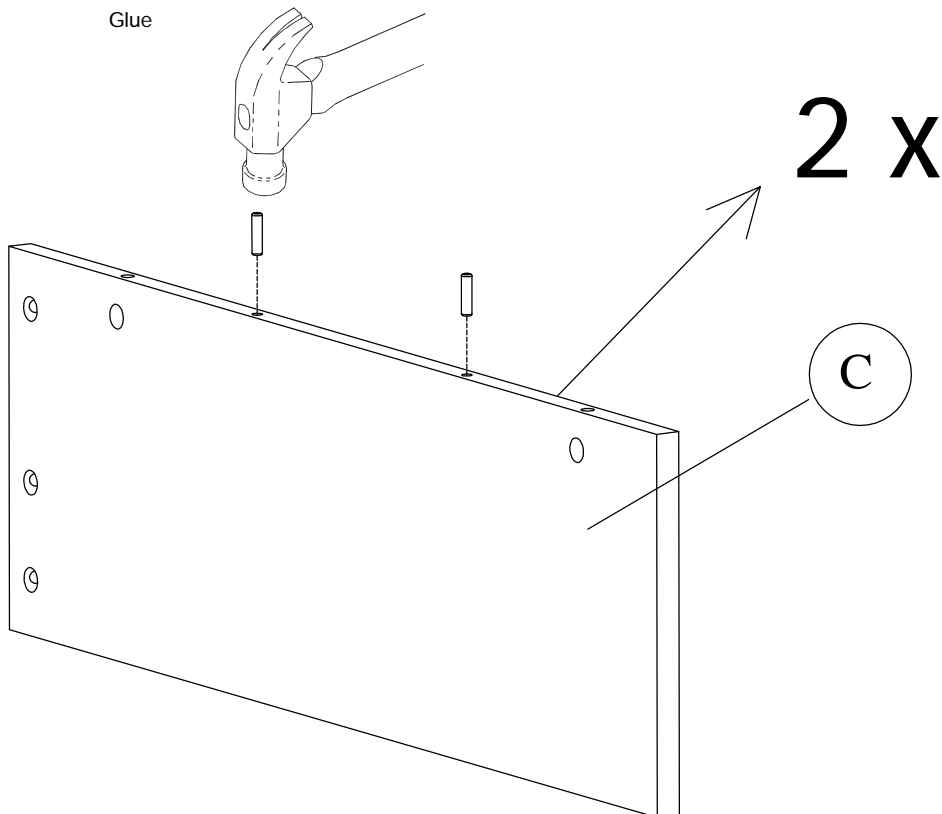

H159916



KD Cam

[ 4 ]

H27145



Glue

HM66315A	HM66615A	HM66915A	HM66115A
<b>H159895</b> Quantity <b>4</b>	<b>H95137</b> Quantity <b>4</b>	<b>H73621</b> Quantity <b>4</b>	<b>H170033</b> Quantity <b>4</b>
Cover Cap	Cover Cap	Cover Cap	Cover Cap

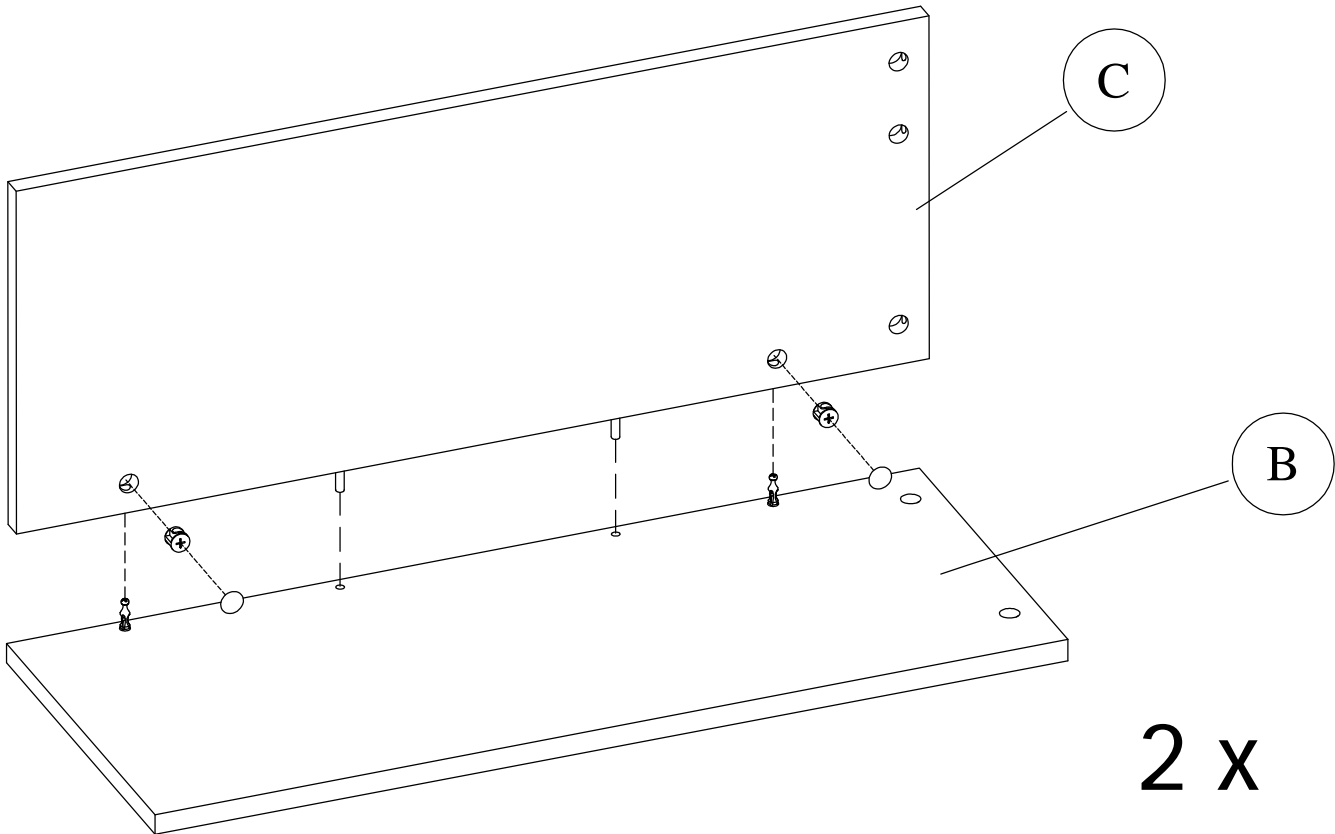

H159917

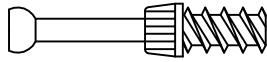

KD Bolt



[ 12 ]

H159916



KD Cam

[ 10 ]

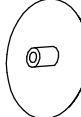
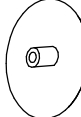
<p><b>HM66315A</b></p> <p><b>H159895</b> <b>Quantity 10</b></p>  <p>Cover Cap</p>	<p><b>HM66615A</b></p> <p><b>H95137</b> <b>Quantity 10</b></p>  <p>Cover Cap</p>	<p><b>HM66915A</b></p> <p><b>H73621</b> <b>Quantity 10</b></p>  <p>Cover Cap</p>	<p><b>HM66115A</b></p> <p><b>H170033</b> <b>Quantity 10</b></p>  <p>Cover Cap</p>
--	---	---	--

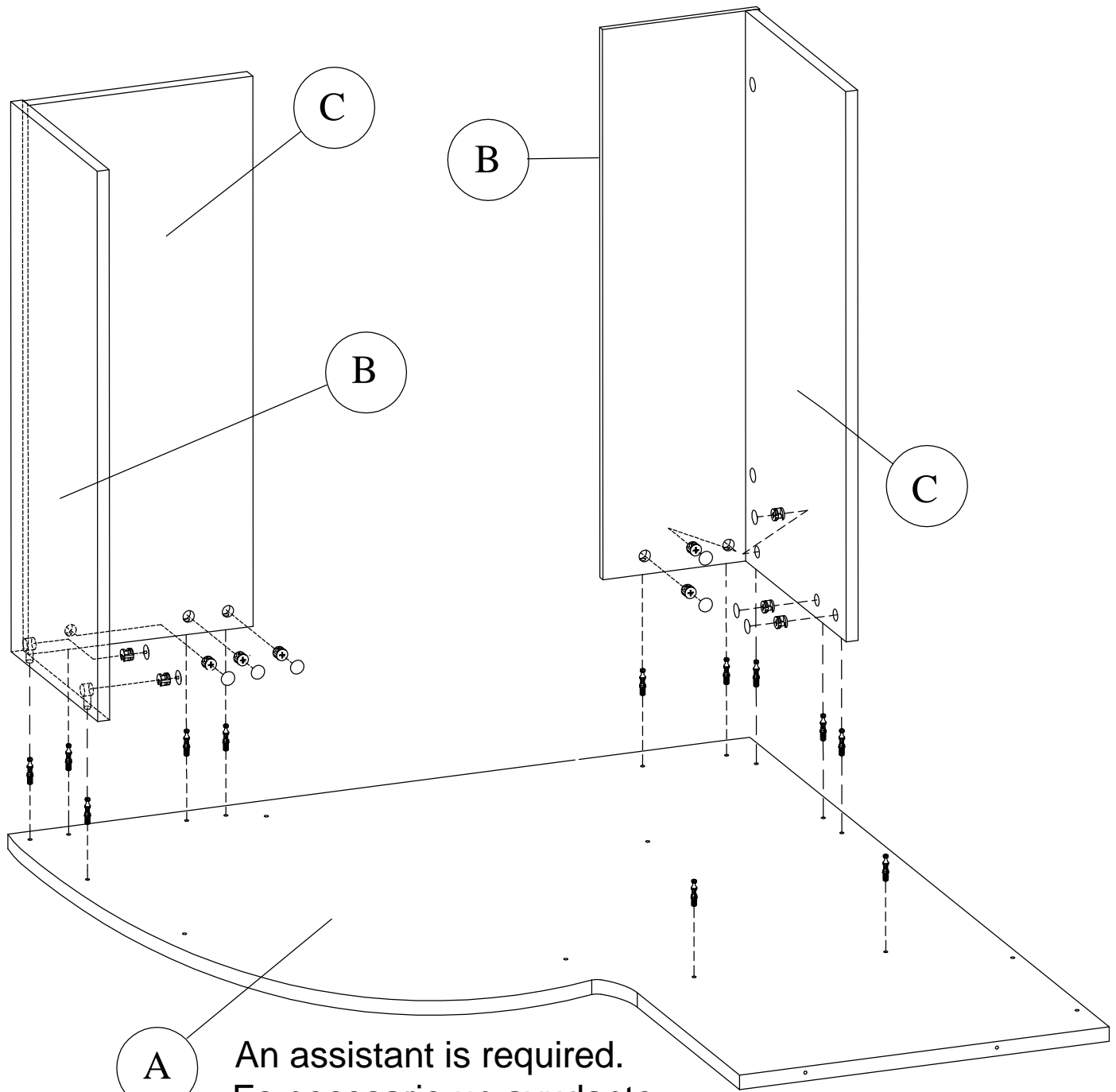

A

An assistant is required.  
 Es necesario un ayudante.  
 Un assistant est nécessaire.



H20385



Tack Glide

[ 6 ]

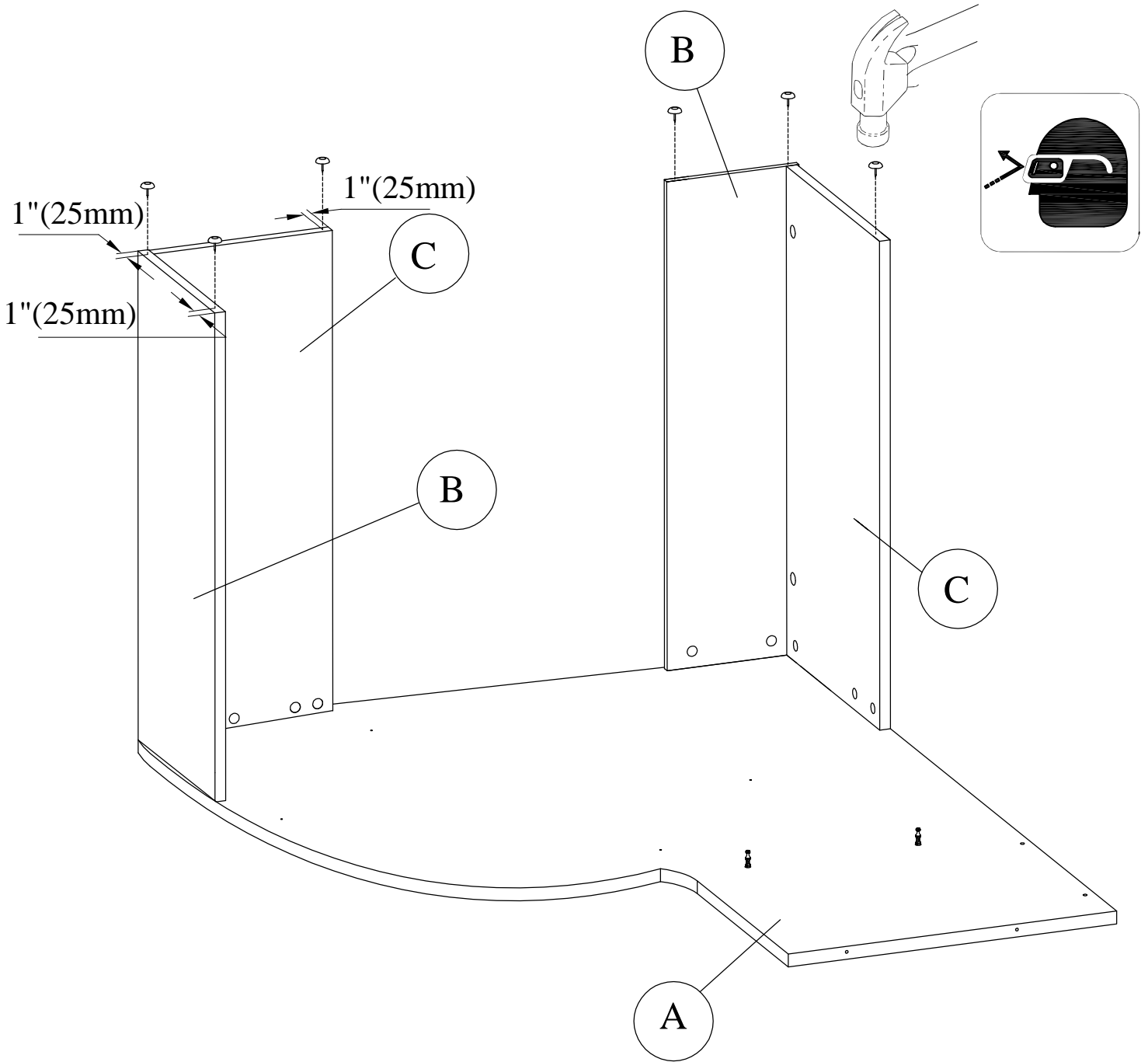

H156849

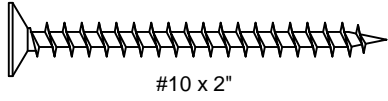

[ 2 ] H159916



[ 2 ]

HM66315A	HM66615A	HM66915A	HM66115A
H159895	H95137	H73621	H170033
Quantity <b>2</b>	Quantity <b>2</b>	Quantity <b>2</b>	Quantity <b>2</b>
Cover Cap	Cover Cap	Cover Cap	Cover Cap

With an assistant carefully stand unit upright.

Con un asistente cuidadosamente levante la unidad a una posición vertical.

Avec l'aide d'un assistant placez soigneusement l'unité debout.

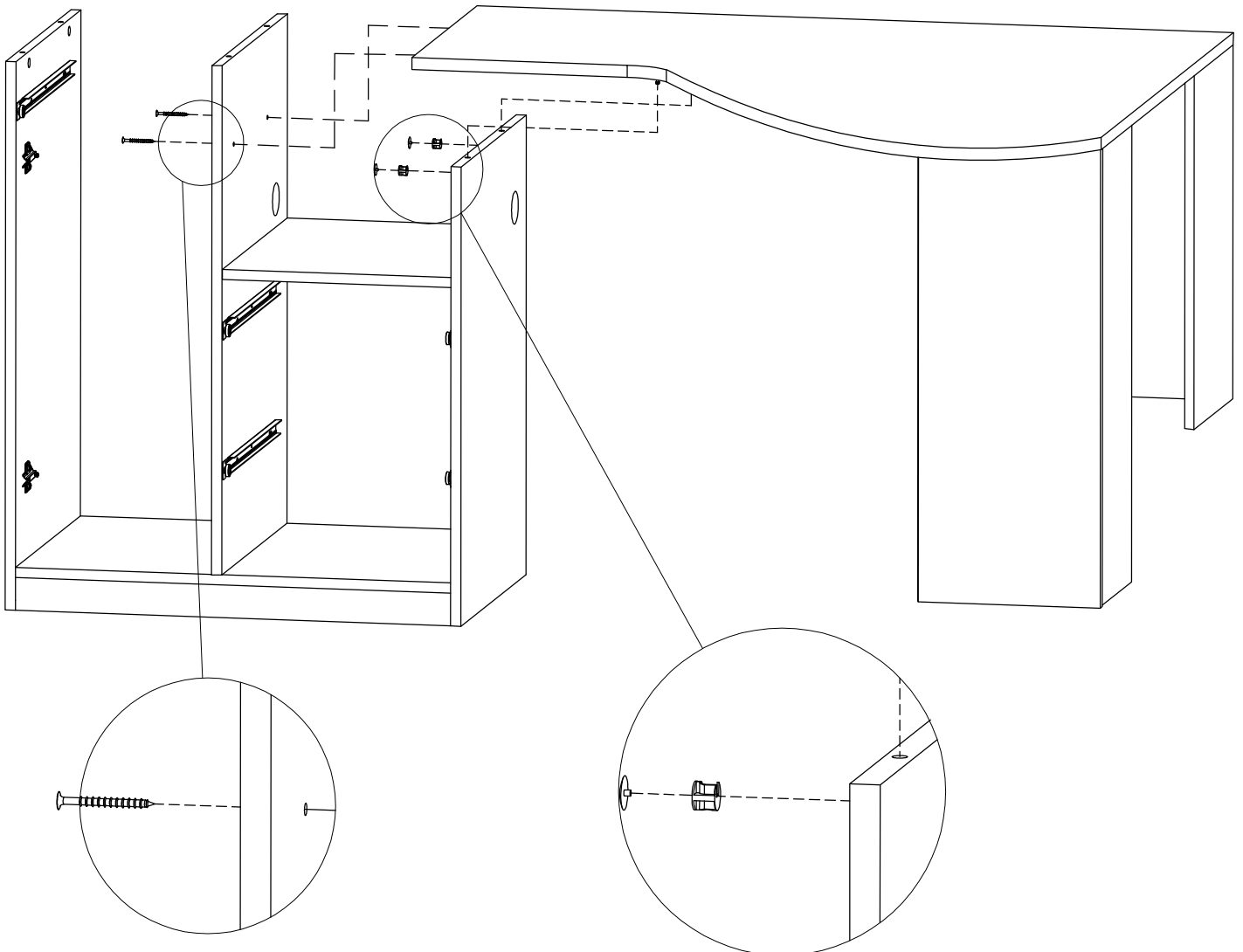

H156849

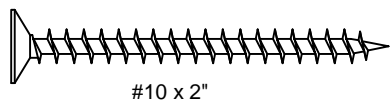

[ 2 ]

#10 x 2"

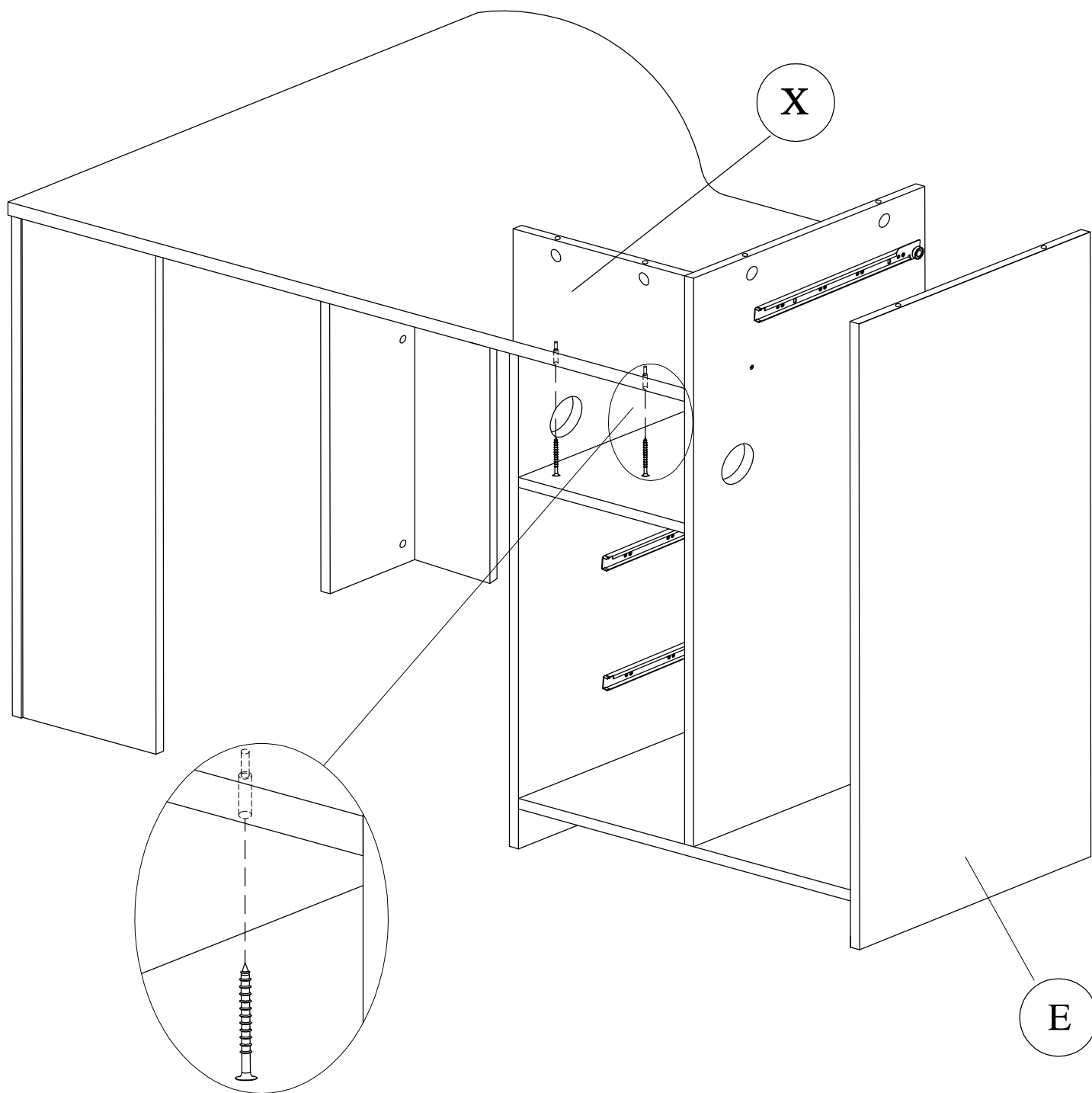

H159917

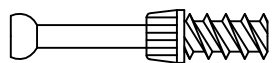

[ 6 ]

KD Bolt

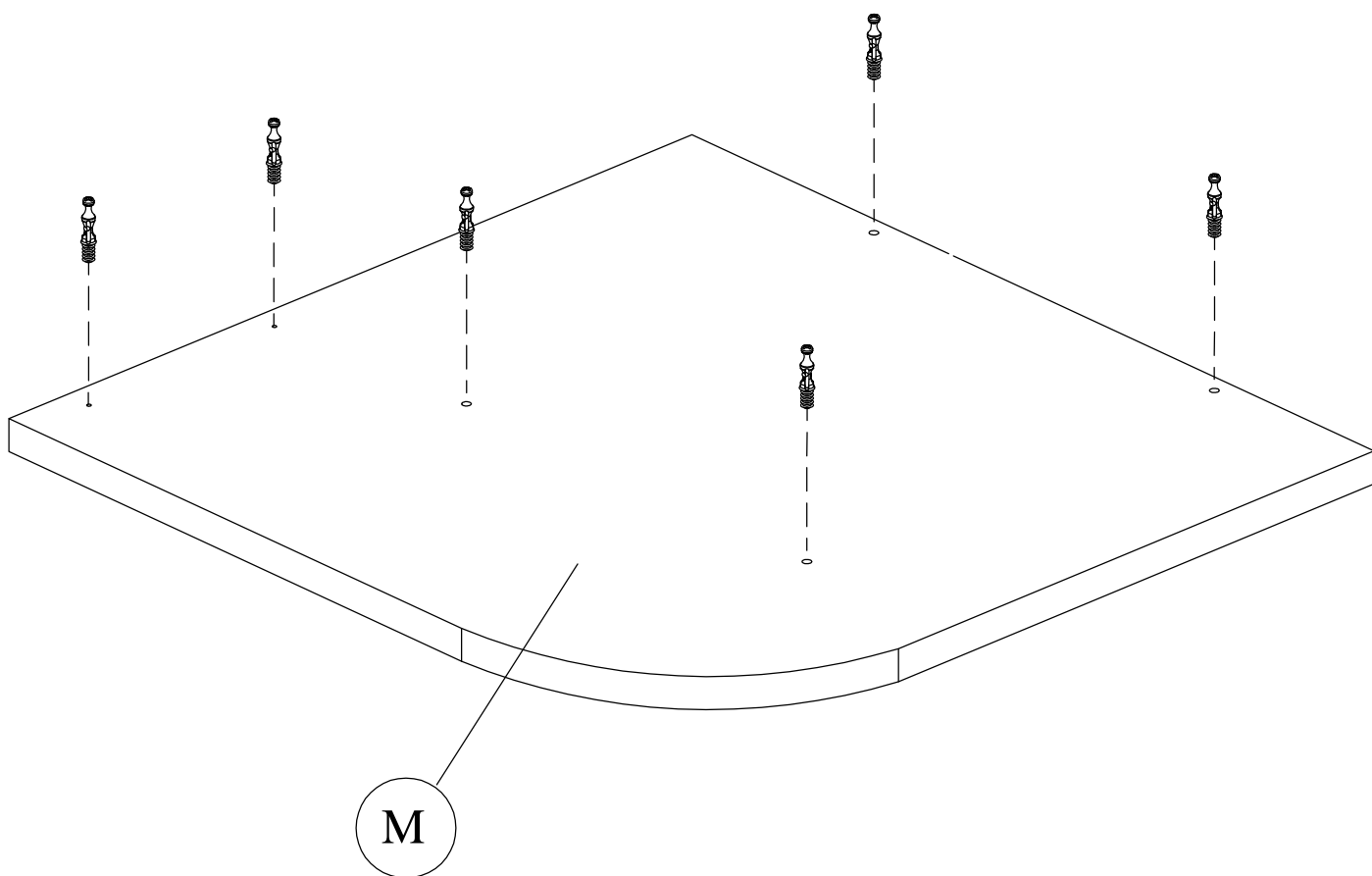

<b>HM66315A</b> H159895 Quantity 2 Cover Cap	<b>HM66615A</b> H95137 Quantity 2 Cover Cap	<b>HM66915A</b> H73621 Quantity 2 Cover Cap	<b>HM66115A</b> H170033 Quantity 2 Cover Cap
---	--	--	---

H159916



KD Cam

[ 6 ]

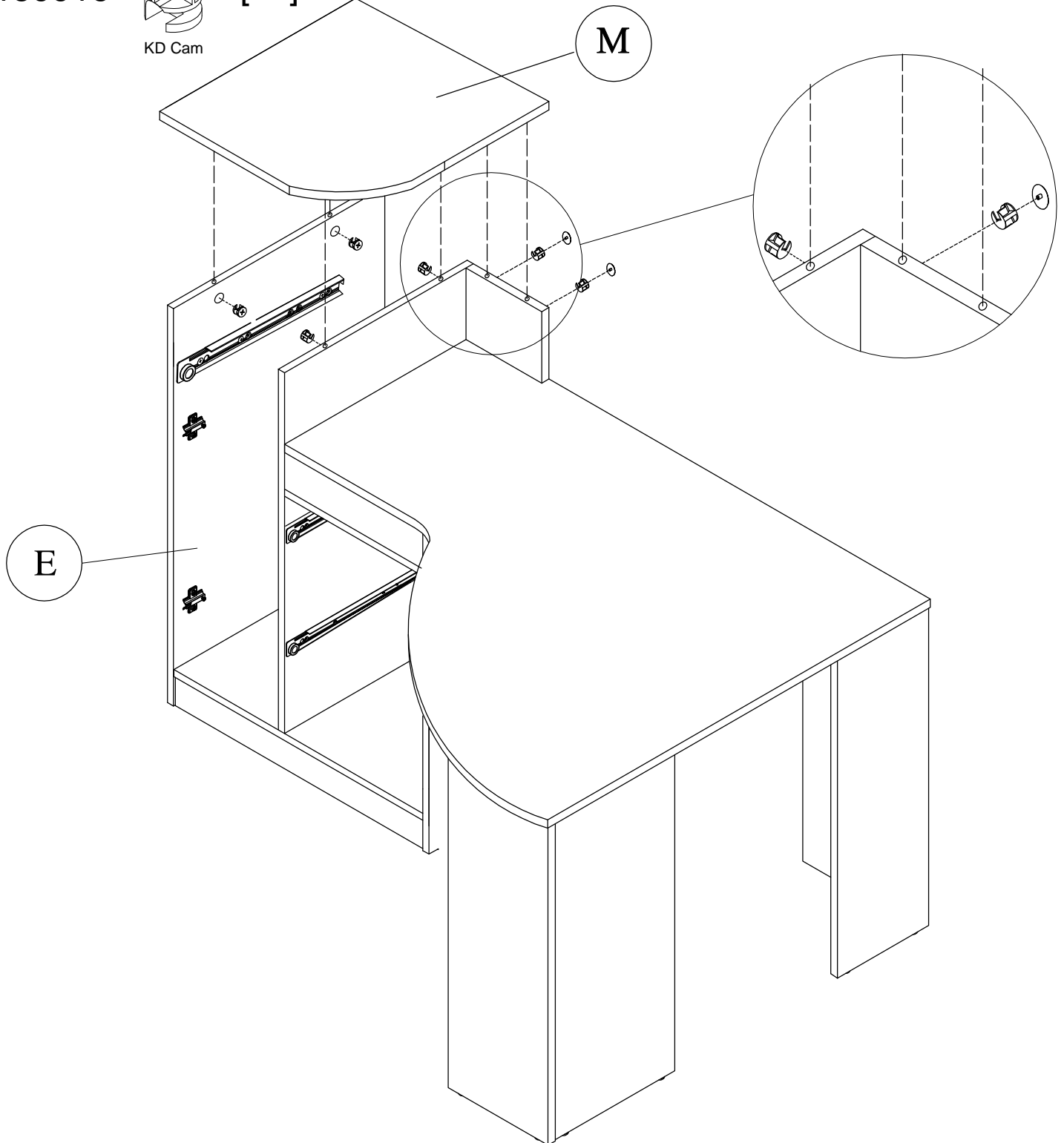

H34174



# 3 x 3/4"

[ 35 ]

An assistant may be required.

Un asistente puede ser necesario.

L'aide d'une autre personne peut s'avérer nécessaire.

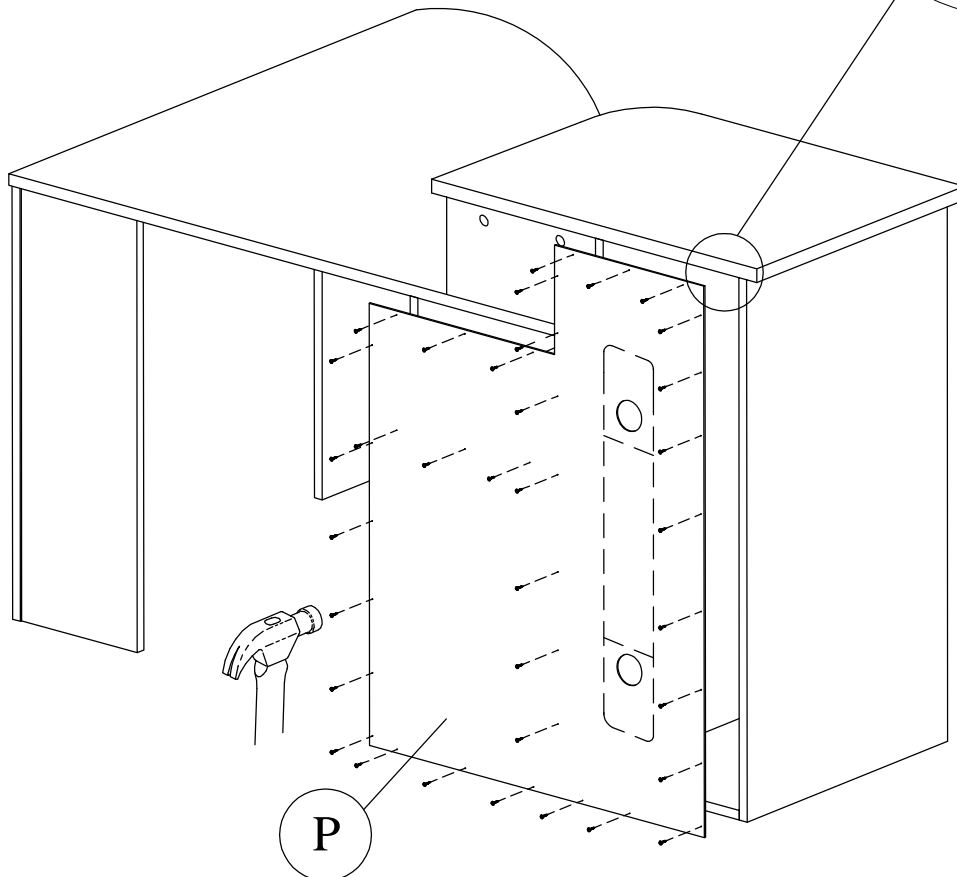
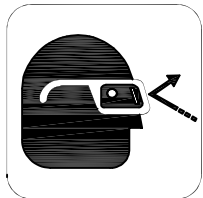
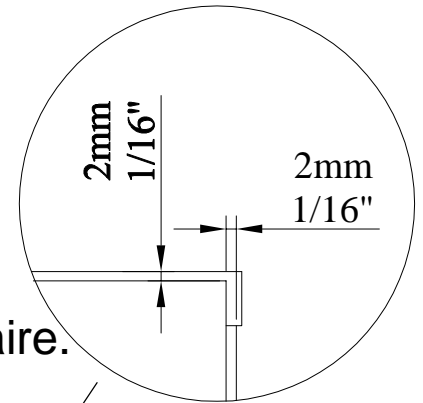

## WARNING

Do not load unit without properly attaching back panel. Doing so could cause instability, product collapse, and/or serious injury.

No cargue esta unidad sin el panel de atrás. Hacerlo puede causar inestabilidad, que el producto se derrumbe, y/o heridas (golpes) serias.

Ne pas charger le produit sans attacher correctement le panneau arrière. Faire ainsi peut causer l'instabilité ou l'effondrement du produit et peut vous causer des endommagements sérieux.

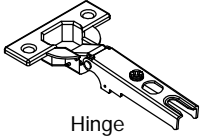
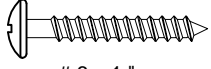
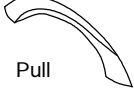
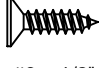
- |         |  |       |         |  |       |
|---------|--|-------|---------|--|-------|
| H136463 | <br>Hinge | [ 2 ] | H152964 | <br># 6 x 1 " | [ 2 ] |
| H154711 | <br>Pull  | [ 1 ] | H124395 | <br>#6 x 1/2" | [ 4 ] |

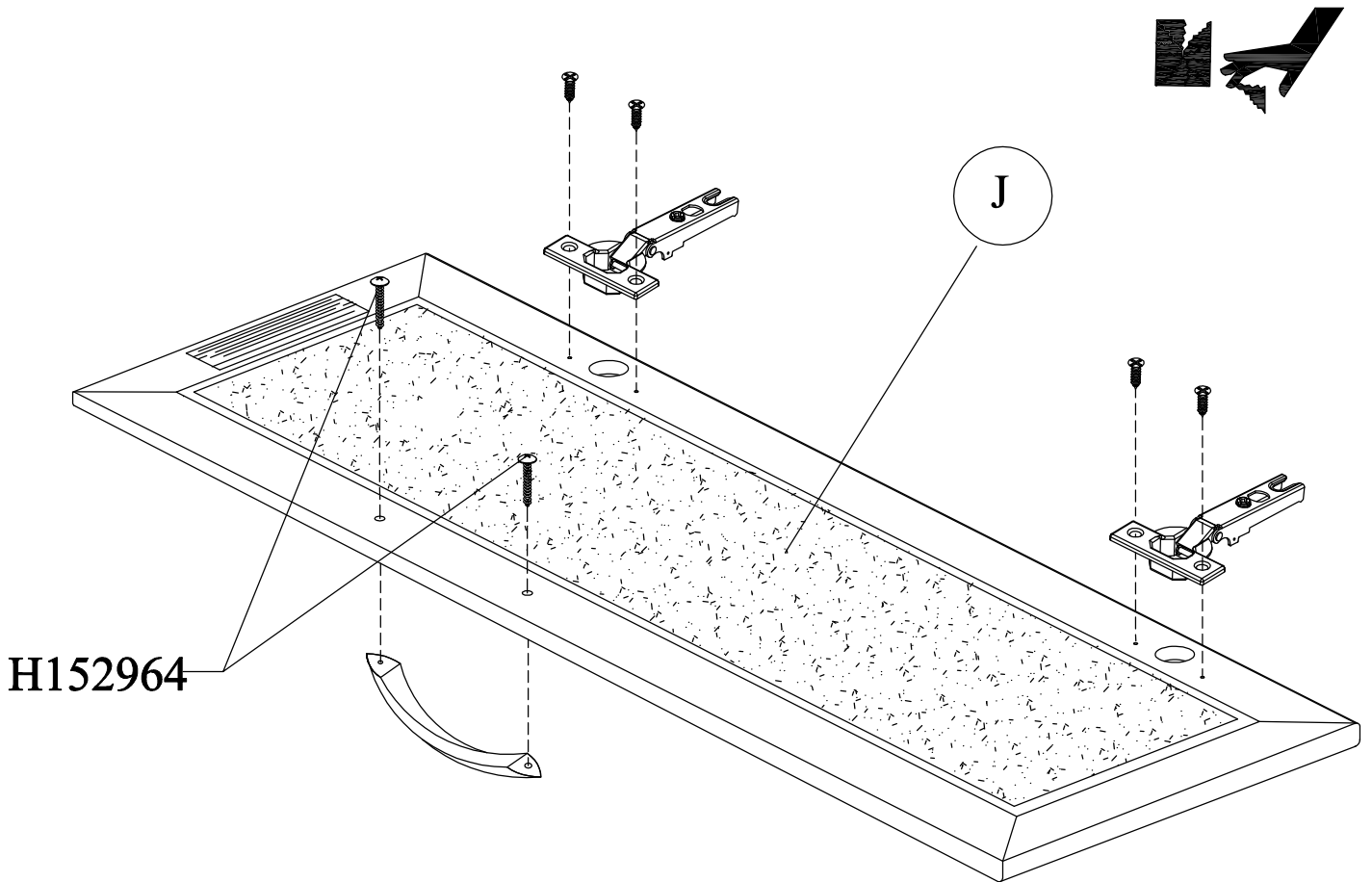

**CAUTION**



RISK OF BREAKING GLASS.  
HANDLE GLASS CAREFULLY  
DURING ASSEMBLY. USE EYE  
AND HAND PROTECTION.  
IMPROPER HANDLING CAN  
RESULT IN CUTS OR  
LACERATIONS.

RIESGO DE ROMPER EL VIDRIO.  
MANEJE EL VIDRIO CON  
CUIDADO AL ENSAMBLAR ESTA  
UNIDAD. USE PROTECCIÓN  
PARA SUS OJOS Y SUS MANOS.  
EL MANEJO INAPROPIADO DEL  
VIDRIO PUEDE CAUSARLE  
CORTADURAS O  
LACERACIONES.

RISQUE DE BRIS DE VERRE. FAITES  
ATTENTION LORS DE LA  
MANIPULATION DU VERRE PENDANT  
L'ASSEMBLAGE. UTILISEZ DES  
PROTECTIONS POUR LES YEUX ET  
LES MAINS. UNE MAUVAISE  
MANIPULATION PEUT PROVOQUER  
DES COUPURES OU DES  
LACÉRATIONS.

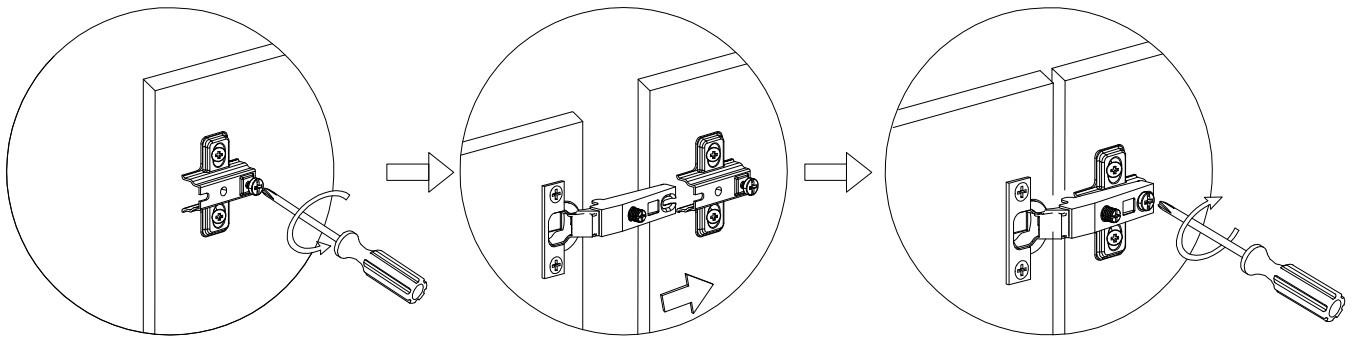

1

2

3

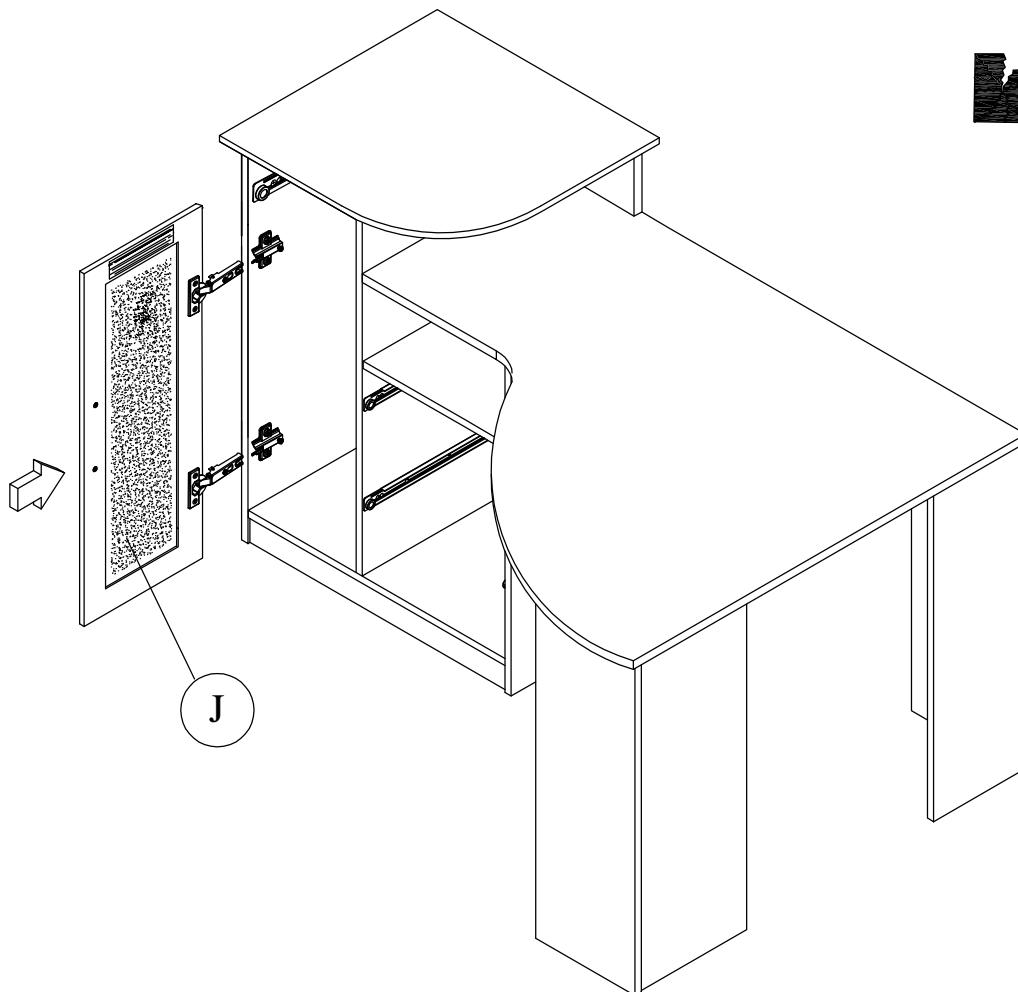



**CAUTION**

RISK OF BREAKING GLASS.  
HANDLE GLASS CAREFULLY  
DURING ASSEMBLY. USE EYE  
AND HAND PROTECTION.  
IMPROPER HANDLING CAN  
RESULT IN CUTS OR  
LACERATIONS.

RIESGO DE ROMPER EL VIDRIO.  
MANEJE EL VIDRIO CON  
CUIDADO AL ENSAMBLAR ESTA  
UNIDAD. USE PROTECCIÓN  
PARA SUS OJOS Y SUS MANOS.  
EL MANEJO INAPROPIADO DEL  
VIDRIO PUEDE CAUSARLE  
CORTADURAS O  
LACERACIONES.

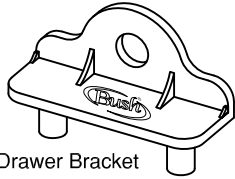
RISQUE DE BRIS DE VERRE. FAITES  
ATTENTION LORS DE LA  
MANIPULATION DU VERRE PENDANT  
L'ASSEMBLAGE. UTILISEZ DES  
PROTECTIONS POUR LES YEUX ET  
LES MAINS. UNE MAUVAISE  
MANIPULATION PEUT PROVOQUER  
DES COUPURES OU DES  
LACÉRATIONS.



- |         |   |       |         |  |       |
|---------|---|-------|---------|--|-------|
| H100444 |  <p>Drawer Bracket</p> | [ 2 ] | H35251  |  <p># 10 x 1/2"</p> | [ 2 ] |
| H160125 |  <p>#10 x 1-1/2"</p>   | [ 4 ] | H101725 |  <p>#6 x 1/2"</p>   | [ 4 ] |

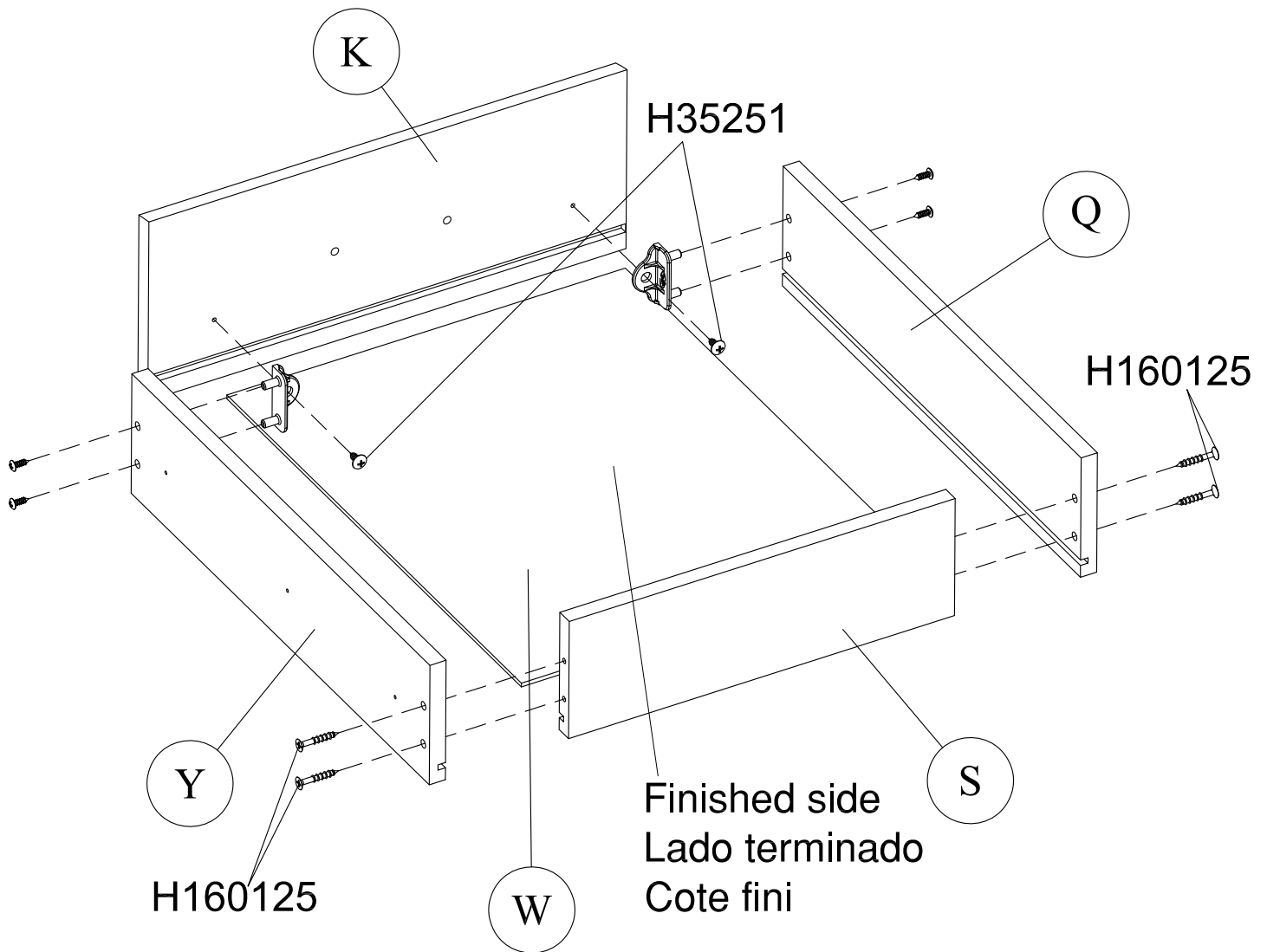

For drawer front adjustment please proceed to step 26.  
 Para ajustes de la parte delantera de las gavetas favor proceda al paso #26.  
 Pour l'ajustement de la façade de tiroir veuillez procéder à l'etape 26.

Z89901 16" Slide (406mm) [ 1 ]

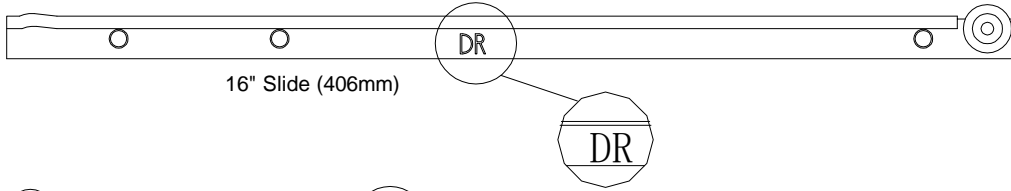

Z89900 16" Slide (406mm) [ 1 ]

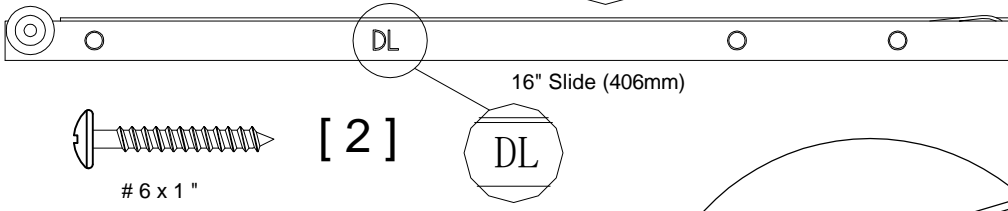

H152964 # 6 x 1 " [ 2 ]

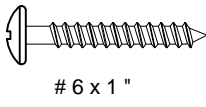

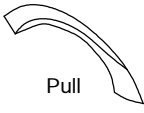

H154711 Pull [ 1 ]

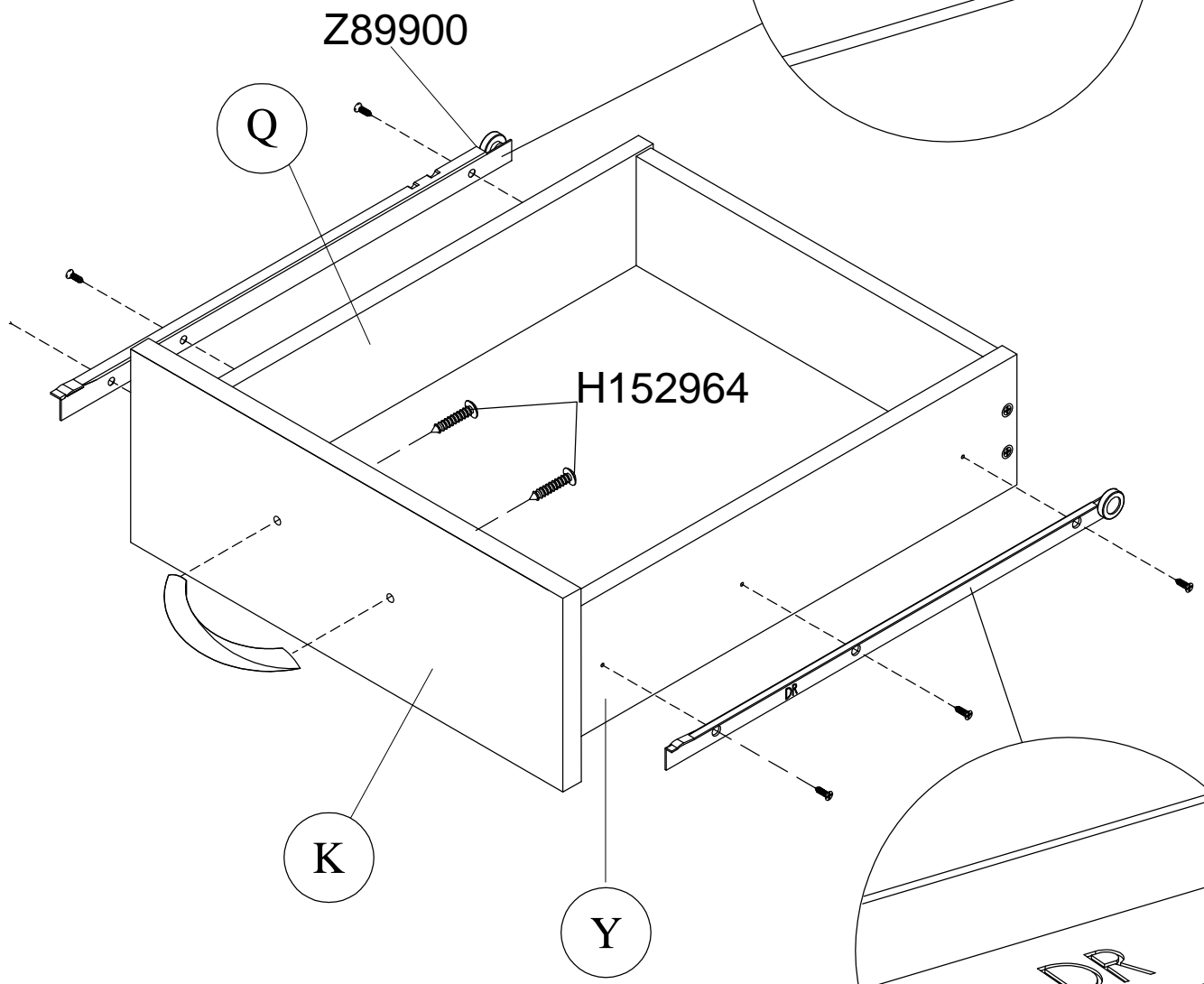
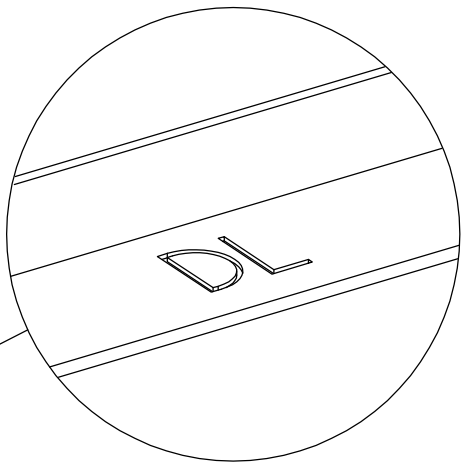
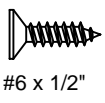

H124395 #6 x 1/2" [ 6 ]

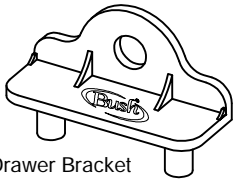
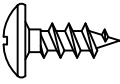

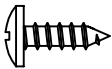
H100444	 <p>Drawer Bracket</p>	[ 2 ]	H35251	 <p># 10 x 1/2"</p>	[ 2 ]
H160125	 <p>#10 x 1-1/2"</p>	[ 4 ]	H101725	 <p>#6 x 1/2"</p>	[ 4 ]

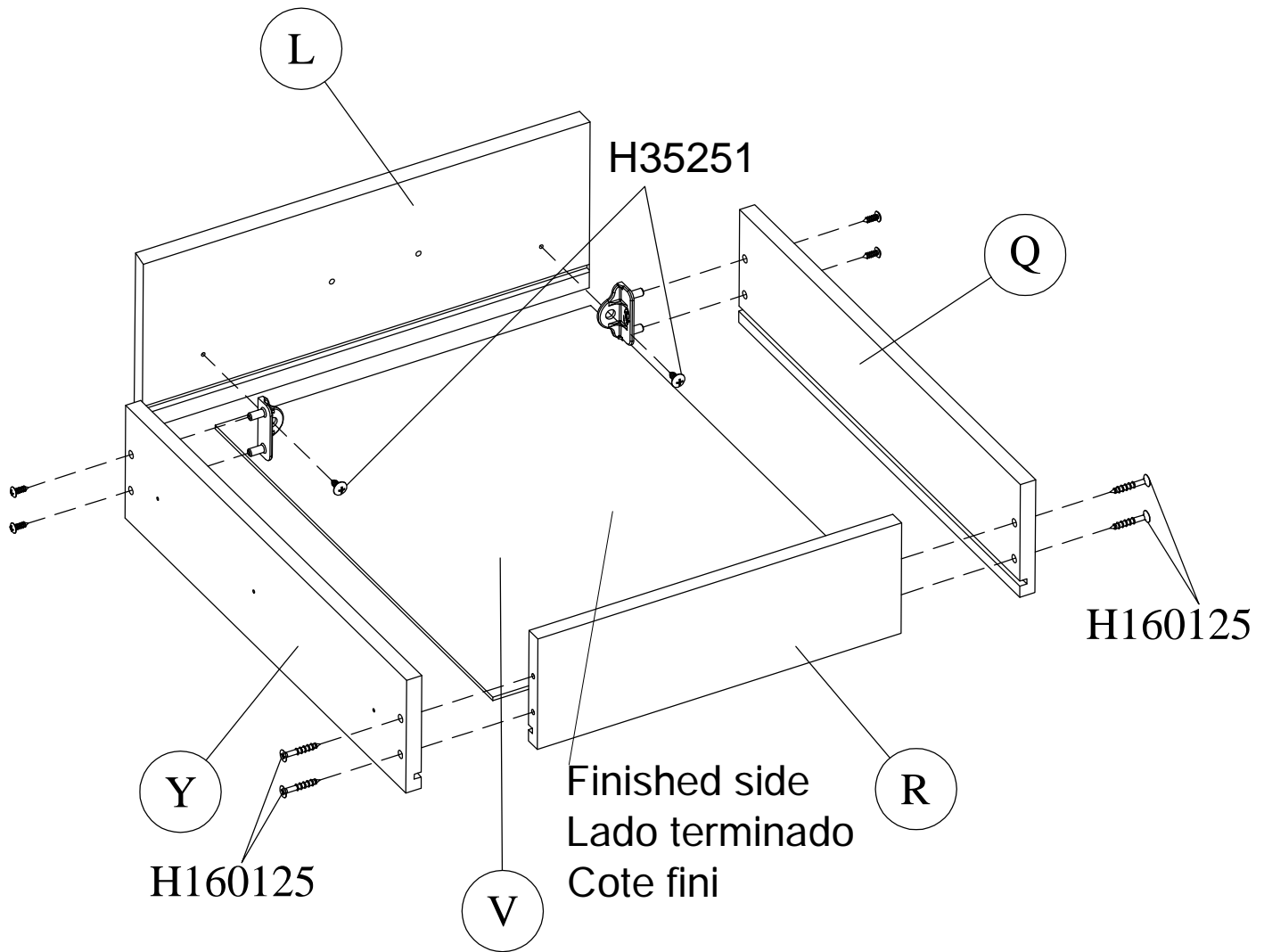

For drawer front adjustment please proceed to step 26.  
 Para ajustes de la parte delantera de las gavetas favor proceda al paso #26.  
 Pour l'ajustement de la façade de tiroir veuillez procéder à l'etape 26.

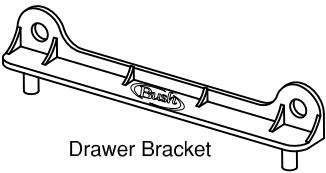
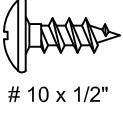
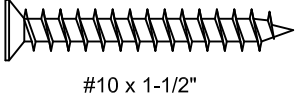
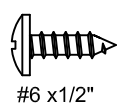
H100446	 <p>Drawer Bracket</p>	[ 2 ]	H35251	 <p># 10 x 1/2"</p>	[ 4 ]
H160125	 <p>#10 x 1-1/2"</p>	[ 4 ]	H101725	 <p>#6 x 1/2"</p>	[ 4 ]

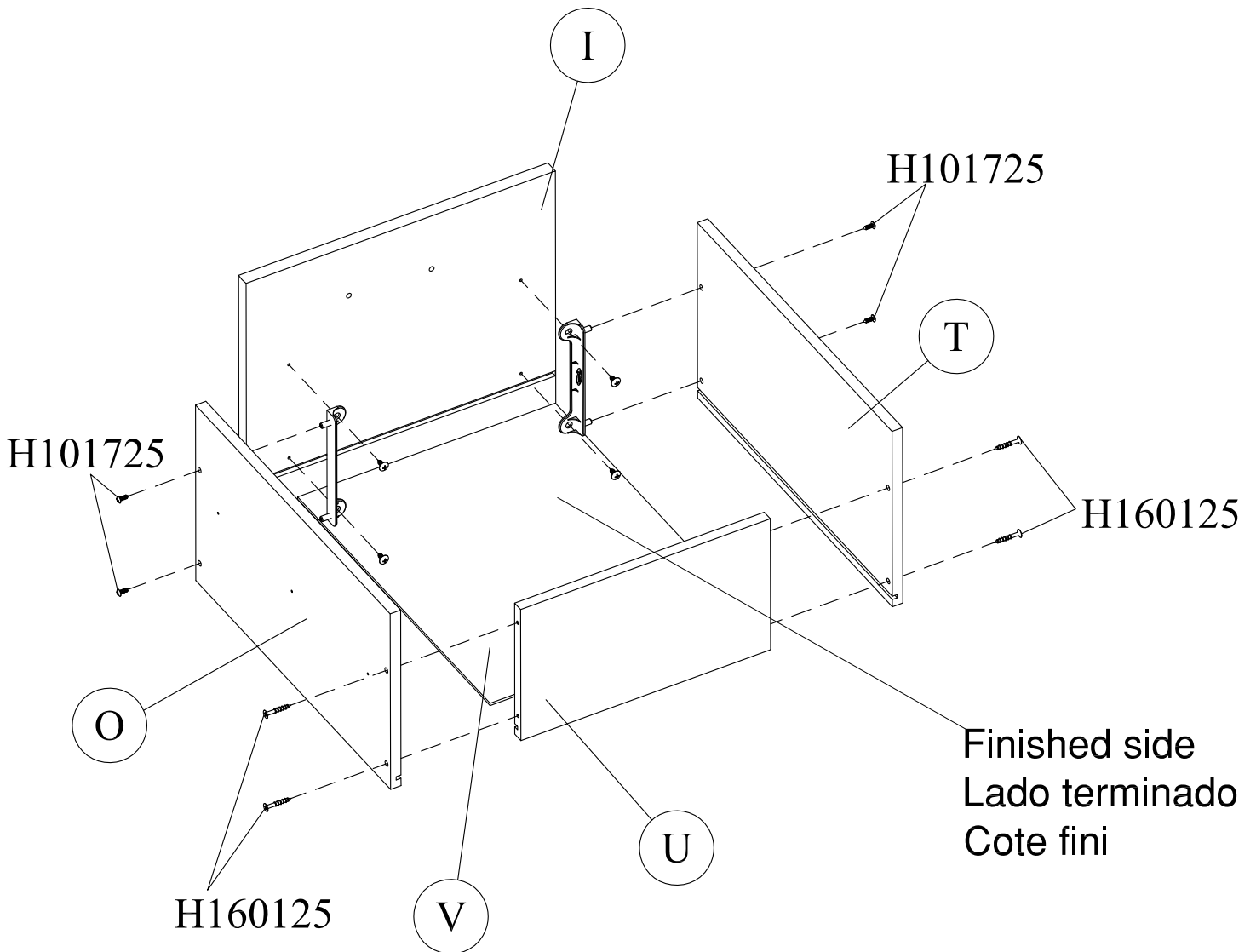

For drawer front adjustment please proceed to step 26.  
 Para ajustes de la parte delantera de las gavetas favor proceda al paso #26.  
 Pour l'ajustement de la façade de tiroir veuillez procéder à l'etape 26.

Z89901  [ 2 ]  
16" Slide (406mm)

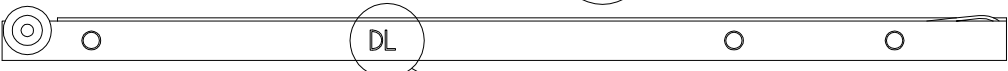
Z89900  [ 2 ]  
16" Slide (406mm)

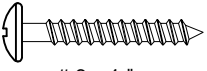
H152964  [ 4 ]  
# 6 x 1 "

H154711  [ 2 ]  
Pull

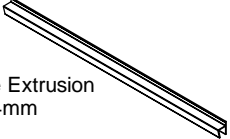
H156859  [ 2 ]  
File Extrusion  
414mm

H124395  [ 12 ]  
#6 x 1/2"

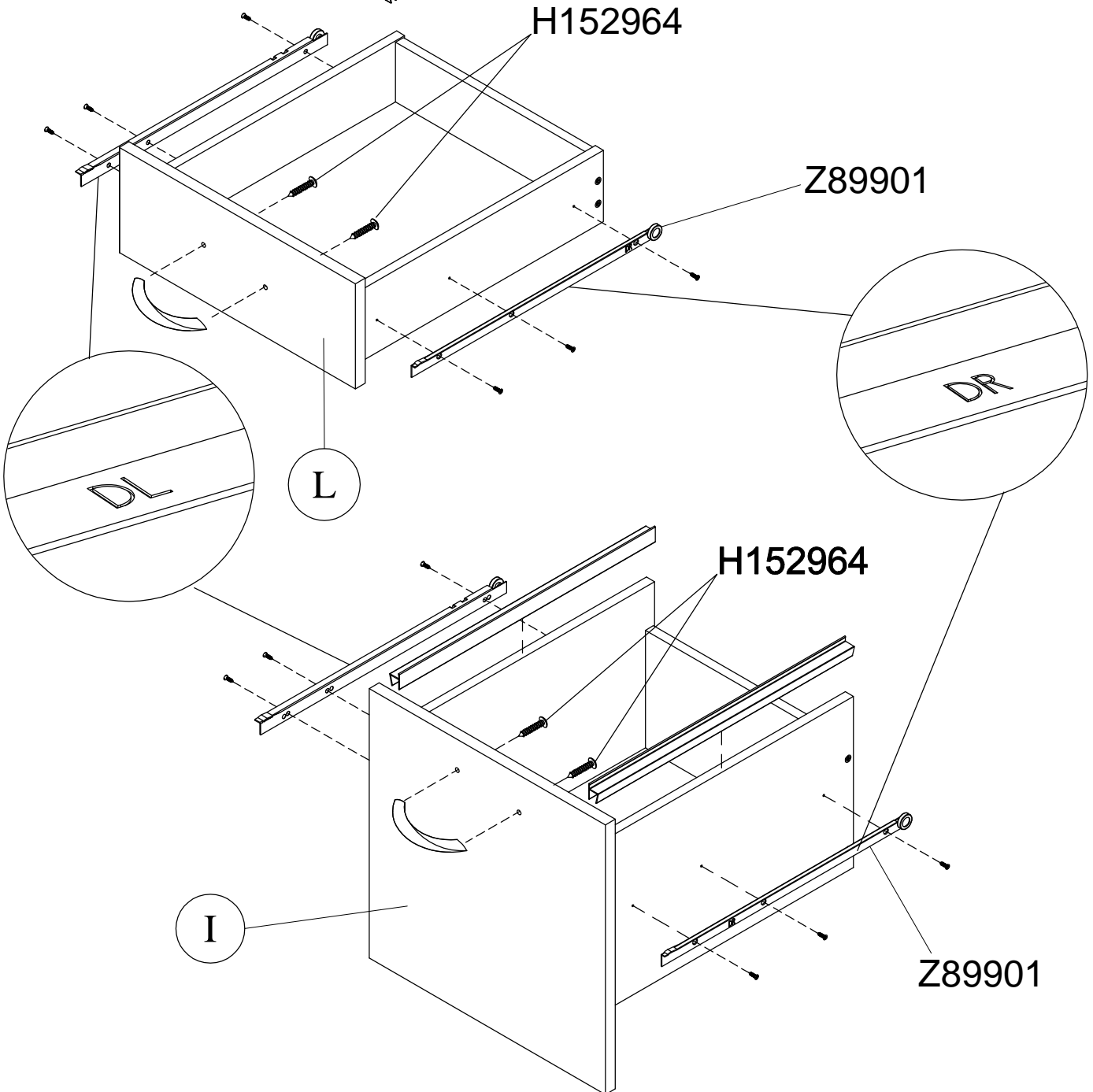

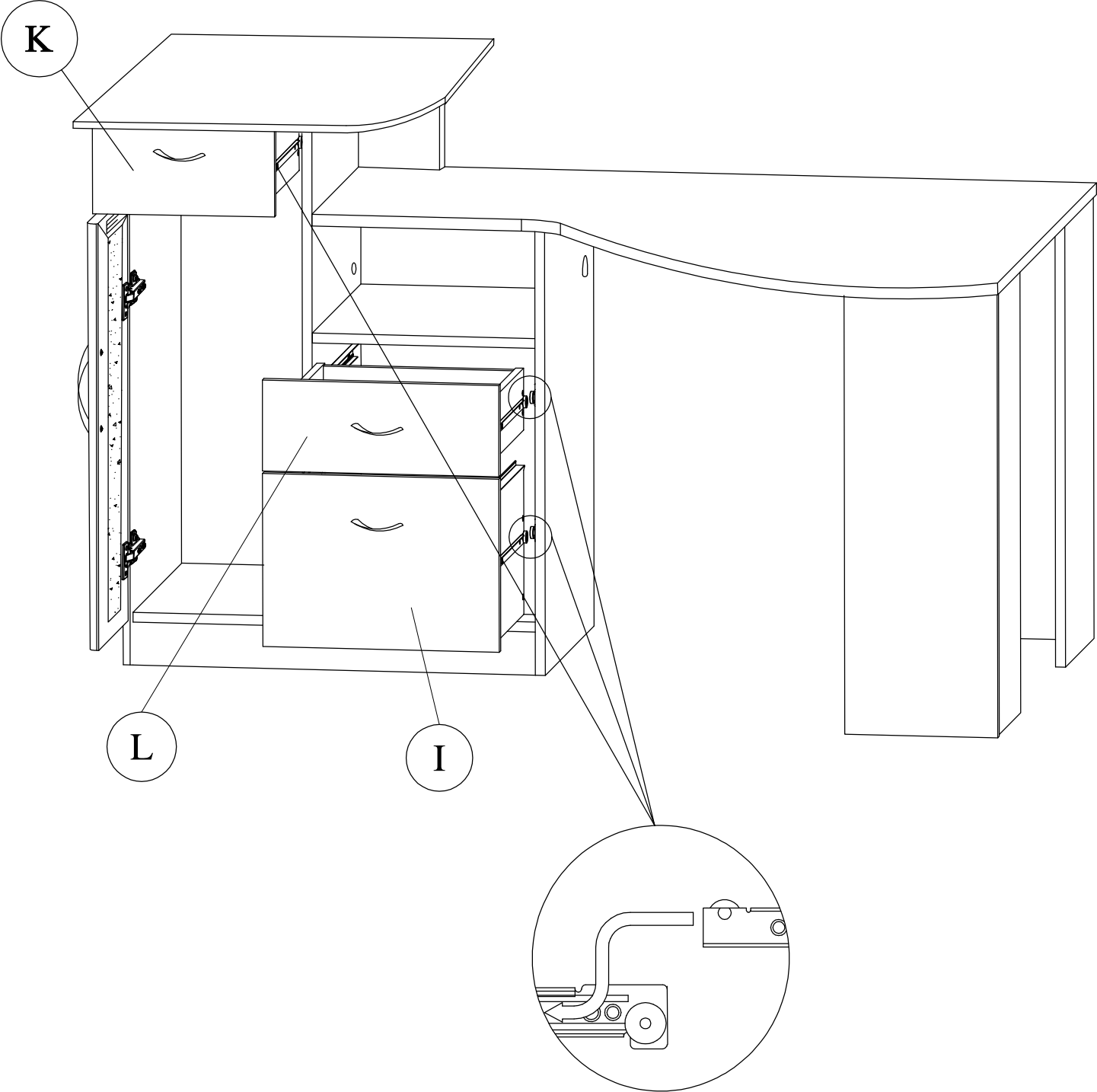

- Move unit to final location.
- Coloque esta unidad en su posición permanente.
- Déplacez l'unité dans l'endroit final.
- Adjust drawer fronts as shown below.
- Ajuste la parte delantera de las gavetas según es indicado.
- Ajustez les façades de tiroir comme montré ci-dessous.

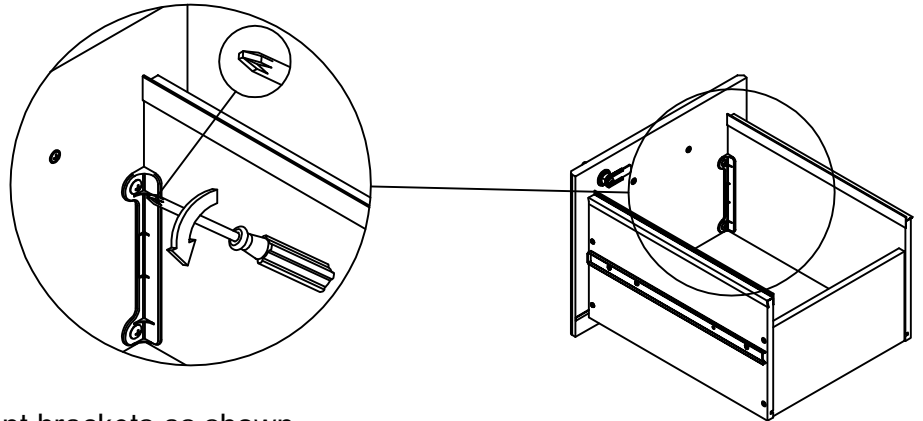

### STEP 1.

Loosen screws on back of drawer front brackets as shown.

Afloje los tornillos en la parte trasera de la gaveta según es indicado.

Desserrez les vis dans les appuis en plastique sur le dos de l'avant de tiroir comme montré.

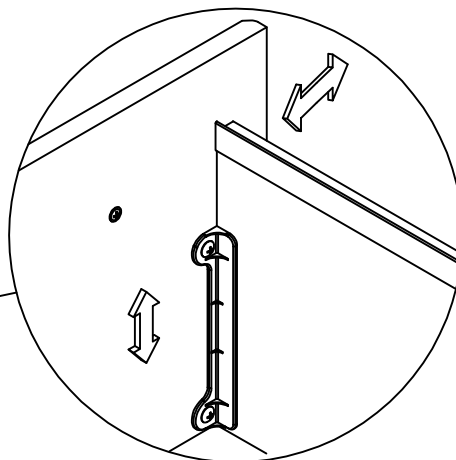

### STEP 2.

Position drawer front as required.

Ajuste la parte delantera de la gaveta según sea necesario.

Placez l'avant de tiroir comme nécessaire.

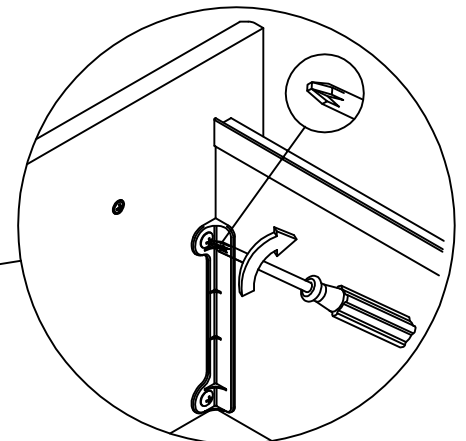

### STEP 3.

Tighten screws while holding drawer front in position.

Apriete los tornillos mientras sujeta la parte delantera de la gaveta en su posición permanente.

Serrez les vis tout en tenant l'avant de tiroir en position.

# WARRANTY INFORMATION/INFORMATIONS POUR LA GARANTIE/INFORMACIÓN DE GARANTÍA

## BUSH FURNITURE'S WRITTEN WARRANTY TO YOU

In order to provide you with timely assistance, please thoroughly inspect your furniture for missing or defective parts immediately after opening the carton. To receive replacement or missing parts under this warranty, call our Consumer Service Department TOLL-FREE at 1-800-950-4782. Please have the Model, Part, and Lot Numbers found in the instruction manual available for your reference. You will also need your sales receipt or other proof of purchase. Replacement part(s) will be shipped to you at no charge with Bush Industries assuming all shipping and handling charges.

This Bush Furniture product is warranted to the original purchaser at the time of purchase and for a period of one year thereafter.

We warrant to you, the original purchaser, that our furniture and all its parts and components are free of defects in material or workmanship. "Defects," as used in this warranty, is defined as any imperfection which impairs the use of the furniture product.

Our warranty is expressly limited to the replacement of furniture parts and components. For one year after the date of purchase, Bush will replace any parts that are defective in material or workmanship.

This warranty applies under conditions of normal use. Our Bush Furniture products are not intended for outdoor use. This warranty does not cover: 1) defects caused by improper assembly or disassembly; 2) defects occurring after purchase due to product modification, intentional damage, accident, misuse, abuse, negligence or exposure to the elements; and 3) labor or assembly costs.

IMPLIED WARRANTIES, INCLUDING THE WARRANTY OF MERCHANTABILITY, SHALL NOT EXTEND BEYOND THE DURATION OF THE WRITTEN WARRANTY STATED ABOVE, AND IN NO EVENT SHALL BUSH BE LIABLE FOR INCIDENTAL OR CONSEQUENTIAL DAMAGES RESULTING FROM USE OF THE PRODUCT. Some states do not allow a limitation on how long an implied warranty lasts or the exclusion or limitation of incidental or consequential damages, so the above limitation and exclusion may not apply to you.

This warranty gives you specific legal rights. You may also have other rights that may vary from state to state.

## VOTRE GARANTIE BUSH FURNITURE

Afin de vous assister rapidement, veuillez inspecter votre mobilier en détail immédiatement après l'ouverture du carton en cas de pièces manquantes ou défectueuses. Pour recevoir une pièce de rechange ou manquante couverte par cette garantie, appelez notre département de service clientèle GRATUITEMENT au 1-800-950-4782. Veuillez tenir à disposition les numéros de modèle, de pièce et de lot qui se trouvent dans le manuel d'instruction pour votre référence. Vous aurez également besoin de votre reçu ou d'une autre preuve d'achat. La (les) pièce(s) de rechange vous sera (seront) envoyée(s) sans frais, Bush Industries se chargeant de tous les frais d'expédition.

Tout le produit Bush Furniture est garanti à l'acheteur original à partir de la date d'achat pour une période d'un an.

Nous vous garantissons, à vous l'acheteur original, que notre mobilier et toutes ses pièces et composants sont sans défaut de matériau ou de fabrication. Le terme "défauts" utilisé dans cette garantie, est défini comme étant toutes les imperfections qui compromettent l'utilisation du meuble.

Notre garantie est expressément limitée au remplacement des pièces et des composants du mobilier. Pendant un an après la date d'achat, Bush remplacera toute pièce défectueuse dans le matériau ou sa fabrication.

Cette garantie d'applique sous des conditions d'utilisation normale. Nos produits ne sont pas destinés à être utilisés en plein air. Cette garantie ne couvre pas: 1) les défauts causés par un mauvais assemblage ou démontage, 2) les défauts ayant lieu après l'achat et dus à la modification du produit, des dommages intentionnels, des accidents, une mauvaise utilisation, un mauvais traitement, la négligence ou l'exposition aux éléments, et 3) les frais de main d'œuvre ou d'assemblage.

LES GARANTIES TACITES, Y COMPRIS LA GARANTIE DE QUALITE MARCHANDE, NE S'ETENDRONT PAS AU-DELA DE LA DUREE ECRITE CITEE CI-DESSUS, ET BUSH NE SERA EN AUCUN CAS RESPONSABLE DES DOMMAGES ACCESSOIRES OU INDIRECTS RESULTANT DE L'UTILISATION DU PRODUIT. Certains états ne permettent pas d'appliquer une limite à la durée de la garantie tacite, ni une exclusion ou limitation des dommages accessoires ou indirects; dans ce cas les limitations ou exclusion ci-dessus peuvent ne pas s'appliquer à vous.

Cette garantie vous donne des droits légaux spécifiques. Il se peut que vous ayez également d'autres droits qui peuvent varier d'un état à l'autre.

## GARANTIA ESCRITA DE BUSH FURNITURE PARA USTED

Para brindarle asistencia oportuna, por favor, verifique detalladamente que a su mueble no le falte o tenga piezas defectuosas inmediatamente después de abrir la caja. Para recibir un reemplazo o la parte faltante bajo esta garantía, llame a nuestro Departamento de Servicio al Consumidor GRATIS al 1-800-950-4782. Sírvase traer los números de modelo, parte y lote que se encuentran en el manual de instrucciones disponible para su referencia. Además, necesitará el recibo de su compra u otra prueba de compra. La(s) pieza(s) de reemplazo le será(n) enviada(s) sin recargo por Bush Industries asumiendo los gastos de envío y manipuleo.

Todo mueble de Bush Furniture es garantizado al comprador original al momento de la compra y por un periodo de uno año en adelante.

Le garantizamos a usted, el comprador original, que nuestros muebles sus partes y componentes están libres de defectos en materiales o trabajo. "Defectos", según se usa en esta garantía, se define como una imperfección que perjudica el uso del producto mobiliario.

Nuestra garantía se limita expresamente al reemplazo de partes y componentes mobiliarios. Durante uno año después de la fecha de compra, Bush reemplazará cualquier parte defectuosa en material o trabajo.

Esta garantía se aplica bajo condiciones de uso normal. Nuestros productos de Bush Furniture no son para uso en exteriores. Esta garantía no cubre: 1) defectos causados por un ensamblaje o desensamblaje inadecuado; 2) defectos que ocurran después de la compra debido a modificación del producto, daño intencional, accidente, mal uso, abuso, negligencia o exposición a los elementos; y 3) costos de trabajo o ensamblaje.

LAS GARANTÍAS IMPLICADAS, INCLUYENDO LA GARANTÍA DE COMERCIABILIDAD, NO SE EXTENDERÁN MÁS ALLÁ DE LA DURACIÓN DE LA GARANTÍA ESCRITA MENCIONADA, Y EN NINGÚN CASO BUSH SERÁ RESPONSABLE POR DAÑOS INCIDENTALES O CONSIGUIENTES COMO RESULTADO DEL USO DEL PRODUCTO. Algunos estados no permiten una limitación sobre el tiempo de duración de la garantía implicada o la exclusión o limitación de daños incidentales o consiguientes, de manera que la limitación y exclusión mencionadas pueden no aplicarse para usted.

Esta garantía le otorga derechos legales específicos. Puede también tener otros derechos que pueden variar según los estados.

**1-Year**  
Manufacturer's  
Warranty

**REGISTER YOUR PRODUCT ONLINE AT**  
<http://www.bushfurniture.com/ProductRegistration.aspx>