

# ASSEMBLY INSTRUCTIONS

---

## Bookcase

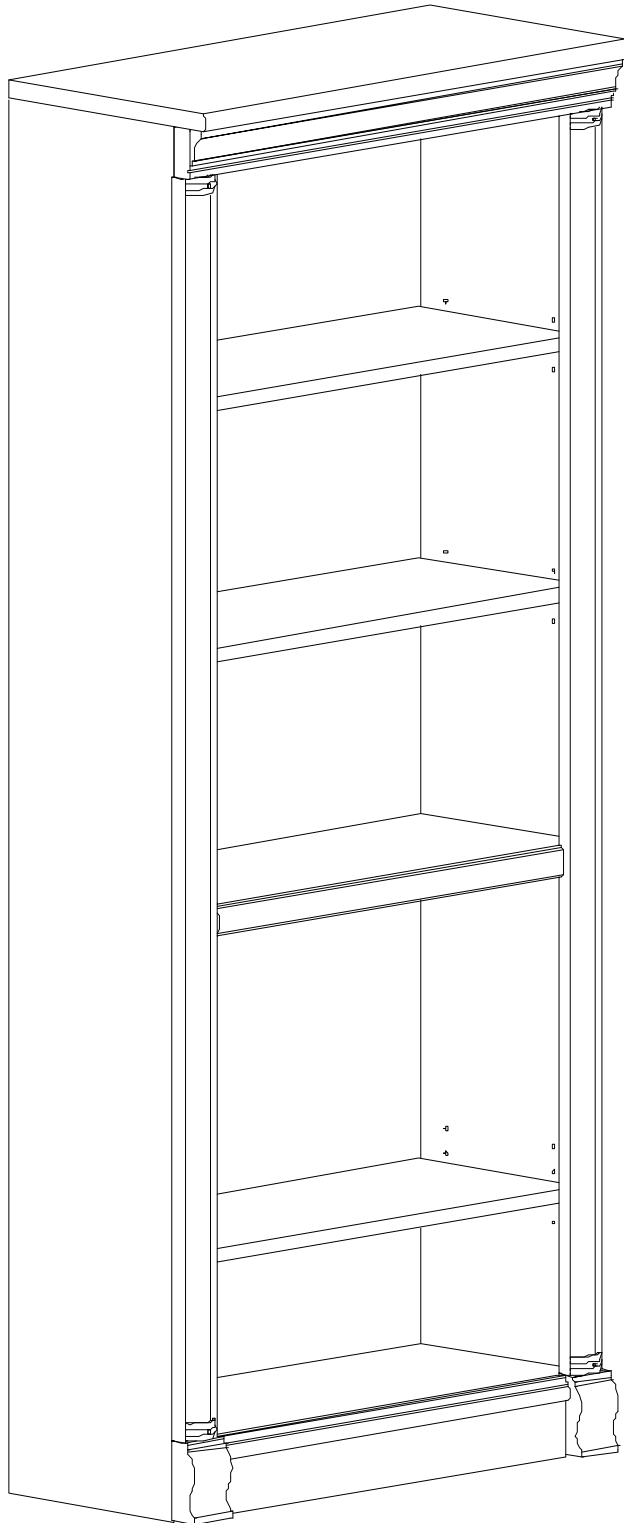

NEED HELP?  
Call 1-800-950-4782  
[www.bushfurniture.com](http://www.bushfurniture.com)

Lot Code #

---

Part Number A174824B

Keep manual for future reference.

# Bush<sup>®</sup>

## FURNITURE

**Thank you for purchasing** this Bush Furniture product. We trust that you will be completely satisfied with your product for many years to come. Bush Furniture products are backed by a 6-year warranty and crafted with today's styles in mind for the way you work. **Do not return product to store — contact us first at 1-800-950-4782.**

**Merci d'avoir acheté** ce produit Bush Furniture. Nous sommes sûr que vous serez complètement satisfait de votre meuble pendant de nombreuses années. Les produits Bush Furniture sont garantis pendant 6 ans et sont conçus dans les styles actuels tout en gardant à l'esprit votre façon de travailler. **Ne renvoyez pas le produit au magasin, contactez-nous d'abord au 1-800-950-4782.**

**Gracias por comprar** este producto de Bush Furniture. Confiamos que usted estará completamente satisfecho con su mueble por muchos años. Los productos de Bush Furniture tienen 6 años de garantía y son diseñados con los estilos de hoy en mente para la manera que usted vive. **No devuelva el producto a la tienda, primero comuníquese con nosotros al 1-800-950-4782.**

## CONTACT US

Monday – Friday  
8:30 a.m. – 7:30 p.m. ET  
(Except Holidays)

Bush Consumer Services  
One Mason Drive, P.O. Box 460  
Jamestown, NY 14701  
ConsumerService@Bushindustries.com

**1-800-950-4782 USA/CANADA**  
**001-800-950-4782 MEXICO**

Se habla español  
Outside USA/CANADA/MEXICO  
001-716-665-2510 Ext. 4514

## IT'S AS EASY AS 1,2,3

### Assembly tips:

1. Read the instructions and become familiar with the parts.
2. Ensure this carton contains all parts, fasteners and hardware.
3. To protect floors, assemble the furniture on the carton.
4. An assistant may be helpful.
5. Use of power tools is not recommended.

### Conseils d'assemblage:

1. Lisez les instructions et familiarisez-vous avec les pièces.
2. Assurez-vous que le carton contient toutes les pièces, toutes les pièces de fixation et toute la quincaillerie.
3. Pour protéger vos sols, assemblez le meuble sur le carton.
4. Il peut être utile de vous faire aider.
5. L'utilisation d'outils électriques n'est pas recommandée.

### Consejos de Ensamblaje:

1. Lea las instrucciones y familiarícese con las partes.
2. Asegúrese de que esta caja contenga todas las piezas, los sujetadores y el equipo.
3. Para proteger el piso, ensamble el mueble en el carton.
4. Un asistente puede serle útil.
5. El uso de herramientas eléctricas no se recomienda.



## CONSUMER SERVICE

### YOU CAN DEPEND ON

**Questions?** Operators are standing by at our TOLL-FREE help line to assist you with assembly; and, if necessary, to quickly replace damaged/missing parts. Assistance is available 5 days a week. Simply have your store receipt, instruction manual, and part number/description ready when you call our TOLL-FREE help line. It's that easy.

UN SERVICE CLIENTELE SUR LEQUEL VOUS POUVEZ COMPTER  
**Des questions?** Des opérateurs sont prêts sur notre ligne d'assistance GRATUITE pour vous aider à l'assemblage et, si nécessaire, remplacer rapidement les pièces endommagées/manquantes. L'assistance est disponible 5 jours par semaine. Ayez simplement votre reçu de magasin, votre manuel d'instruction et le numéro de pièces/description à votre disposition lorsque vous appelez notre ligne d'assistance GRATUITE. C'est aussi simple que ça.

SERVICIO AL CONSUMIDOR CON EL QUE PUEDE CONTAR  
**¿Preguntas?** Los operadores están listos para ayudarlo con el ensamblaje a través de una línea de ayuda GRATUITA, y en caso de ser necesario, reemplazar de inmediato las piezas dañadas o faltantes. La asistencia está disponible los 5 días de la semana. Solamente tenga listos su recibo de compra, manual de indicaciones y número/descripción de la pieza al momento de llamarnos a la línea de ayuda GRATUITA. Es así de sencillo.

[www.bushfurniture.com](http://www.bushfurniture.com)

**WARNING**

DO NOT LOAD UNIT WITHOUT PROPERLY ATTACHING BACK PANEL. DOING SO COULD CAUSE INSTABILITY, PRODUCT COLLAPSE, AND/OR SERIOUS INJURY.

---

NO CARGUE ESTA UNIDAD SIN EL PANEL DE ATRÁS. HACERLO PUEDE CAUSAR INESTABILIDAD, QUE EL PRODUCTO SE DERRUMBE, Y/O HERIDAS (GOLPES) SERIAS.

---

NE PAS CHARGER LE PRODUIT SANS ATTACHER CORRECTEMENT LE PANNEAU ARRIÈRE. FAIRE AINSI PEUT CAUSER L'INSTABILITÉ OU L'EFFONDREMENT DU PRODUIT ET PEUT VOUS CAUSER DES ENDOMMAGEMENTS SÉRIEUX.

**WARNING**

REMOVE ALL ITEMS FROM SHELVES BEFORE MOVING OR LIFTING.

---

RETIRE TODOS LOS ARTÍCULOS DE LOS ESTANTES ANTES DE MOVER O LEVANTAR OBJETOS.

---

RETIREZ TOUS LES ÉLÉMENTS ÉTAGÈRES AVANT DE SE DÉPLACER OU DE LEVAGE



## WARNING

Serious or fatal crushing injuries can occur from furniture tip-over. To help prevent tip-over:

- Install tip-over restraint provided.
- Place heaviest items in the lower drawers or shelves.
- Unless specifically designed to accommodate, do not set TVs or other heavy objects on top of this product.
- Never allow children to climb or hang on drawers, doors or shelves.
- Never open more than one drawer at a time.
- Use of tip-over restraints may only reduce, but not eliminate, the risk of tip-over.

Lesiones por aplastamiento graves o fatales pueden ocurrir desde muebles vuelco. Para ayudar a prevenir que vuelque:

- Instale que vuelque resistente proporcionado.
- Coloque los artículos más pesados en los cajones inferiores o estantes.
- A menos que específicamente diseñado para dar cabida, no establezca televisores u otros objetos pesados encima de este producto.
- Nunca permita que los niños se suban o se cuelguen de los cajones, puertas o estantes.
- Nunca abra más de un cajón a la vez.
- El uso de sistemas de retención de punta sobre sólo podrá reducir, pero no eliminar, el riesgo de vuelco.

Des blessures par écrasement graves ou mortelles peuvent se produire des meubles renversement. Pour aider à prévenir un renversement:

- Installez sur la pointe résistant fourni.
- Placez les articles les plus lourds dans les tiroirs inférieurs ou des étagères.
- Sauf spécifiquement conçu pour accueillir, ne réglez pas les téléviseurs ou d'autres objets lourds sur ce produit.
- Ne jamais laisser les enfants grimper ou de se pendre tiroirs, portes ou des étagères.
- Ne jamais ouvrir plus d'un tiroir à la fois.
- Utilisation de la contention de renversement ne peut réduire, mais non éliminer, le risque de renversement.

Verify that furniture is stable on its own. For added security, anchor to the wall using hardware provided.

Verifique que los muebles son estables por sí solo. Para mayor seguridad, anclaje a la pared con el hardware proporcionado.

Vérifiez que le mobilier est stable sur son propre. Pour plus de sécurité, ancrage au mur en utilisant le matériel fourni.

Avoid leaving items that might tempt kids to climb, such as toys and remote controls, from the top of furniture.

Evite los artículos dejando que podrían tentar a niños a subir, como juguetes y controles remotos, desde la parte superior de los muebles

Évitez les articles sortant qui pourraient tenter les enfants de grimper, comme les jouets et les télécommandes, du haut de meubles

**MAXIMUM WEIGHT: 0 LBS (0 KG)**  
**PESO MÁXIMO: 0 LIBRAS (0 KILOGRAMO)**  
**POIDS MAXIMUM: 0 LIVRES (0 KILOGRAMME)**

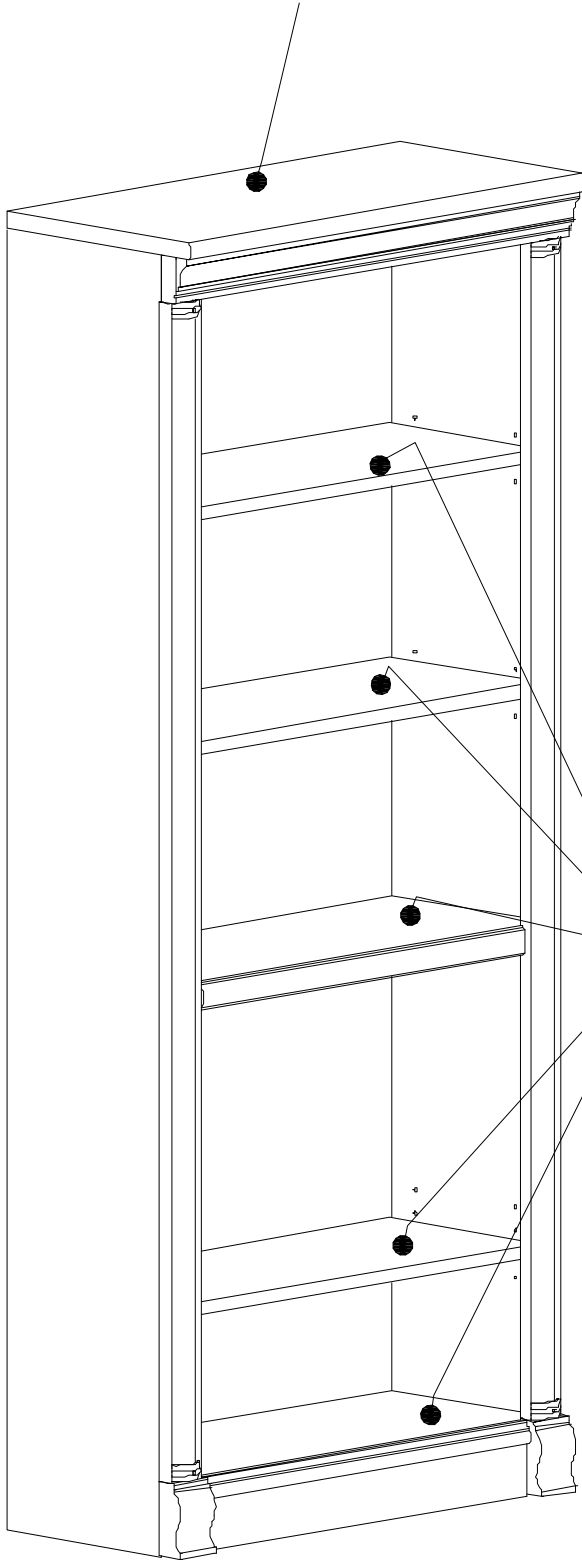

**MAXIMUM WEIGHT: 30 LBS (13.5 KG)**  
**PESO MÁXIMO: 30 LIBRAS**  
**(13.5 KILOGRAMO)**  
**POIDS MAXIMUM: 30 LIVRES**  
**(13.5 KILOGRAMME)**

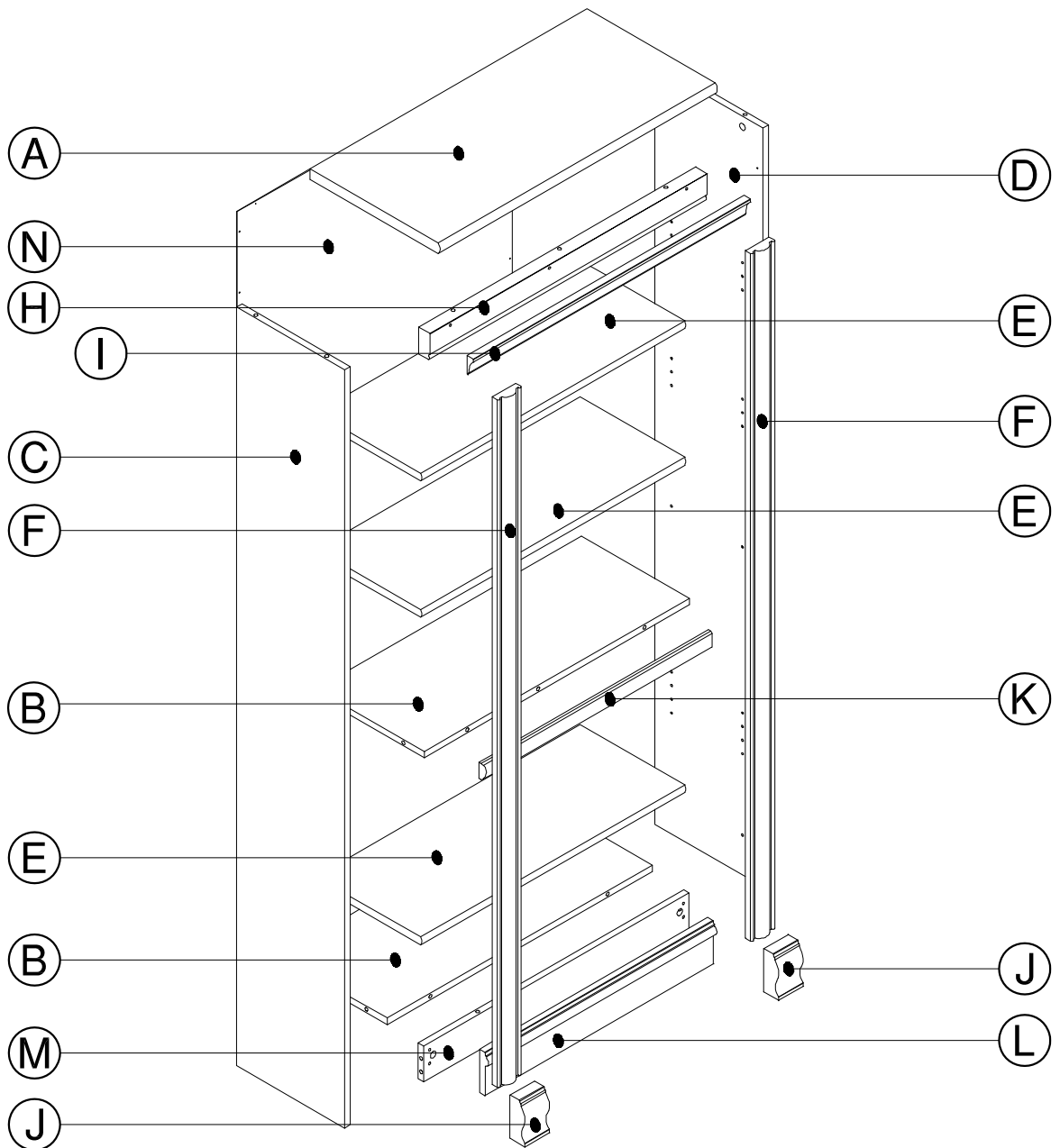

## WL26665

A	[1]	W156861	I	[1]	W156868
B	[2]	W156862	J	[2]	W156869
C	[1]	W156863	K	[1]	W156870
D	[1]	W156864	L	[1]	W156871
E	[3]	W156865	M	[1]	W156872
F	[2]	W156866	N	[1]	W156873
H	[1]	W156867			

## WL26965

A	[1]	W174876	I	[1]	W174883
B	[2]	W174877	J	[2]	W174884
C	[1]	W174878	K	[1]	W174885
D	[1]	W174879	L	[1]	W174886
E	[3]	W174880	M	[1]	W174887
F	[2]	W174881	N	[1]	W174888
H	[1]	W174882			



Fasteners are shown in actual size.

Los fijadores son demostrados en su tamaño actual.

Les attaches sont montrées dans l'échelle grandeur.

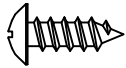
**H43507**Quantity  
**20**

#8 x 1/2"

**H156851**Quantity  
**4**

#10 x 1"

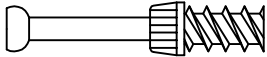
**H159917**Quantity  
**23**

KD Bolt

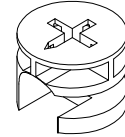
**H159916**Quantity  
**23**

KD Cam

**H23468**Quantity  
**3**

#10 x 1-1/2"

**H38169**Quantity  
**3**

Wood Dowel 8 x 30mm

**H34174**Quantity  
**47**

#3 x 3/4"

**H156875**Quantity  
**4**

1.5 x 19mm

H27145

Quantity  
**1**

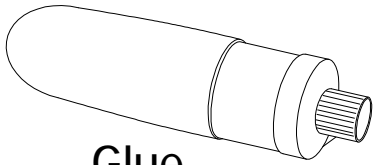

Glue

H20385

Quantity  
**4**



Tack Glide

H67866

Quantity  
**12**

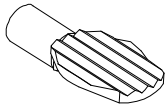

Shelf Pin

H156903

Quantity  
**10**

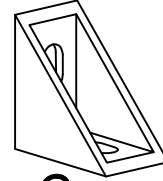

Plastic Connector

WL26665

H156904

Quantity  
**4**

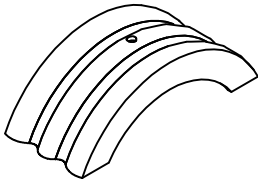

Decorated

WL26965

H174933

Quantity  
**4**

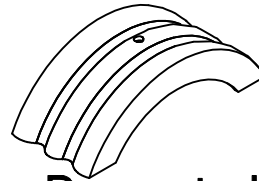

Decorated

H158961

Quantity  
**4**

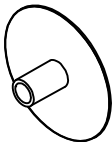

Cover Cap

H160173

Quantity  
**4**



Cover Cap

# Q181420

H181434

Quantity  
**1**

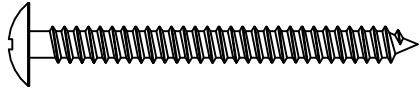

#10x2"

H145191

Quantity  
**1**



#8 x 3/4"

H181419

Quantity  
**1**

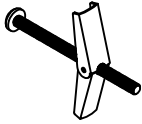

Toggle Bolt

H181412

Quantity  
**2**

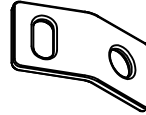

Connecting Plate

H181411

Quantity  
**1**



Nylon Cable Tie

Common assembly techniques.  
Técnica común de ensamblaje.  
Techniques communes d'assemblage.

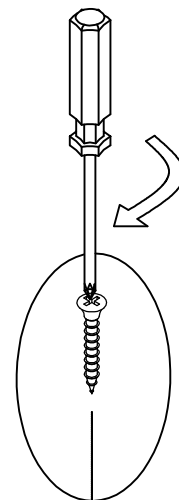
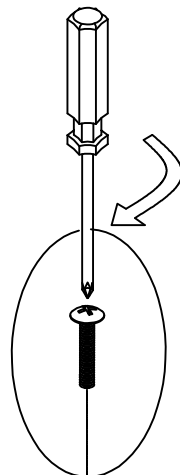
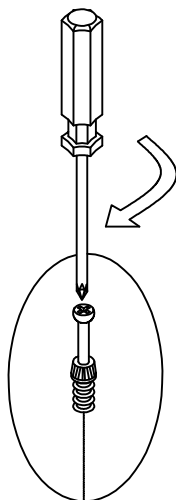
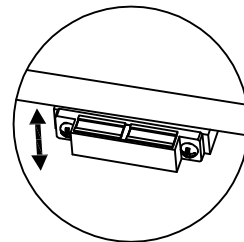
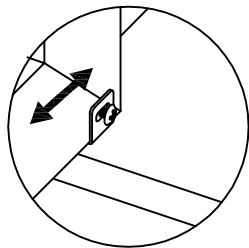
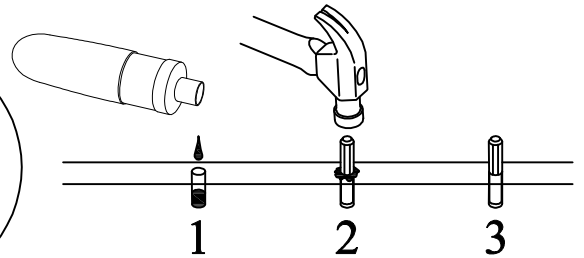
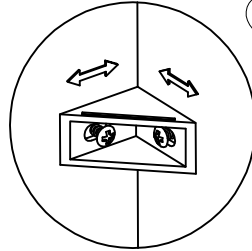
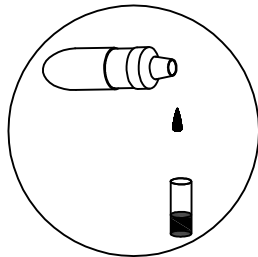
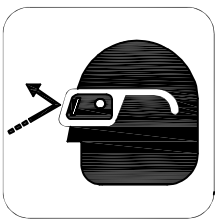
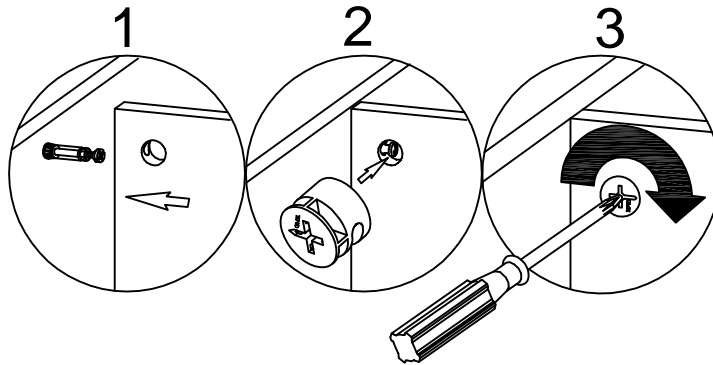

H159917

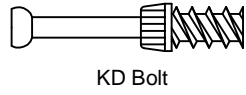

[ 10 ]

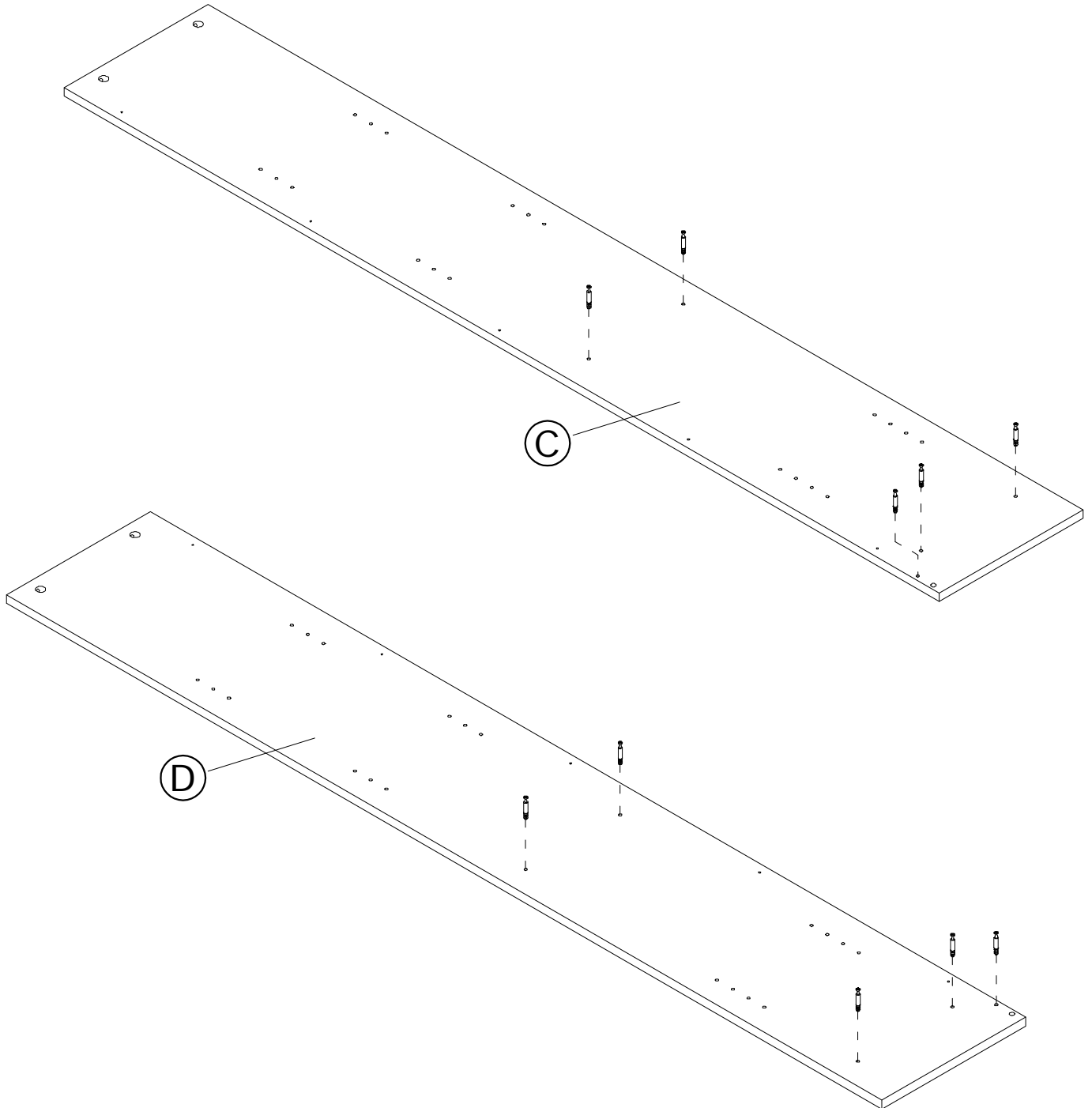

H159917

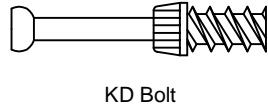

[ 13 ]

H27145

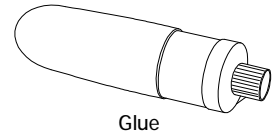

H38169



[ 3 ]

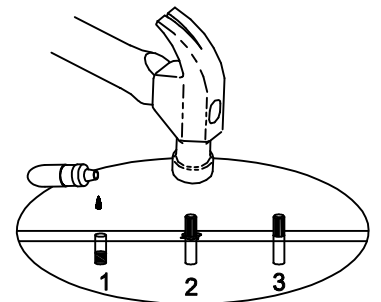
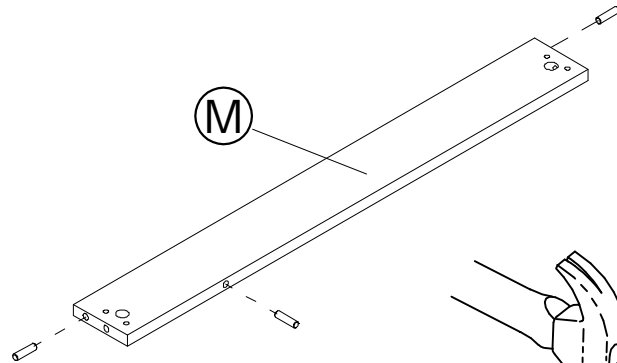
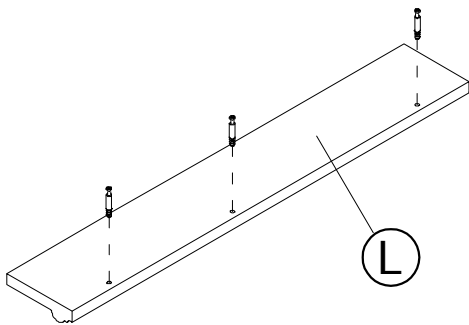
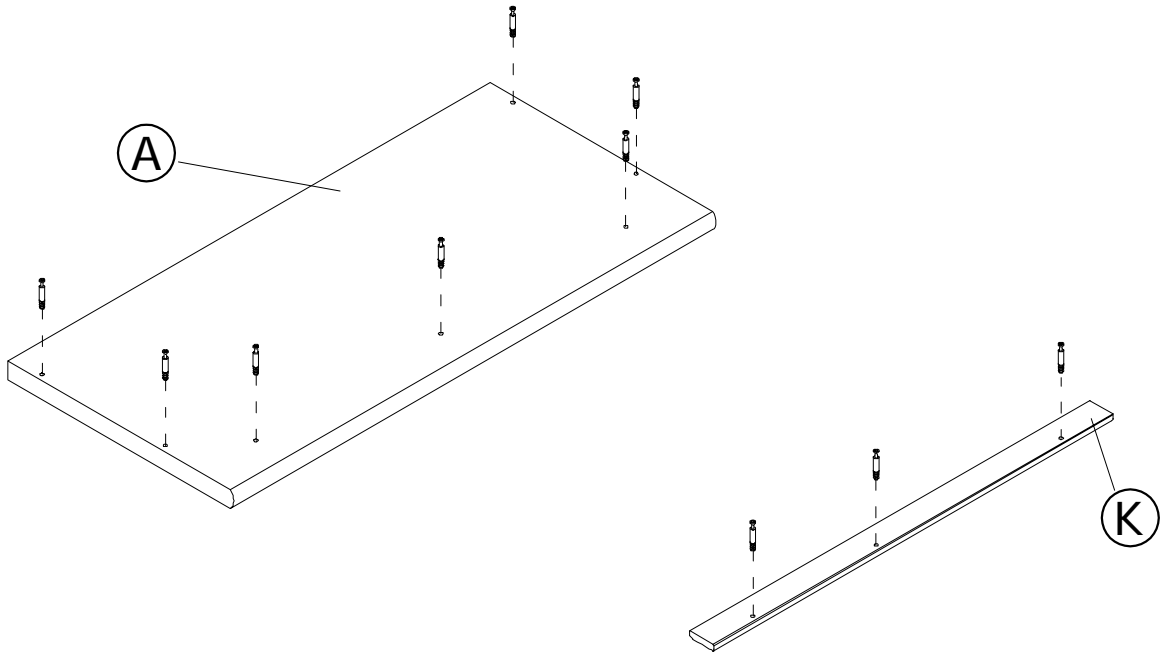

H23468

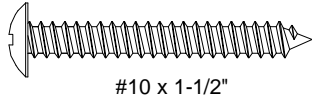

#10 x 1-1/2"

[ 3 ]

H27145

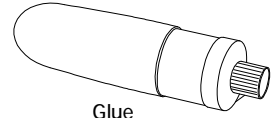

Glue

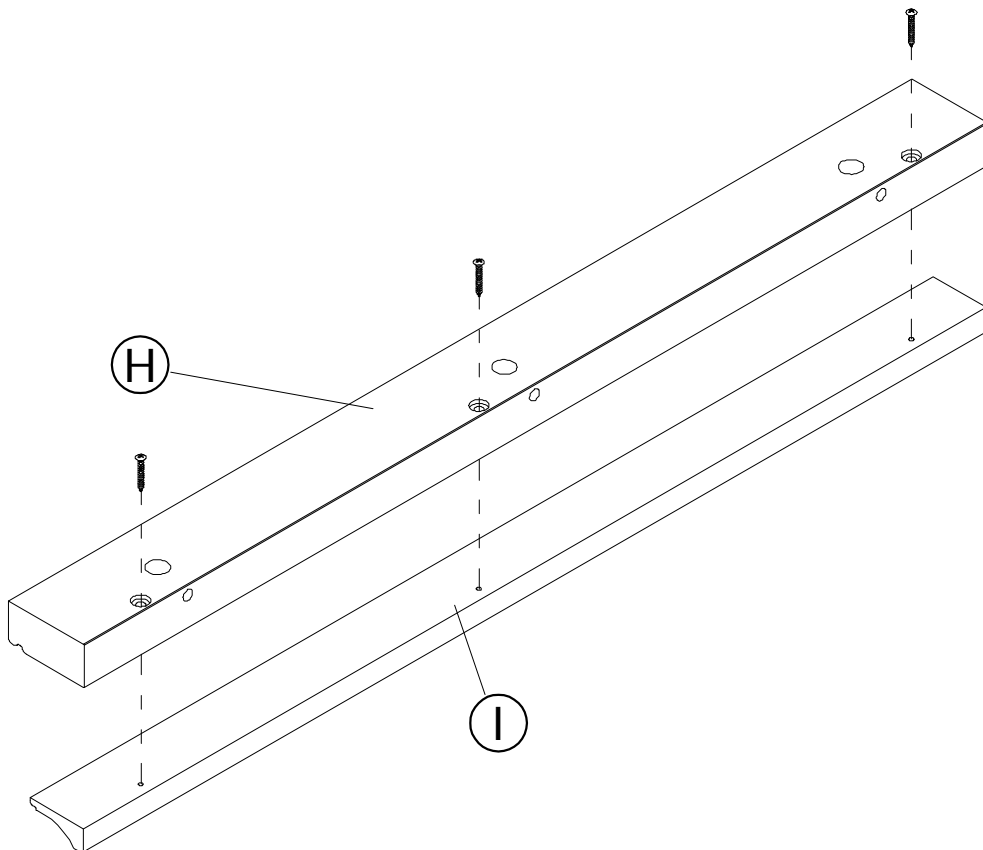
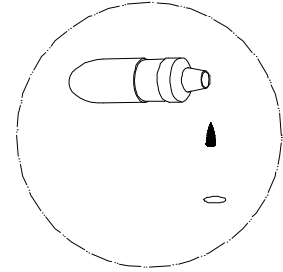
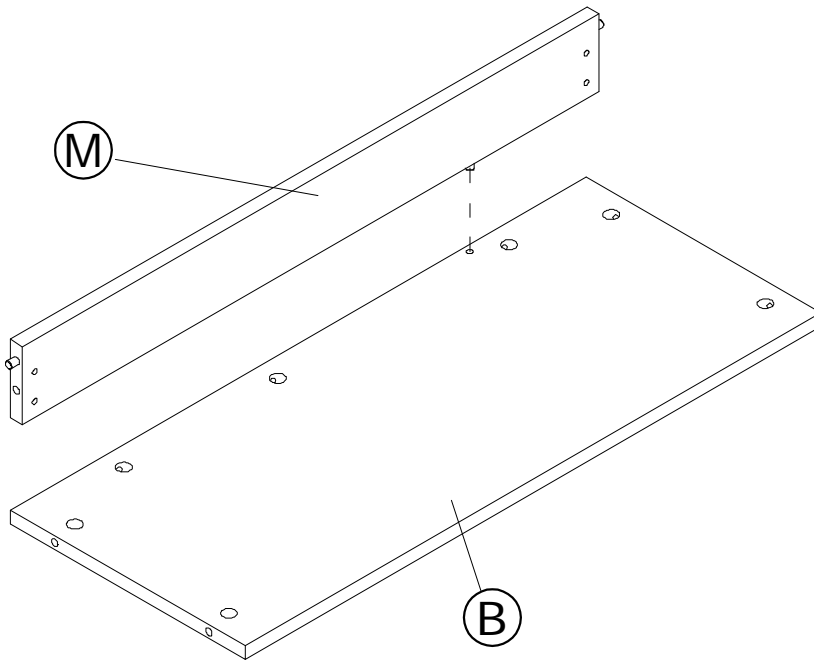

H159916

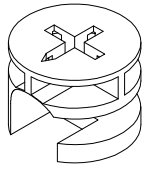

KD Cam

[ 5 ]

H27145

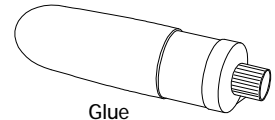

Glue

An assistant is required.  
Es necesario un ayudante.  
Un assistant est nécessaire.

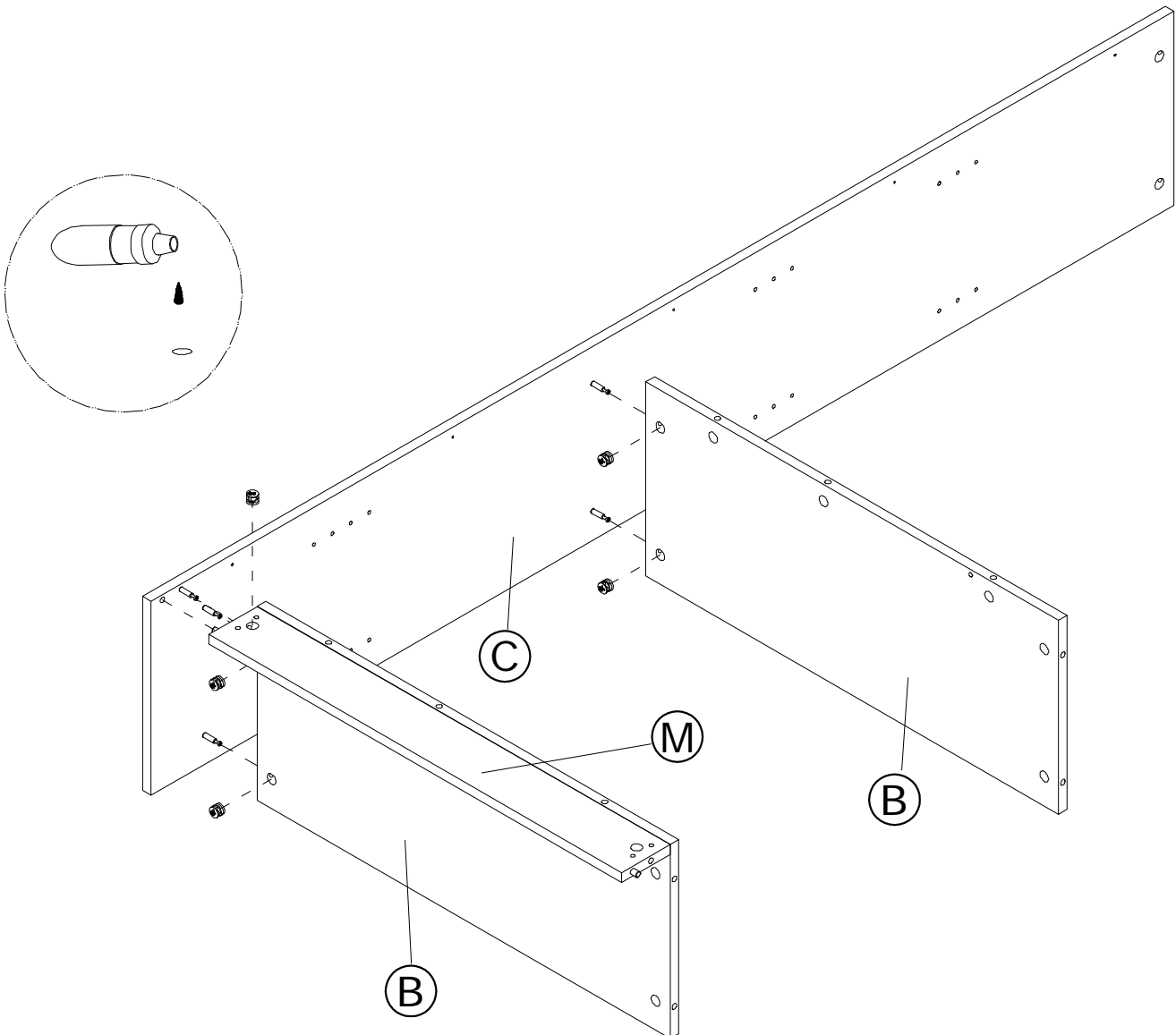



H159916

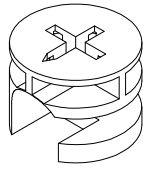

KD Cam

[ 5 ]

H27145

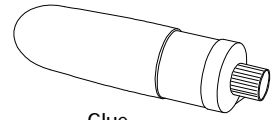

Glue

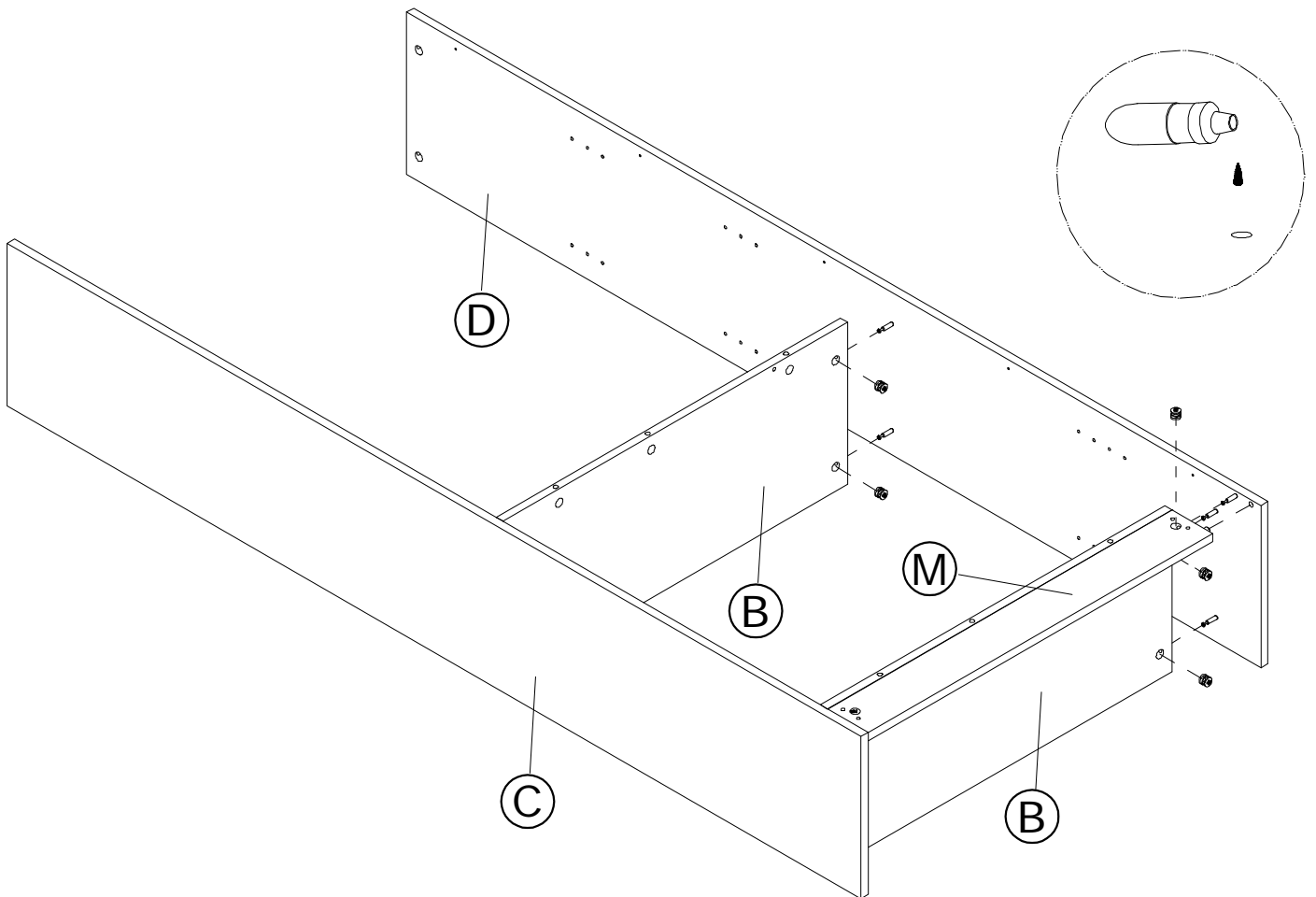

H159916

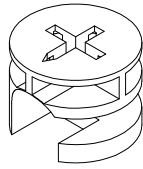

KD Cam

[ 6 ]

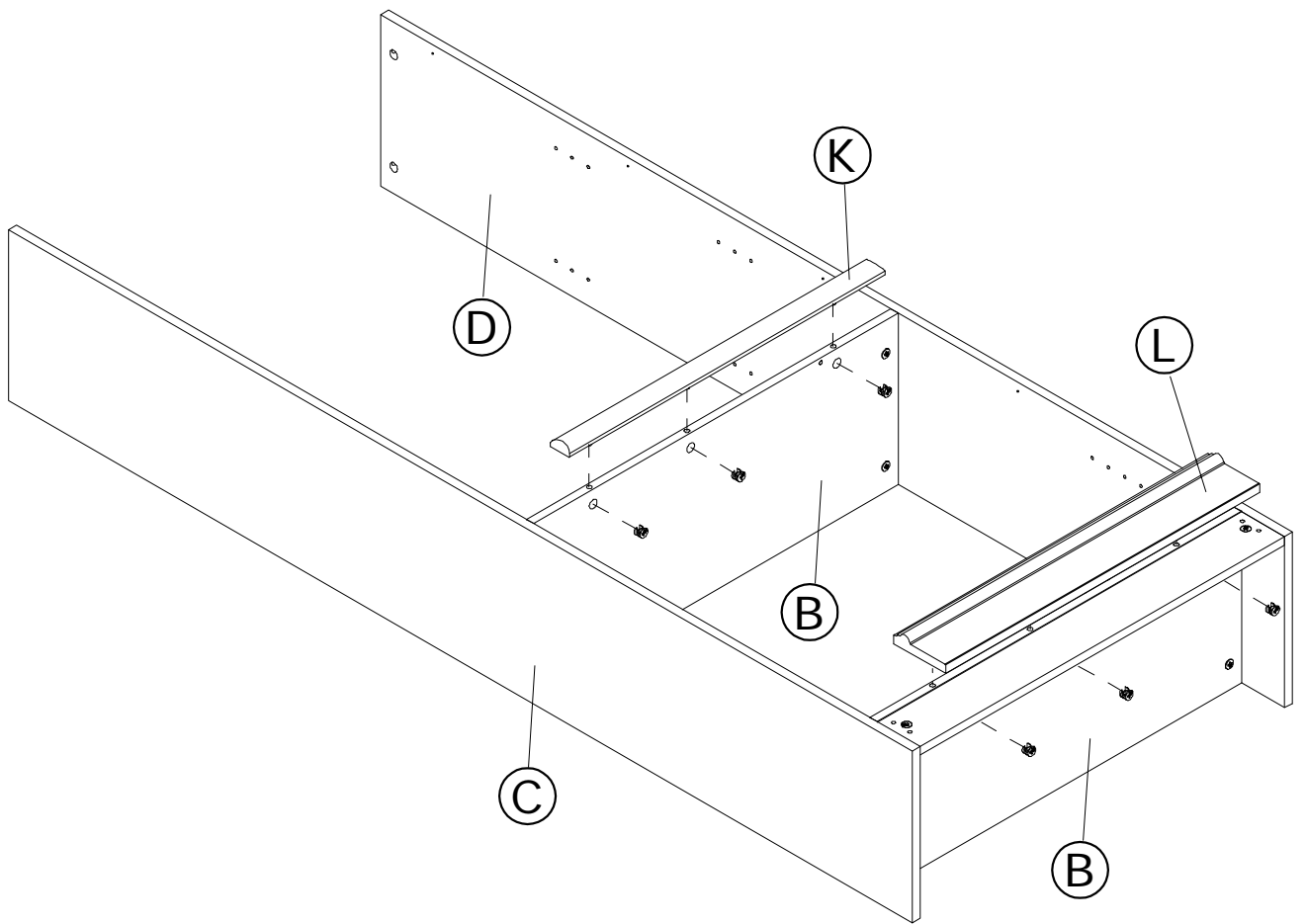

H159916

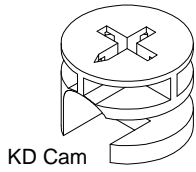

[ 3 ]

H156903

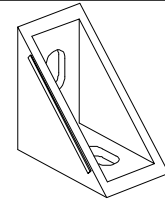

Plastic Connector

[ 10 ]

WL26665

H156904

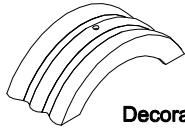

Decorated

[ 4 ]

H43507



#8 x 1/2"

[ 10 ]

H156875

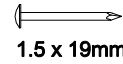

1.5 x 19mm

[ 4 ]

WL26965

H174933

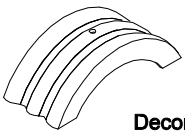

Decorated

[ 4 ]

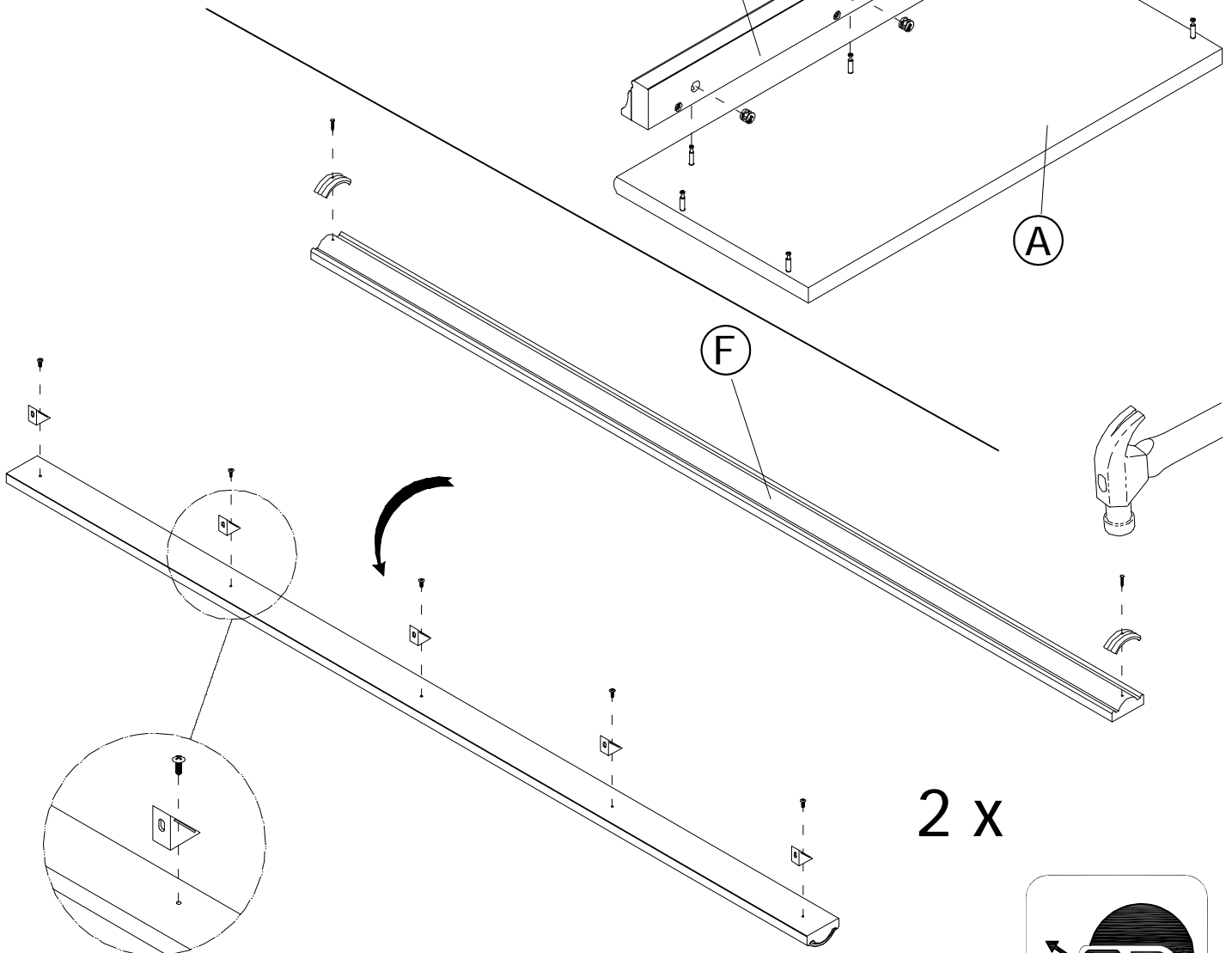
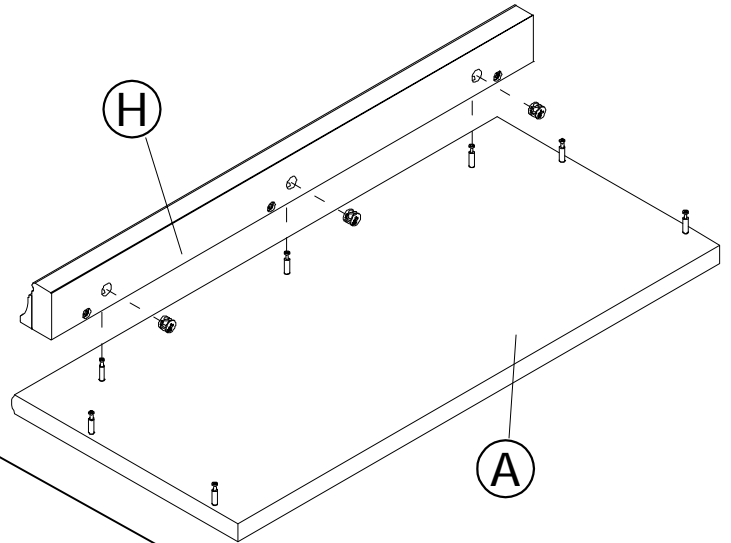

2 x

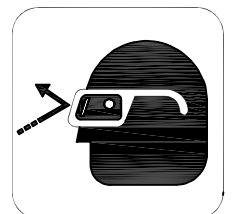

**H158961**  **[ 4 ]**  
Cover Cap  
**WL26665**

**H160173**  **[ 4 ]**  
Cover Cap  
**WL26965**

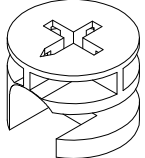
**H159916**  **[ 4 ]**  
KD Cam

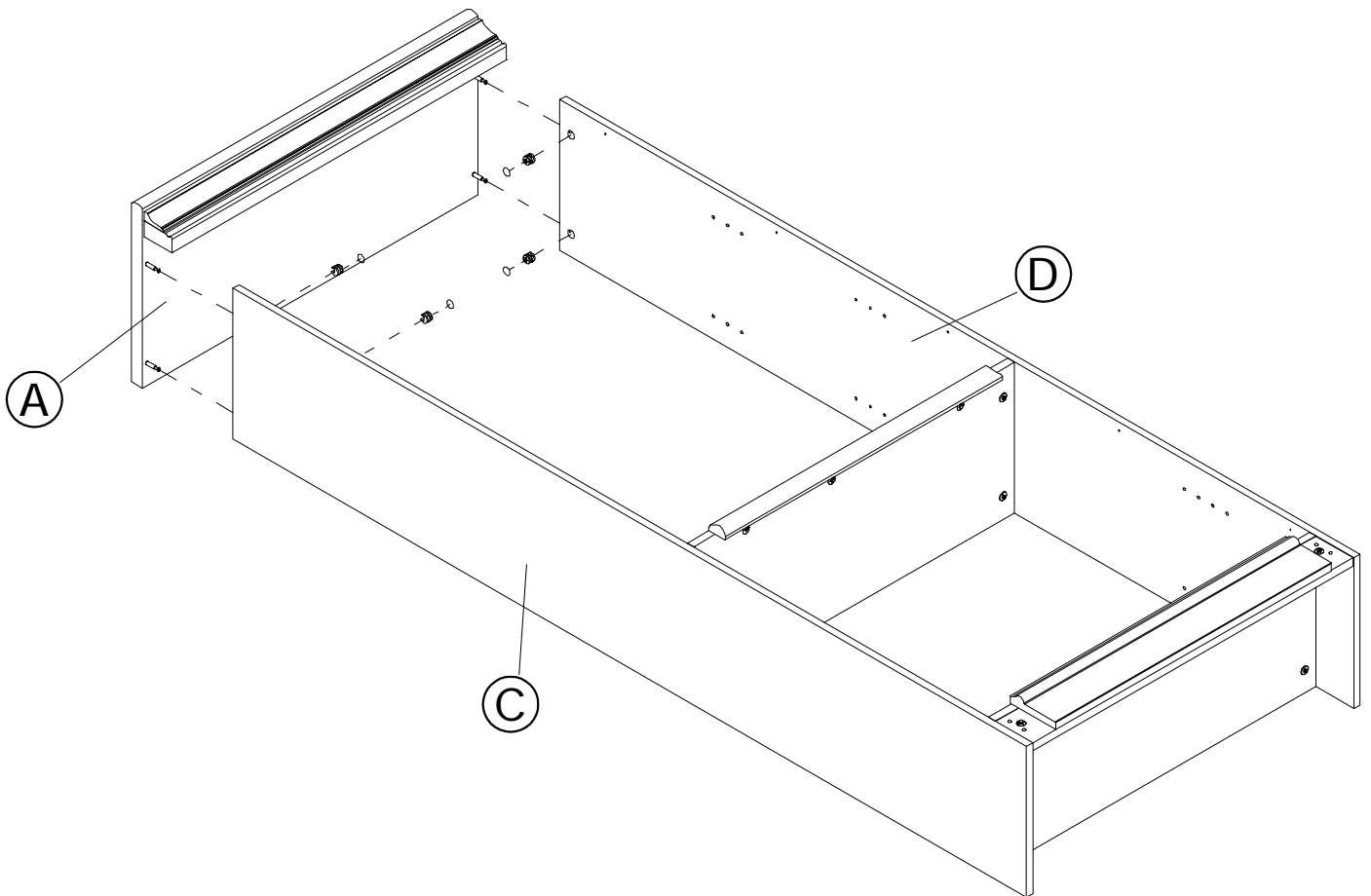

H156851

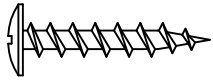

#10 x 1"

[ 4 ]

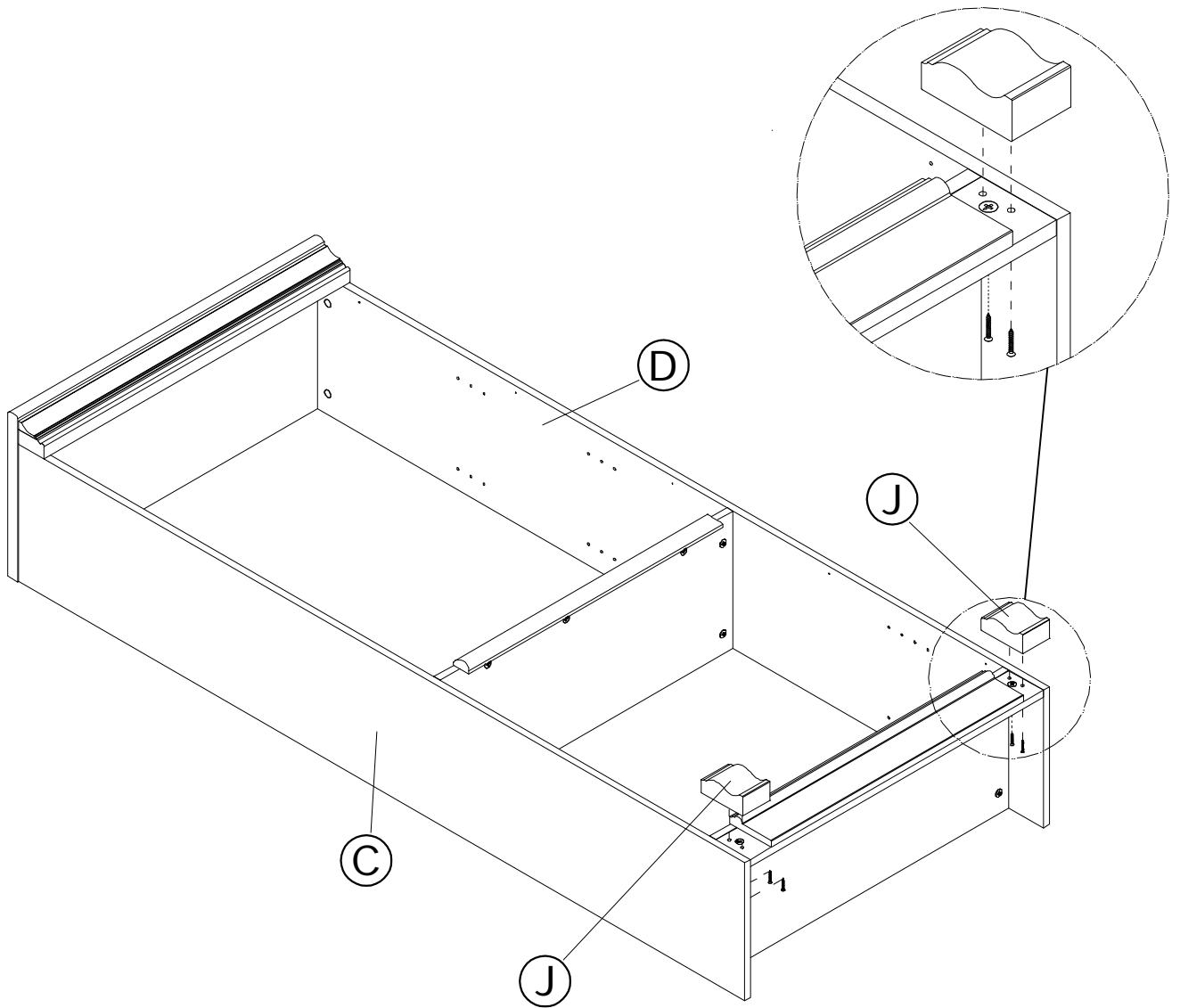

H43507

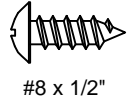

[ 10 ]

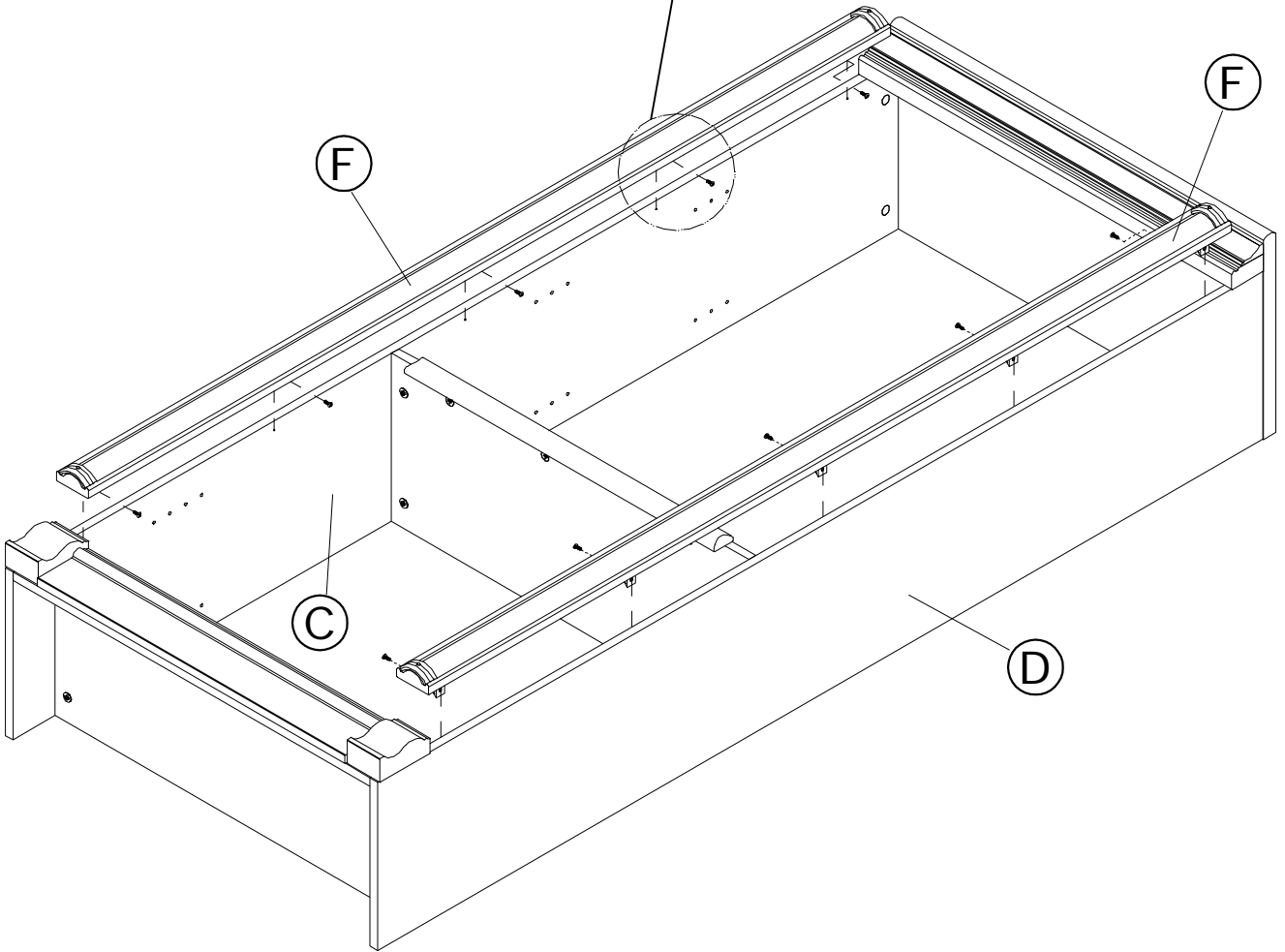
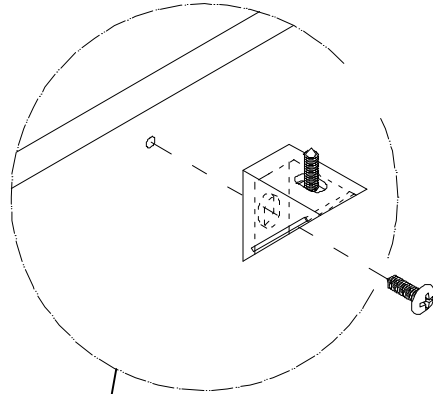
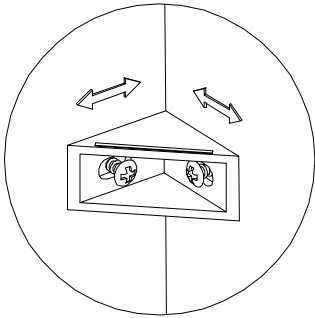

H34174

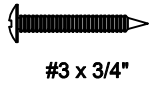

[ 47 ]

H20385



[ 4 ]

Tack Glide



An assistant is required.  
Es necesario un ayudante.  
Un assistant est nécessaire.

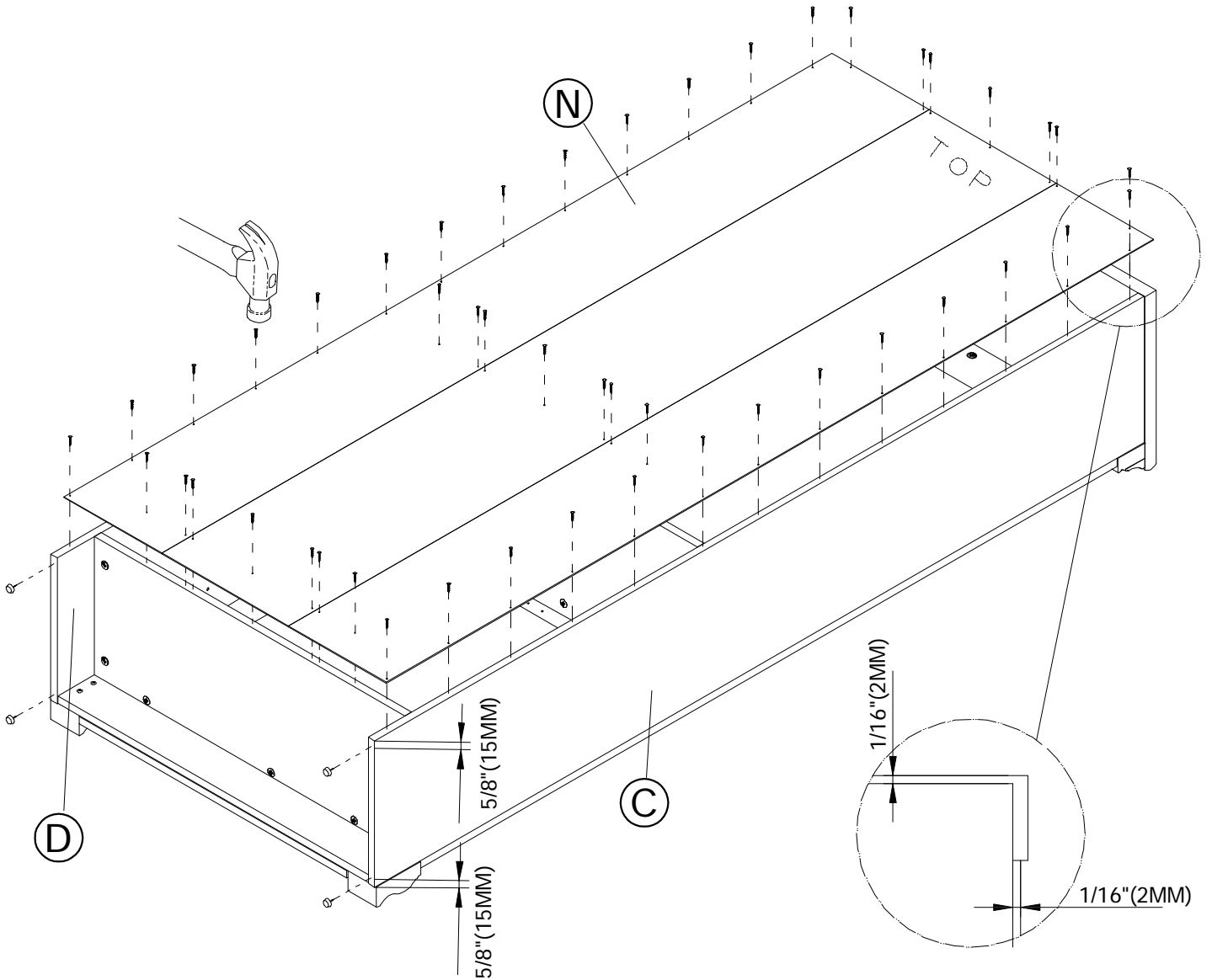

H67866

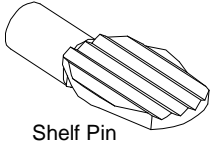

[ 12 ]

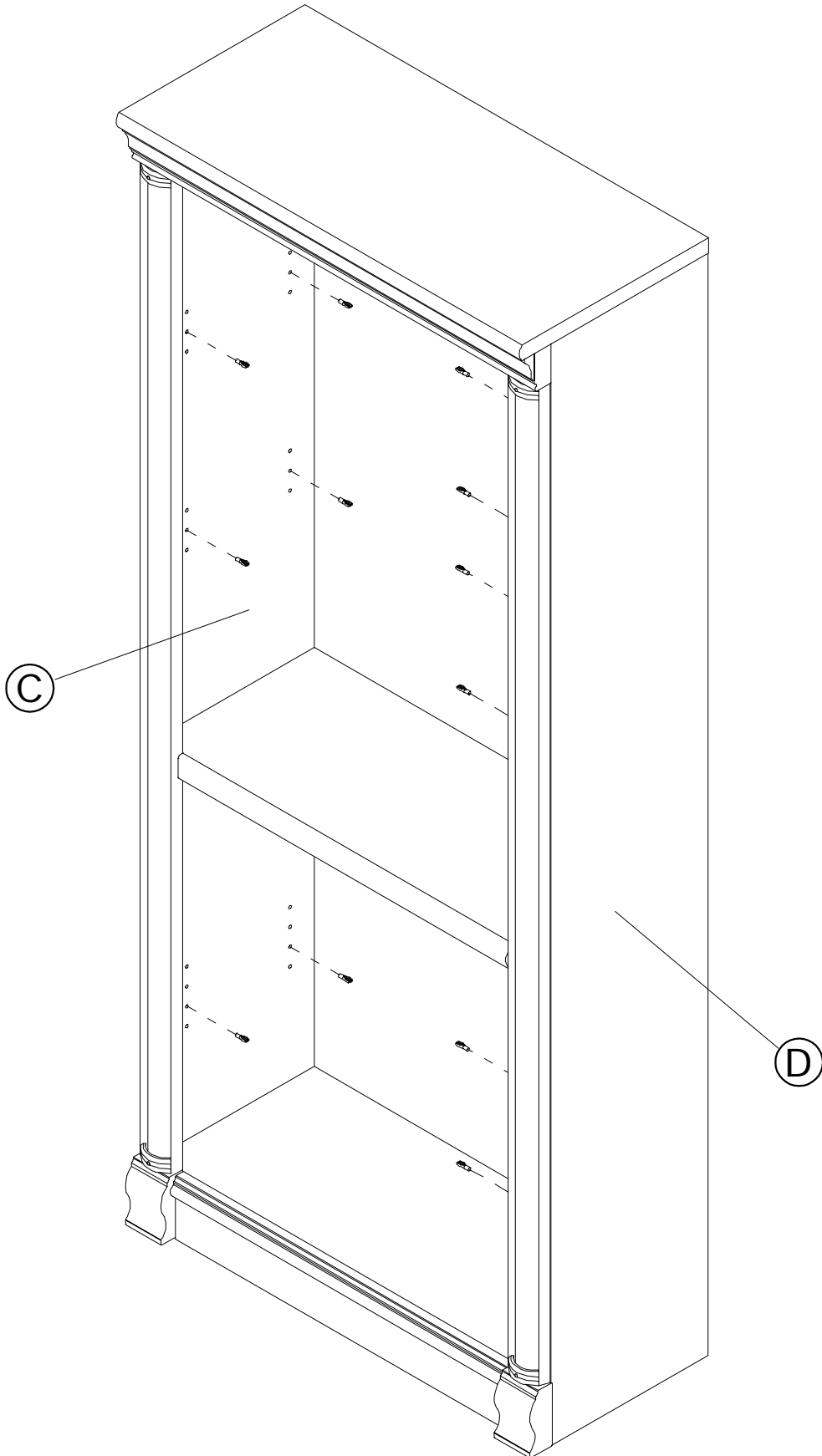



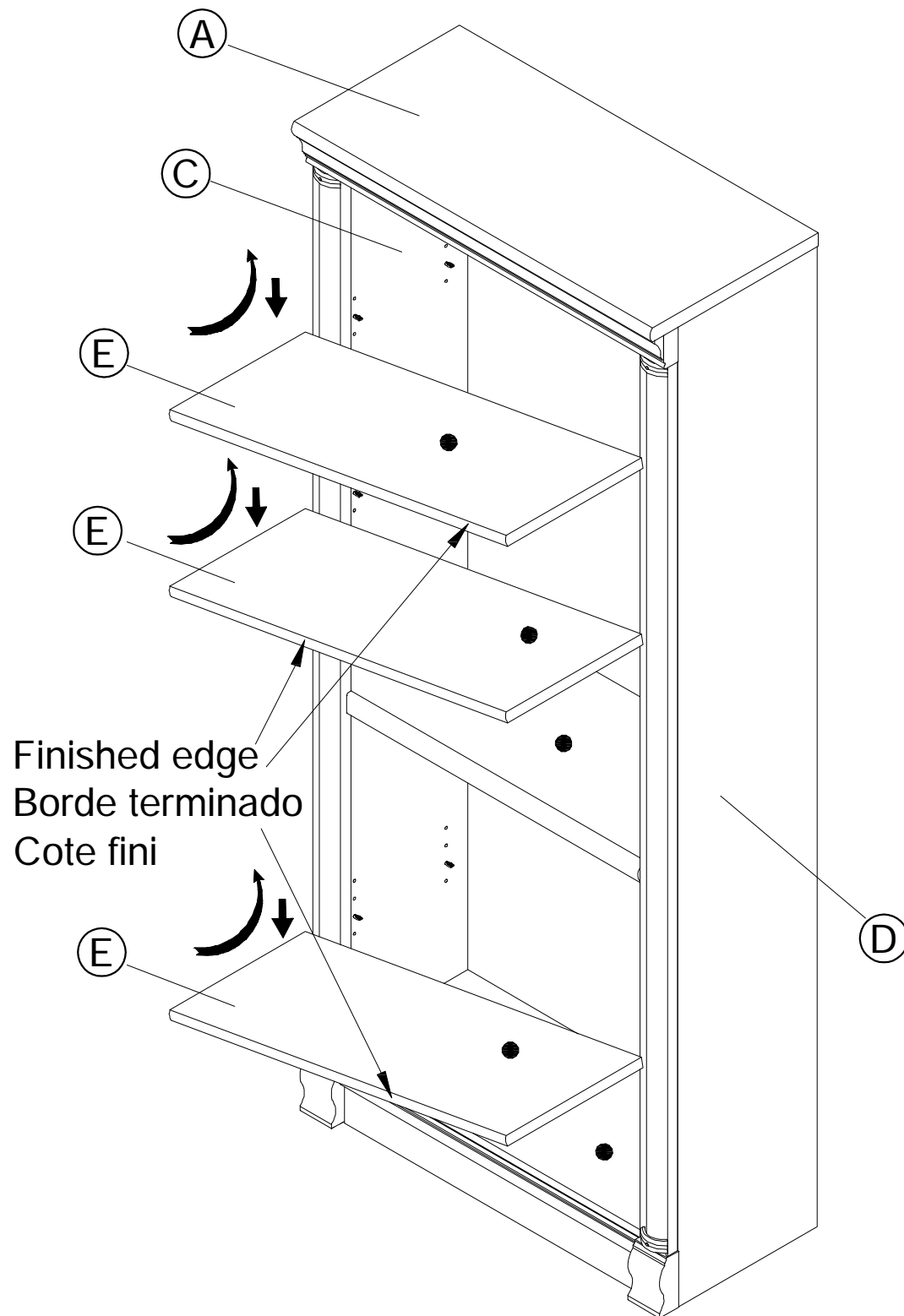

Secure unit to the wall with a tip-over restraint.

Unidad de seguro a la pared con un sistema de retención de un vuelco.

Fixer l'unité au mur avec un dispositif de retenue renversement.

1. Place unit in desired location.
2. Locate wall stud nearest unit center. **FIG A**
3. On wall, mark center of stud location 1" below top of unit. **FIG A**
4. If a wall stud cannot be located mark hollow wall at unit center. **FIG A**
5. On back of unit, mark corresponding location 5/16" below top of unit. **FIG B**

1. Coloque la unidad en el lugar deseado.
2. Localice pie derecho de pared centro de unidad más próxima.
3. En la pared del, marque el centro de la ubicación del montante 1 "abajo la parte superior de la unidad.
4. Si un poste de la pared no se puede localizar marcar pared hueca en el centro de la unidad.
5. En el dorso de la unidad, marque la ubicación 5/16" correspondiente abajo la parte superior de la unidad.

1. Placez l'unité à l'endroit désiré.
2. Localiser centre d'unité la plus proche de la paroi Stud.
3. Sur le mur, centre de emplacement du montant 1 "ci-dessous dessus de l'appareil de la marque.
4. Si un montant de mur ne peut pas être situé marquer mur creux au centre de l'unité.
5. Le dos de l'appareil, marquer l'emplacement 5/16" correspondant ci-dessous dessus de l'appareil.

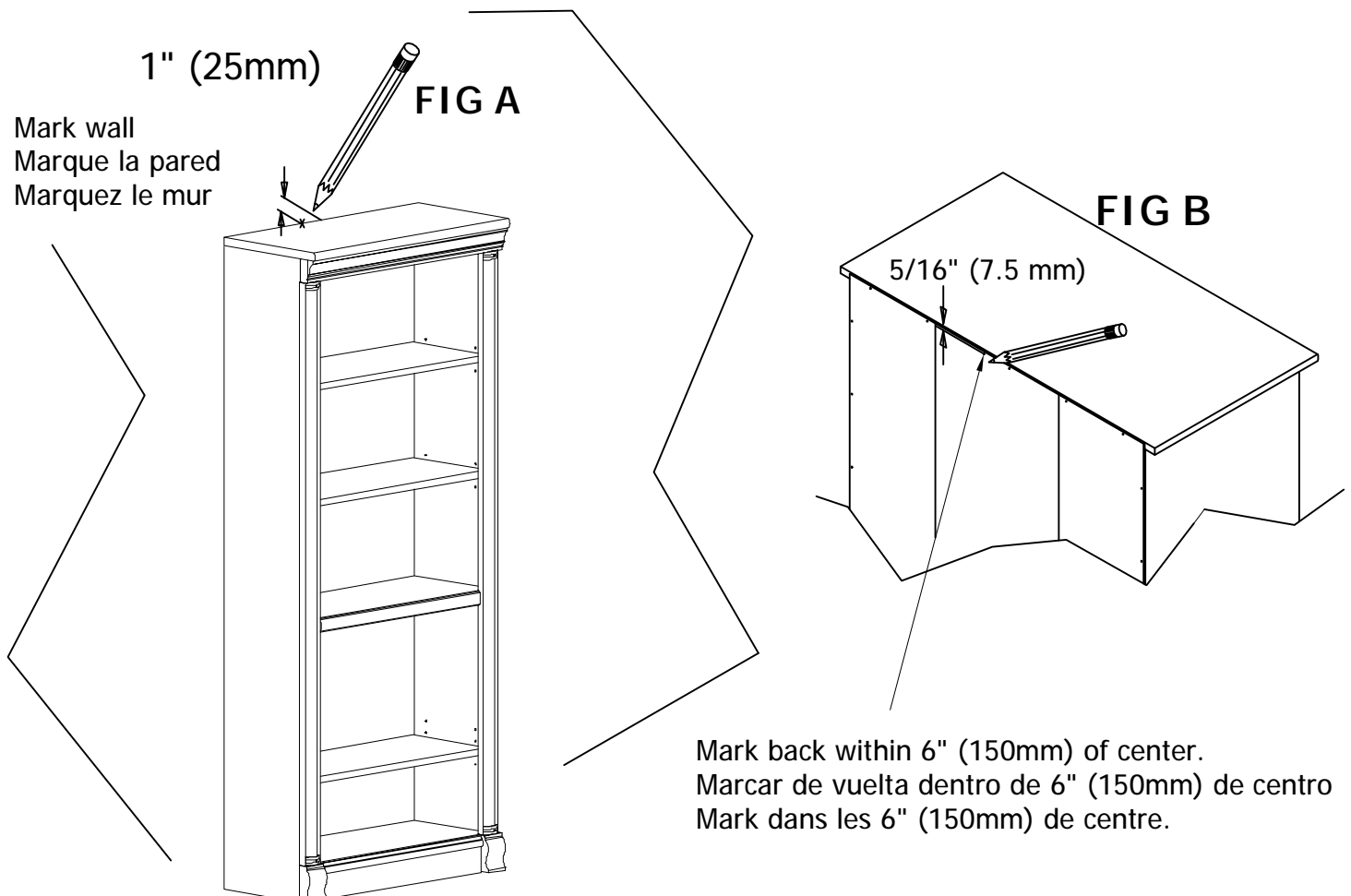

# WALL STUD ATTACHMENT

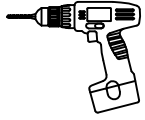

Drill 1/8" hole 2" deep at mark on wall.

Taladro 1/8 "agujero 2" de profundidad en la marca en la pared.

Percer 1/8 "trou de 2" de profondeur à la marque sur le mur.

H181434

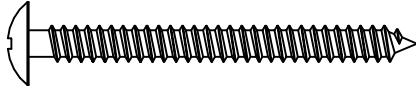

[ 1 ]

#10x2"

H181412

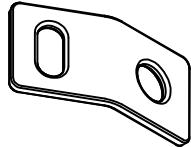

[ 1 ]

Connecting Plate

Drywall  
Paneles de yeso  
cloisons sèches

Wood stud  
Montante de madera  
Stud bois

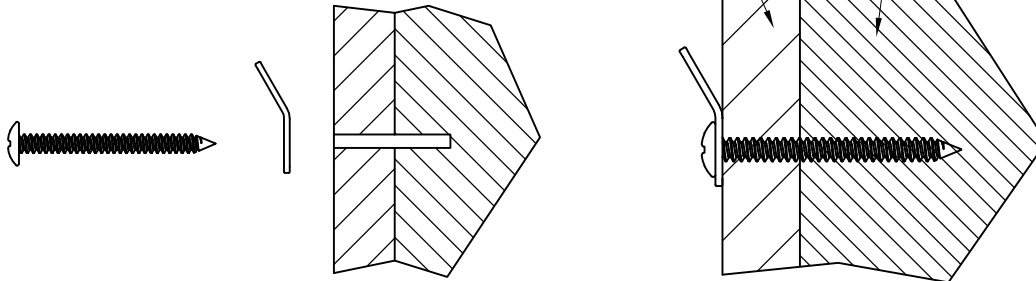

# HOLLOW WALL ATTACHMENT

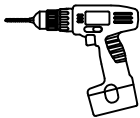

Drill 1/2" hole 1" deep at mark on wall.

Taladro 1/2 "agujero 1" de profundidad en la marca en la pared.

Percer 1/2 "trou de 1" de profondeur à la marque sur le mur.

H181419

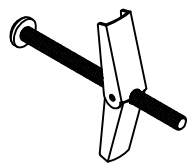

[ 1 ]

Toggle Bolt

H181412

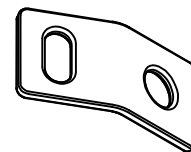

[ 1 ]

Connecting Plate

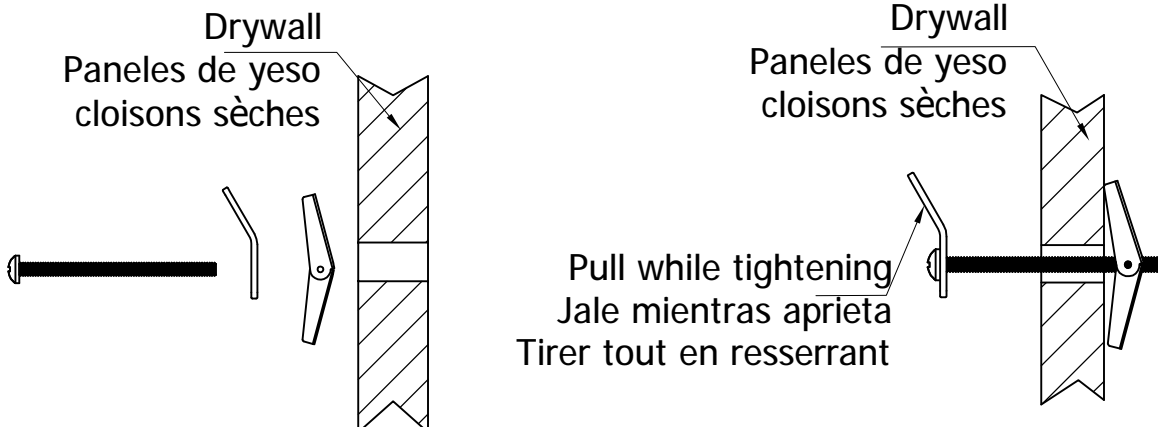

Drywall  
Paneles de yeso  
cloisons sèches

Drywall  
Paneles de yeso  
cloisons sèches

Pull while tightening  
Jale mientras aprieta  
Tirer tout en resserrant

H145191



#8 x 3/4"

[ 1 ]

H181412

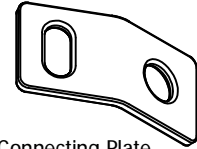

Connecting Plate

[ 1 ]

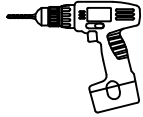

Drill 1/8" hole 1/2" deep at mark on unit.

Taladro 1/8 "agujero de 1/2" de profundidad en la marca de la unidad.

Perçer 1/8 "trou 1/2" de profondeur à la marque sur l'unité.

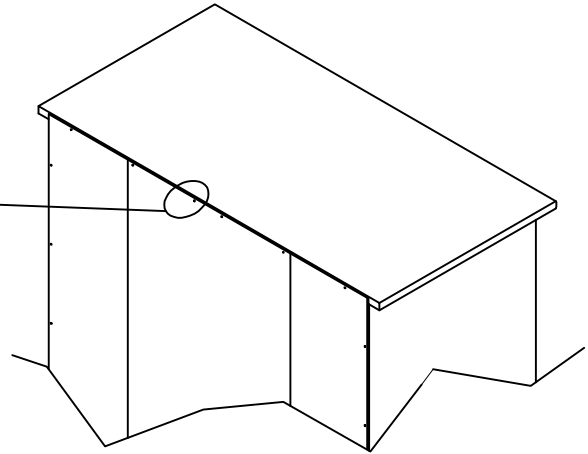
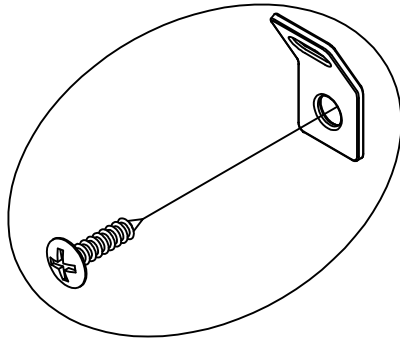

H181411

Nylon Cable Tie

[ 1 ]

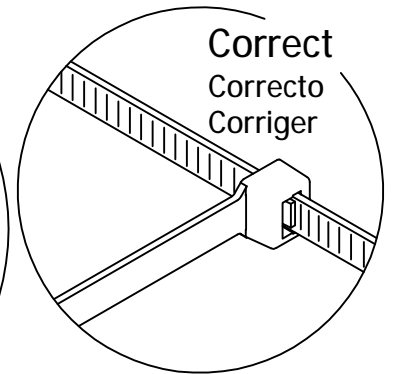
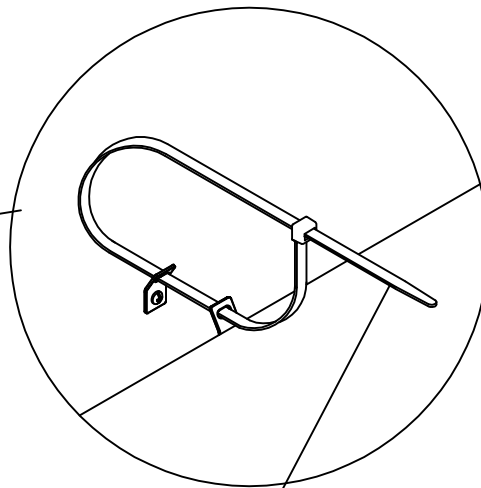
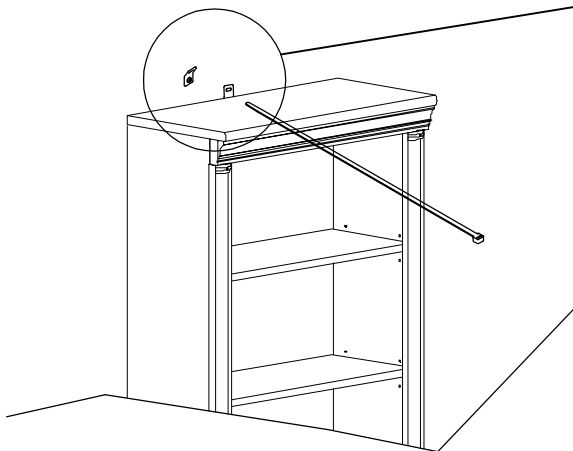
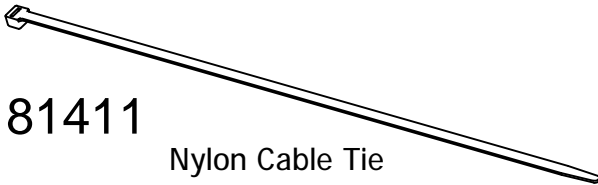

Correct  
Correcto  
Corriger

Pull to verify lock

Tire para verificar cerradura

Tirez pour vérifier serrure

Use replacement cable tie with minimum breaking strength of 120lbs.

Utilice reemplazo empaque Cable con resistencia a la rotura mínima de 120 libras.

Utilisez remplacement Attache de câble avec une force de rupture minimale de 120 lbs.

THIS PAGE INTENTIONALLY LEFT BLANK

THIS PAGE INTENTIONALLY LEFT BLANK

THIS PAGE INTENTIONALLY LEFT BLANK

# WARRANTY INFORMATION/INFORMATIONS POUR LA GARANTIE/INFORMACIÓN DE GARANTÍA

## BUSH FURNITURE'S WRITTEN WARRANTY TO YOU

In order to provide you with timely assistance, please thoroughly inspect your furniture for missing or defective parts immediately after opening the carton. To receive replacement or missing parts under this warranty, call our Consumer Service Department TOLL-FREE at 1-800-950-4782. Please have the Model, Part, and Lot Numbers found in the instruction manual available for your reference. You will also need your sales receipt or other proof of purchase. Replacement part(s) will be shipped to you at no charge with Bush Industries assuming all shipping and handling charges.

This Bush Furniture product is warranted to the original purchaser at the time of purchase and for a period of six years thereafter.

We warrant to you, the original purchaser, that our furniture and all its parts and components are free of defects in material or workmanship. "Defects," as used in this warranty, is defined as any imperfection which impairs the use of the furniture product.

Our warranty is expressly limited to the replacement of furniture parts and components. For six years after the date of purchase, Bush will replace any parts that are defective in material or workmanship.

This warranty applies under conditions of normal use. Our Bush Furniture products are not intended for outdoor use. This warranty does not cover: 1) defects caused by improper assembly or disassembly; 2) defects occurring after purchase due to product modification, intentional damage, accident, misuse, abuse, negligence or exposure to the elements; and 3) labor or assembly costs.

IMPLIED WARRANTIES, INCLUDING THE WARRANTY OF MERCHANTABILITY, SHALL NOT EXTEND BEYOND THE DURATION OF THE WRITTEN WARRANTY STATED ABOVE, AND IN NO EVENT SHALL BUSH BE LIABLE FOR INCIDENTAL OR CONSEQUENTIAL DAMAGES RESULTING FROM USE OF THE PRODUCT. Some states do not allow a limitation on how long an implied warranty lasts or the exclusion or limitation of incidental or consequential damages, so the above limitation and exclusion may not apply to you.

This warranty gives you specific legal rights. You may also have other rights that may vary from state to state.

## VOTRE GARANTIE BUSH FURNITURE

Afin de vous assister rapidement, veuillez inspecter votre mobilier en détail immédiatement après l'ouverture du carton en cas de pièces manquantes ou défectueuses. Pour recevoir une pièce de rechange ou manquante couverte par cette garantie, appelez notre département de service clientèle GRATUITEMENT au 1-800-950-4782. Veuillez tenir à disposition les numéros de modèle, de pièce et de lot qui se trouvent dans le manuel d'instruction pour votre référence. Vous aurez également besoin de votre reçu ou d'une autre preuve d'achat. La (les) pièce(s) de rechange vous sera (seront) envoyée(s) sans frais, Bush Industries se chargeant de tous les frais d'expédition.

Tout le produit Bush Furniture est garanti à l'acheteur original à partir de la date d'achat pour une période d'e six ans.

Nous vous garantissons, à vous l'acheteur original, que notre mobilier et toutes ses pièces et composants sont sans défaut de matériau ou de fabrication. Le terme "défauts" utilisé dans cette garantie, est défini comme étant toutes les imperfections qui compromettent l'utilisation du meuble.

Notre garantie est expressément limitée au remplacement des pièces et des composants du mobilier. Pendant six ans après la date d'achat, Bush remplacera toute pièce défectueuse dans le matériau ou sa fabrication.

Cette garantie d'applique sous des conditions d'utilisation normale. Nos produits ne sont pas destinés à être utilisés en plein air. Cette garantie ne couvre pas: 1) les défauts causés par un mauvais assemblage ou démontage, 2) les défauts ayant lieu après l'achat et dus à la modification du produit, des dommages intentionnels, des accidents, une mauvaise utilisation, un mauvais traitement, la négligence ou l'exposition aux éléments, et 3) les frais de main d'œuvre ou d'assemblage.

LES GARANTIES TACITES, Y COMPRIS LA GARANTIE DE QUALITE MARCHANDE, NE S'ETENDRONT PAS AU-DELA DE LA DUREE ECRITE CITEE CI-DESSUS, ET BUSH NE SERA EN AUCUN CAS RESPONSABLE DES DOMMAGES ACCESSOIRES OU INDIRECTS RESULTANT DE L'UTILISATION DU PRODUIT. Certains états ne permettent pas d'appliquer une limite à la durée de la garantie tacite, ni une exclusion ou limitation des dommages accessoires ou indirects; dans ce cas les limitations ou exclusion ci-dessus peuvent ne pas s'appliquer à vous.

Cette garantie vous donne des droits légaux spécifiques. Il se peut que vous ayez également d'autres droits qui peuvent varier d'un état à l'autre.

## GARANTIA ESCRITA DE BUSH FURNITURE PARA USTED

Para brindarle asistencia oportuna, por favor, verifique detalladamente que a su mueble no le falte o tenga piezas defectuosas inmediatamente después de abrir la caja. Para recibir un reemplazo o la parte faltante bajo esta garantía, llame a nuestro Departamento de Servicio al Consumidor GRATIS al 1-800-950-4782. Sírvase traer los números de modelo, parte y lote que se encuentran en el manual de instrucciones disponible para su referencia. Además, necesitará el recibo de su compra u otra prueba de compra. La(s) pieza(s) de reemplazo le será(n) enviada(s) sin recargo por Bush Industries asumiendo los gastos de envío y manipuleo.

Todo mueble de Bush Furniture es garantizado al comprador original al momento de la compra y por un periodo de seis años en adelante.

Le garantizamos a usted, el comprador original, que nuestros muebles sus partes y componentes están libres de defectos en materiales o trabajo. "Defectos", según se usa en esta garantía, se define como una imperfección que perjudica el uso del producto mobiliario.

Nuestra garantía se limita expresamente al reemplazo de partes y componentes mobiliarios. Durante seis años después de la fecha de compra, Bush reemplazará cualquier parte defectuosa en material o trabajo.

Esta garantía se aplica bajo condiciones de uso normal. Nuestros productos de Bush Furniture no son para uso en exteriores. Esta garantía no cubre: 1) defectos causados por un ensamblaje o desensamblaje inadecuado; 2) defectos que ocurran después de la compra debido a modificación del producto, daño intencional, accidente, mal uso, abuso, negligencia o exposición a los elementos; y 3) costos de trabajo o ensamblaje.

LAS GARANTÍAS IMPLICADAS, INCLUYENDO LA GARANTÍA DE COMERCIABILIDAD, NO SE EXTENDERÁN MÁS ALLÁ DE LA DURACIÓN DE LA GARANTÍA ESCRITA MENCIONADA, Y EN NINGÚN CASO BUSH SERÁ RESPONSABLE POR DAÑOS INCIDENTALES O CONSIGUIENTES COMO RESULTADO DEL USO DEL PRODUCTO. Algunos estados no permiten una limitación sobre el tiempo de duración de la garantía implicada o la exclusión o limitación de daños incidentales o consiguientes, de manera que la limitación y exclusión mencionadas pueden no aplicarse para usted.

Esta garantía le otorga derechos legales específicos. Puede también tener otros derechos que pueden variar según los estados.

**6-Year**  
Manufacturer's  
Warranty

**REGISTER YOUR PRODUCT ONLINE AT**  
<http://www.bushfurniture.com/ProductRegistration.aspx>