

Model DK-2 Drafting Kit Assembly

Parts Listing

A
Circular Foot Rest
1 Unit

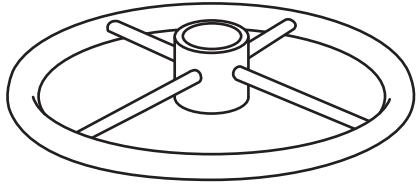

B
Tension Knob
1 Unit

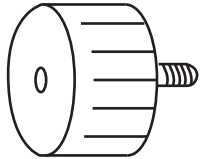

C
9" Extension Tube
1 Unit



D
12" Extension Tube
1 Unit

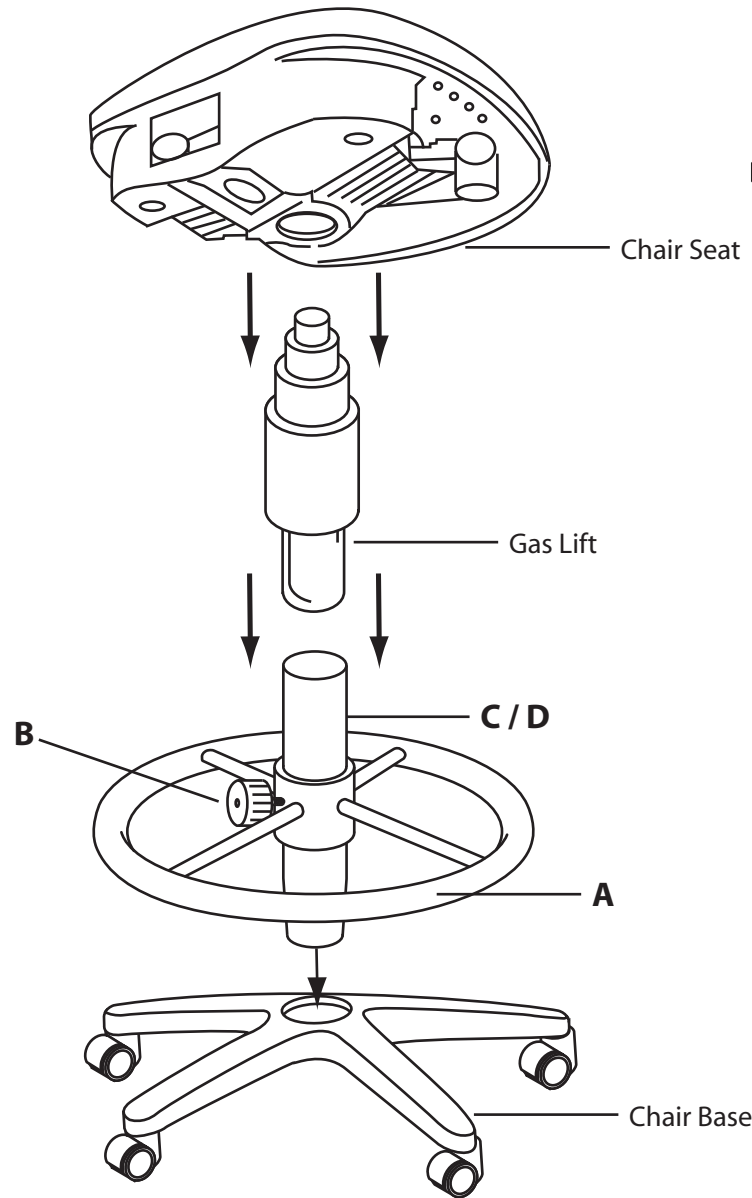

Assembly Instructions



*Please read all instructions before assembly.
Prior to assembly, select only one Extension Tube
for desired Height*

*9" Extension Tube will change seat height from 24"-28"
12" Extension Tube will change seat height from 27-31"*

Step 1: Slide the Circular Foot Rest (A) over the smaller tapered end of your chosen Extension Tube (C / D).

Step 2: Screw in Tension Knob (B) and tighten to lock Foot Rest (A).

Step 3: Place the tapered end of Extension Tube (C / D) into your Chair Base.

Step 4: Insert bottom of Gas Lift Cylinder into the top end of the Extension Tube (C / D).

Step 5: Place the Chair Seat onto the Gas Lift by inserting top of Gas Lift into the hole in the Seat Mechanism.

Step 6: Press down firmly to secure the chair.

Note: Save the left over extension tube for future use.

ofm
Furniture For The Real Office™

161 Tradition Trail Holly Springs, NC, 27540
800-520-7471 (voice) 919-362-4765 (fax)
919-303-6389 (voice) www.ofminc.com
support@ofminc.com