

Models: 414 / 414-VAM Contract Upholstered Arm Chair

Parts Listing

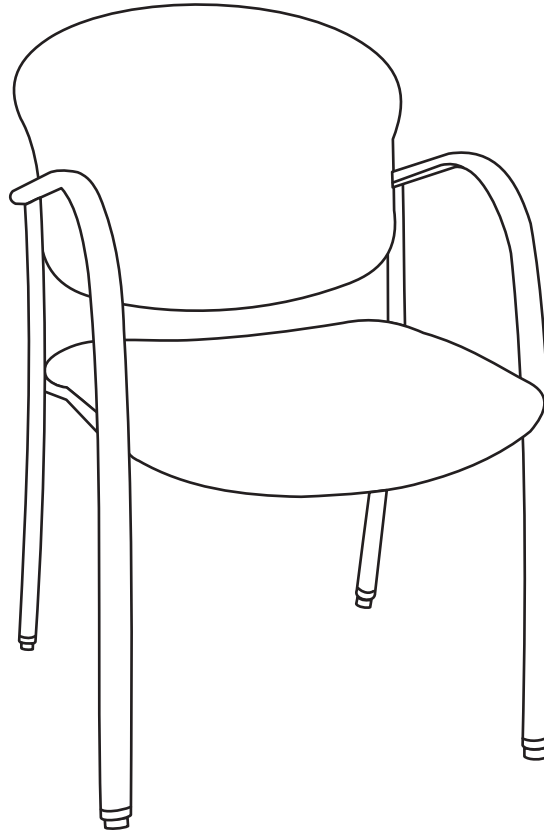

Assembly Instructions

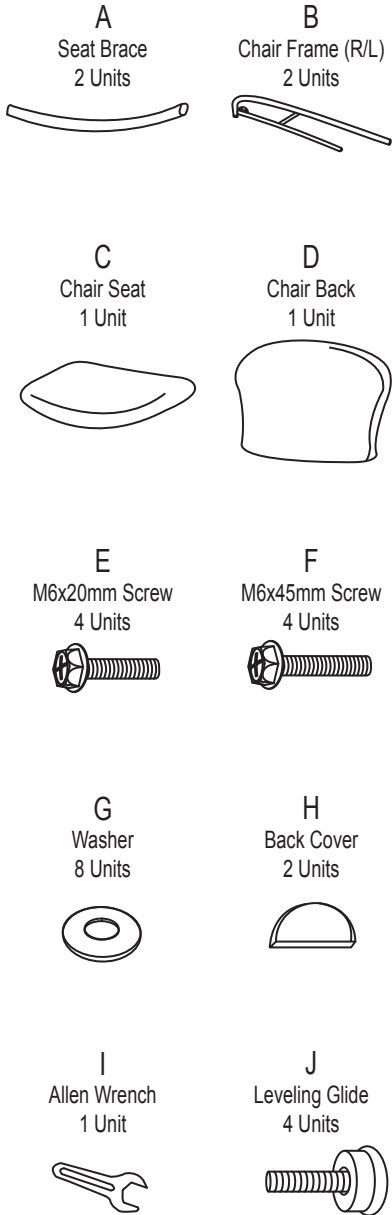

Tools Needed: Phillips Head Screwdriver
Please read all instructions before assembly.

- Step 1:** Insert Seat Braces (A) into the Chair Frame (B) holes.
- Step 2:** Attach Chair Seat (C) to frame by inserting M6x45mm Screws (F) and Washers (G) through Seat Brace (A) and into the pre-drilled holes in the Chair Seat (C). Tighten screws with Allen Wrench (I), provided, or use screwdriver.
- Step 3:** Attach Chair Back (D) to frame by inserting M6x20mm Screws (E) and Washers (G) through metal tabs and into the pre-drilled holes in the Chair Back (D). Tighten screws with Allen Wrench (I), provided, or use screwdriver.
- Step 4:** Cover Screws (E) and metal tabs with Back Covers (H). Press firmly to secure.
- Step 5:** Insert the adjustable Leveling Glides (J) into the bottom of the chair legs, if desired.

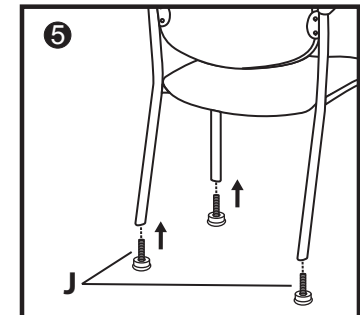
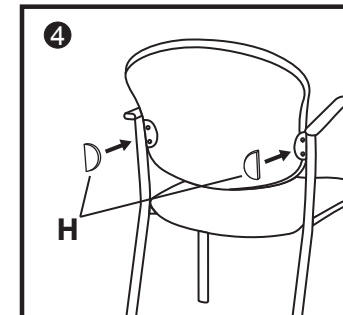
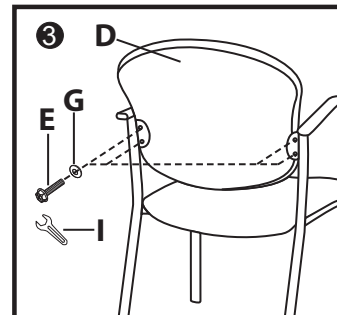
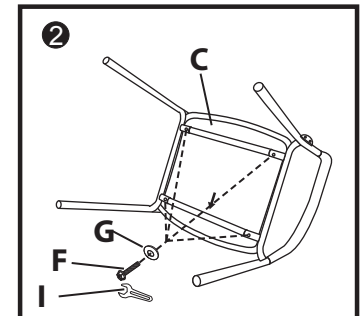
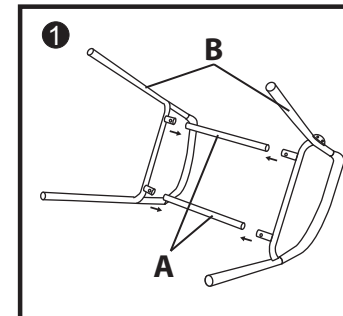

WEIGHT CAPACITY: 250 lbs.

Assembly Notes:

During assembly, hand tighten screws only. When all screws are in place, you may then tighten all screws completely.

CAUTION:

1. Do not use this chair as a step ladder.
2. Check for loose screws and tighten them every 6 months.

ofm
Furniture For The Real Office™

161 Tradition Trail, Holly Springs, NC, 27540
800-520-7471 (voice) 919-362-4765 (fax)
919-303-6389 (voice) www.ofminc.com
support@ofminc.com