

SEATING PLAN

SCALE: 3/8"=1'-0"

NET SEATS = 30

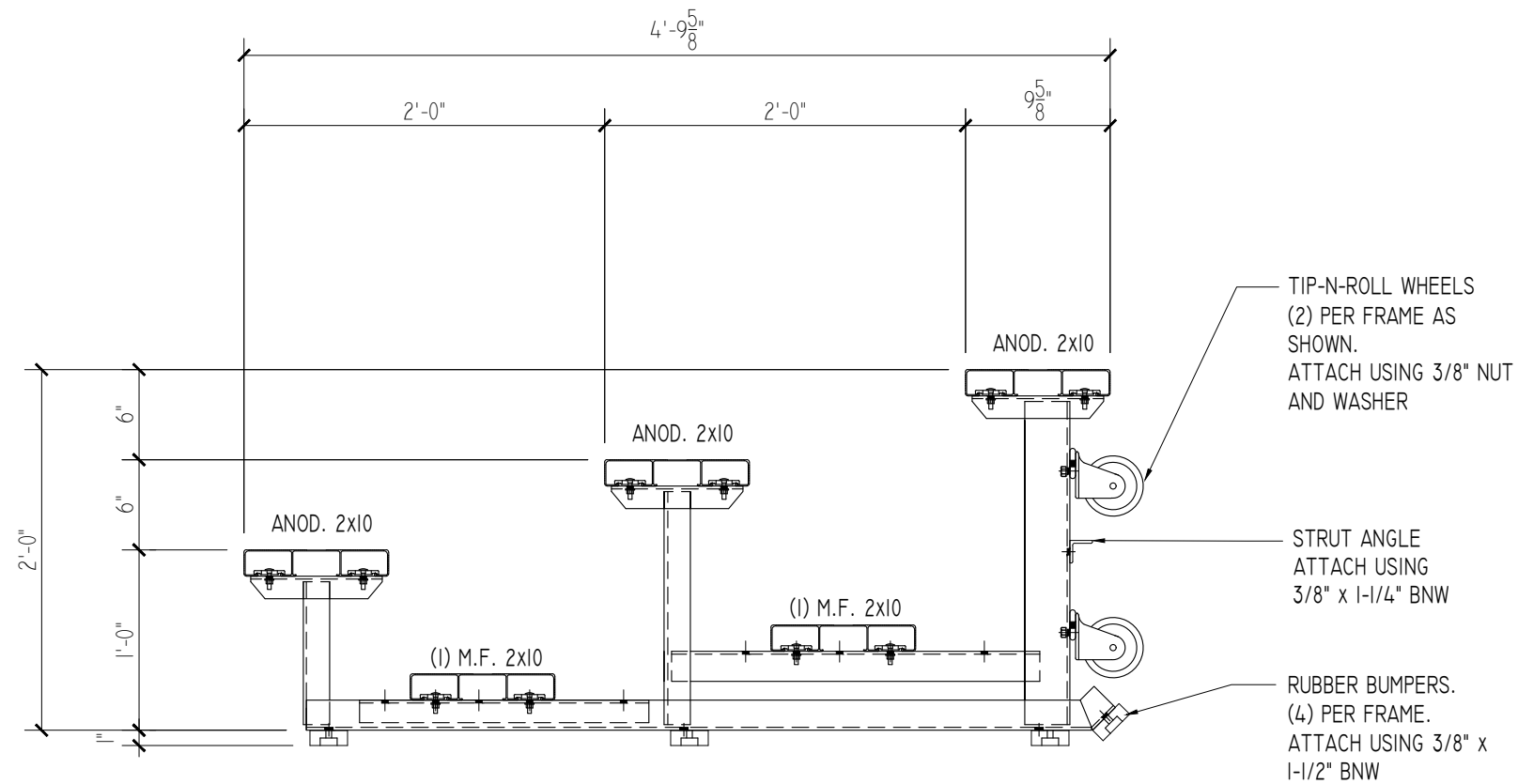

TYPICAL SECTION THRU BLEACHER

SCALE: 1"=1'-0"

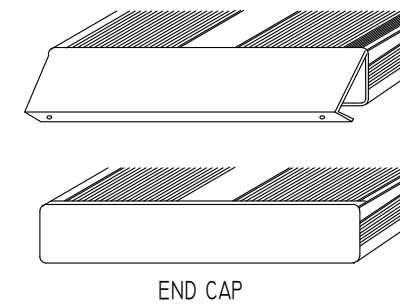

END CAP

1. LOCATE THE CHANNEL END CAP AS SHOWN, WITH THE WIDER FLANGE ON BOTTOM.
2. TAP THE CHANNEL INTO PLACE WITH A RUBBER Mallet OR SOFT WOOD.
3. DRILL (2) No.8 x 3/4" TEK SCREWS THRU END CAP AND BOTTOM FLANGE OF PLANK
4. ENDCAPS WITH STICKERS ARE TO GO AT ENDS OF SEAT PLANKS, PLAIN ENDCAPS GO ON ALL OTHER BOARDS.

ENDCAP INSTALLATION DETAIL

SCALE: 3" = 1'-0"

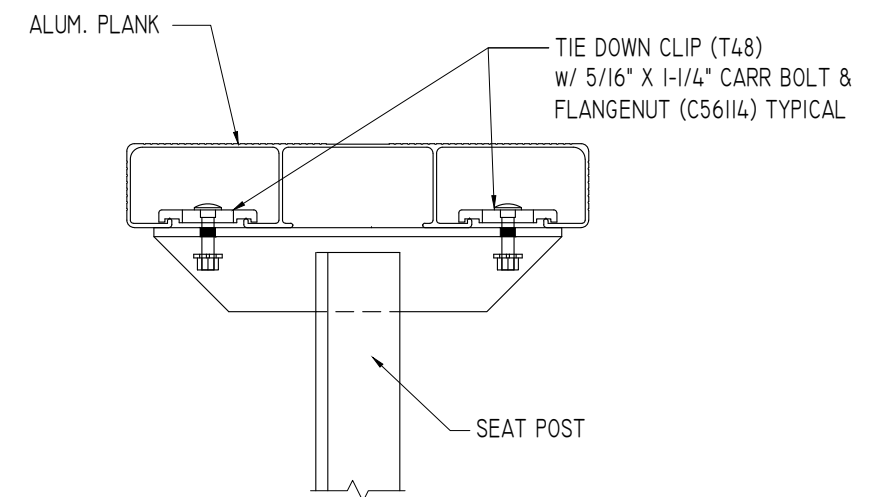

SEAT PLANK INSTALLATION

SCALE: 3" = 1'-0"