

SEATING PLAN

SCALE: 3/8"=1'-0"

NET SEATS = 28

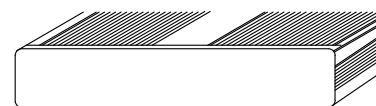
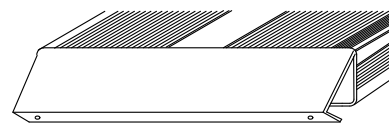

END CAP

1. LOCATE THE CHANNEL END CAP AS SHOWN, WITH THE WIDER FLANGE ON BOTTOM.
2. TAP THE CHANNEL INTO PLACE WITH A RUBBER Mallet OR SOFT WOOD.
3. DRILL (2) No.8 x 3/4" TEK SCREWS THRU END CAP AND BOTTOM FLANGE OF PLANK
4. ENDCAPS WITH STICKERS ARE TO GO AT ENDS OF SEAT PLANKS, PLAIN ENDCAPS GO ON ALL OTHER BOARDS.

ENDCAP INSTALLATION DETAIL

SCALE: 3" = 1'-0"

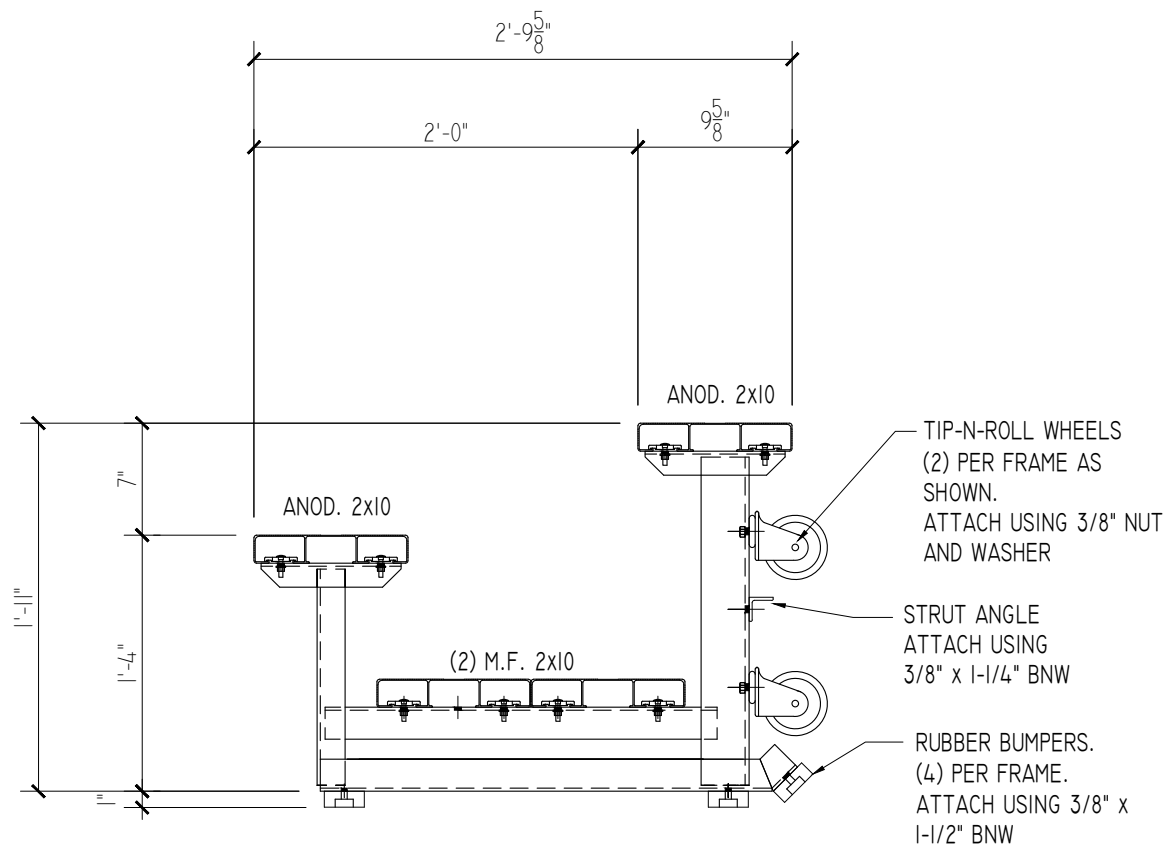

TYPICAL SECTION THRU BLEACHER

SCALE: 1"=1'-0"

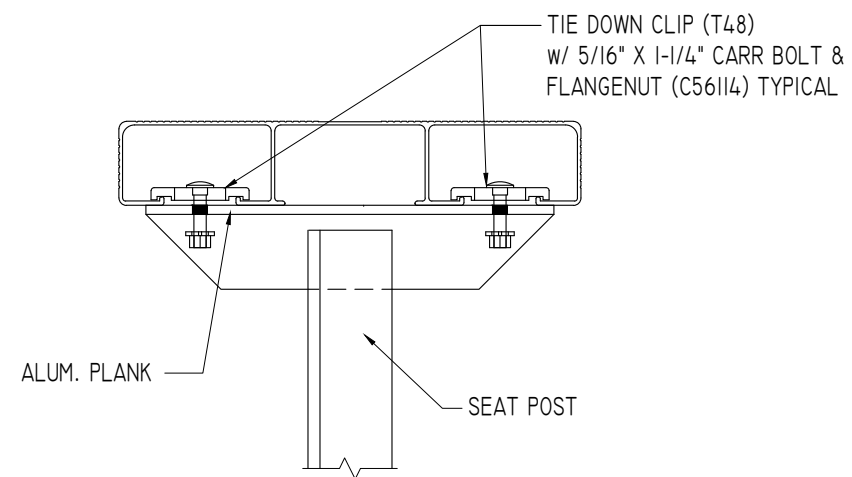

SEAT PLANK INSTALLATION

SCALE: 3" = 1'-0"

2810 Sydney Road
Plant City, Florida 33566
Phone: 813-305-1415
Fax: 813-305-1419
www.gtgrandstands.com



SEATING PLAN
2 ROW BLEACHER
TIP -N- ROLL

NR-022IAD-TR AND
NR-022IGD-TR

DRAWN BY
CHECKED BY
DATE
MAR 2010
SCALE
NOTED
JOB NO.
NR-022IAD-TR
NR-022IGD-TR
DWG NO.