

ASSEMBLY INSTRUCTIONS
INSTRUCCIONES DE MONTAGE
INSTRUCCIONES DE ENSAMBLAJE

2133BL

Knob-Adjust Platform Keyboard

Molette-Ajuster Keyboard Platform

Perilla-Ajuste Keyboard Platform

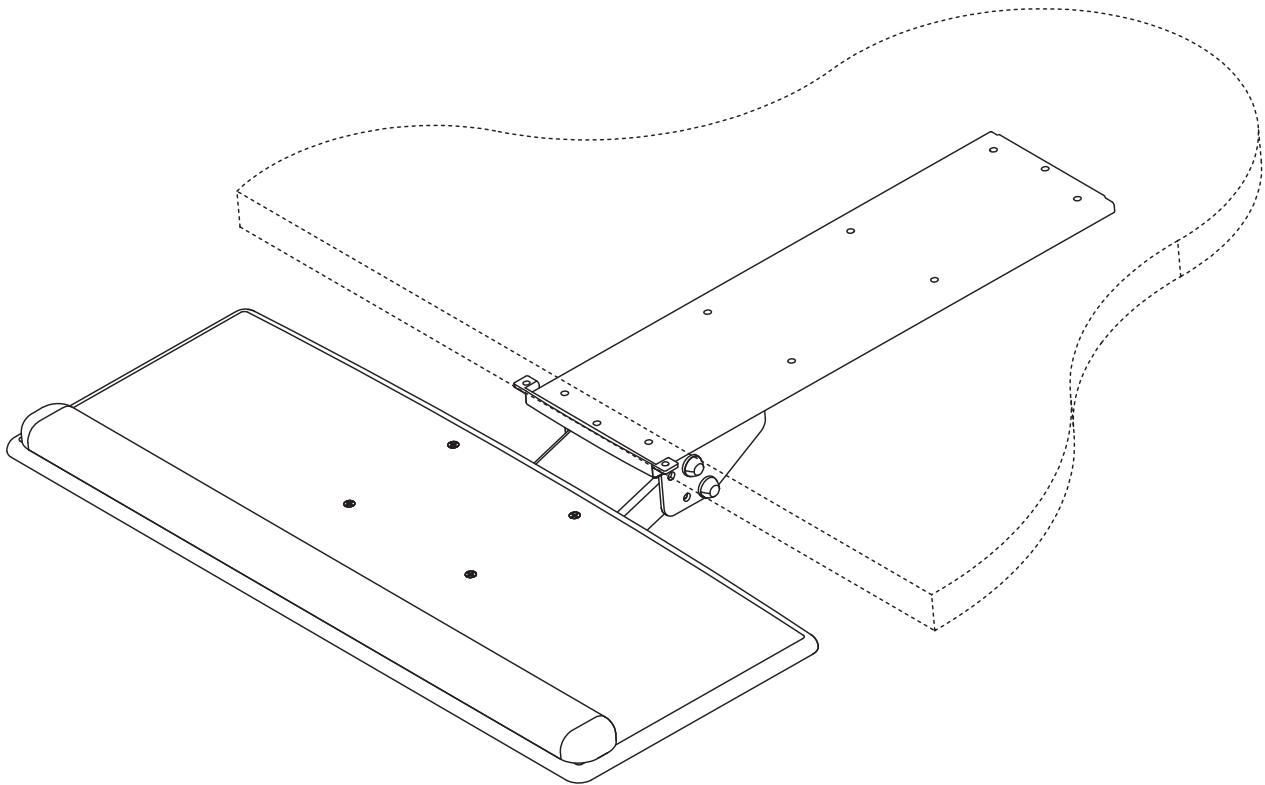

PRODUCT WARRANTY REGISTRATION is available online at: www.safcoproducts.com

• L'INSCRIPTION POUR LA GARANTIE DU PRODUIT est disponible sur l'Internet : www.safcoproducts.com

• EI REGISTRO PARA LA GARANTÍA DEL PRODUCTO está disponible en la Internet: www.safcoproducts.com

For questions or concerns, please call **1-800-664-0042**
available Monday-Friday 7:00 AM to 6:00 PM (Central Time) (English-speaking operators)

Si vous avez des questions pour poser ou les préoccupations pour exprimer, connecter **au 1-800-664-0042** de 7H00 à 18H00 (Heure centrale) (Opérateurs de langue anglaise)

Si usted tiene preguntas o preocupaciones, por favor llame **1-800-664-0042** de 7:00 AM a 6:00 PM (Hora Central) (Operadores que hablan inglés)







TOOLS REQUIRED: Adjustable Wrench, Phillips Screwdriver, Pencil, Drill with 1/8"bit, Masking Tape
OUTILS REQUIS: *Clef Allen (incluse), Clef ajustable, Tournevis à pointe cruciforme Crayon, Perceuse avec mèche de 3 mm , Ruban de papier adhésif*

HERRAMIENTAS REQUERIDAS: Llave Allen (incluida), Llave ajustable, Destornillador Phillips®, Lápiz, Taladro con broca de 1/8 pulg., Cinta de ADHESIVA PINTOR

Parts List / Liste des Pièces / Lista de Piezas

CODE	DESCRIPTION	QTY	PART NO.
(A)	Mechanism/ Mécanisme/ Mecanismo	1	2135-51BL
(B)	Keyboard Tray/ Plateau de clavie/ Bandeja de teclado	1	2133-01BL
(C)	Track/ Rail// Soporte	1	2135-54BL
(D)	Wristrest/ Repose-poigne/ Descansabrazos	1	2133-02BL

**HARDWARE PACK / PAQUET MATÉRIEL / PAQUETE MATERIAL
2133-19NC**

 E Sharp Screw <i>Vis pointue</i> Tornillo agudo Qty. / Qte. / Cant.: 12 #2133-01NC	 F Small Nut <i>Petit écrou</i> Tuerca pequeña Qty. / Qte. / Cant.: 4 #2133-02NC	 G Small Flat Head Screw <i>Petit Vis à tête plate</i> Tornillo de cabeza llana pequeña Qty. / Qte. / Cant.: 4 #2133-03NC	 H Bumper <i>Pare-chocs</i> Parachoques Qty. / Qte. / Cant.: 1 #2133-04NC	 I Non-Skid Pad <i>Protection antidérapante</i> Cojín antideslizante Qty. / Qte. / Cant.: 4 #2133-05NC	 K Endcap <i>Embout</i> Tapa del extremo Qty. / Qte. / Cant.: 1 #2133-06NC	 L Cord Clip <i>Attache de câble</i> cable del clip Qty. / Qte. / Cant.: 1 #2133-09BL
---	--	---	---	---	--	---

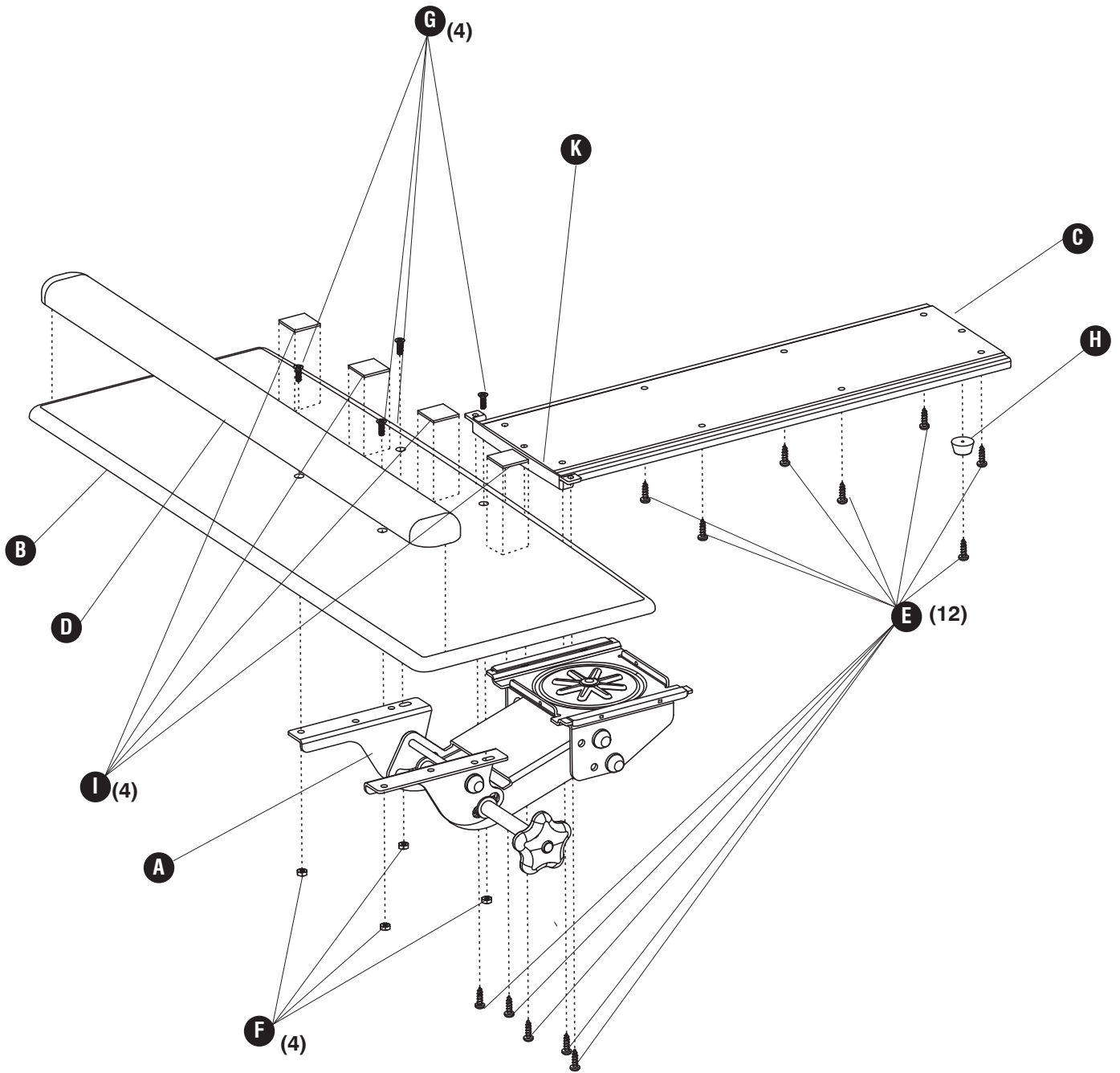

1

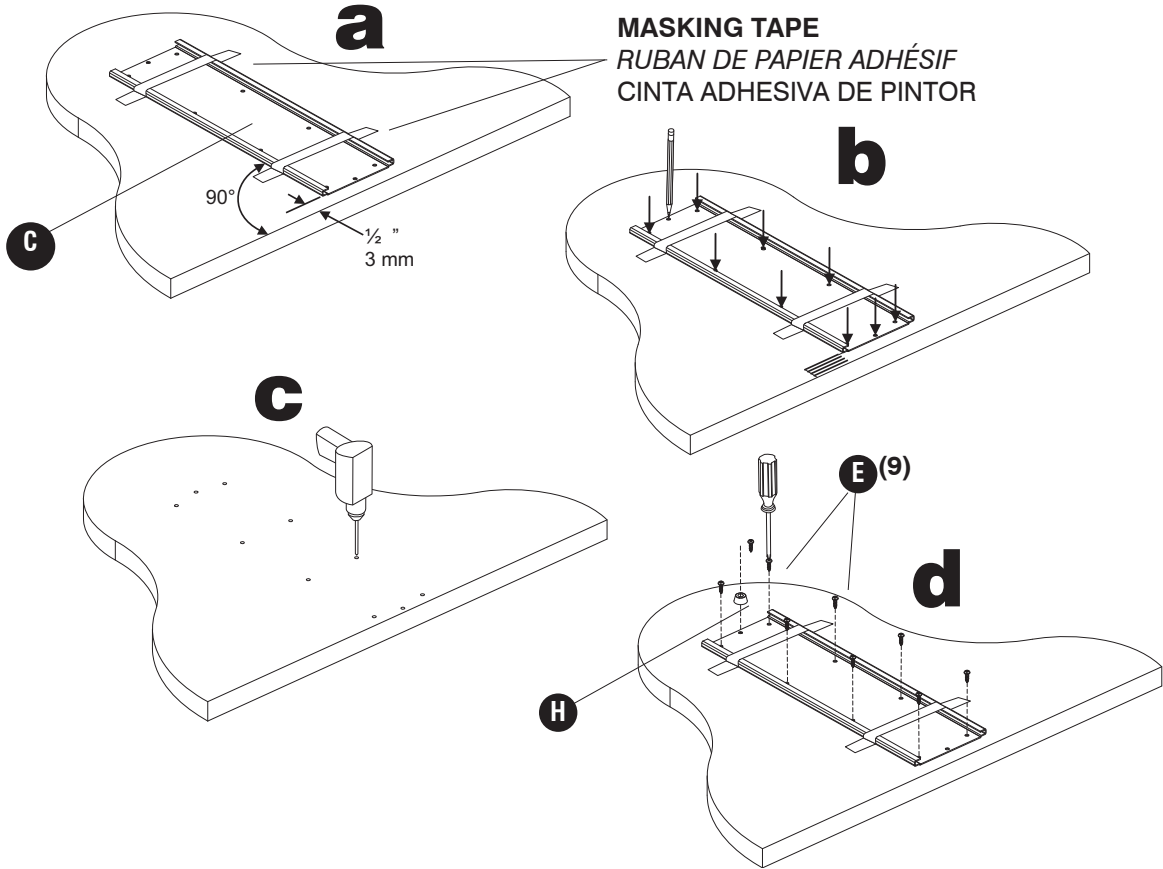
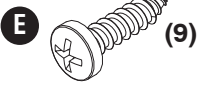

2

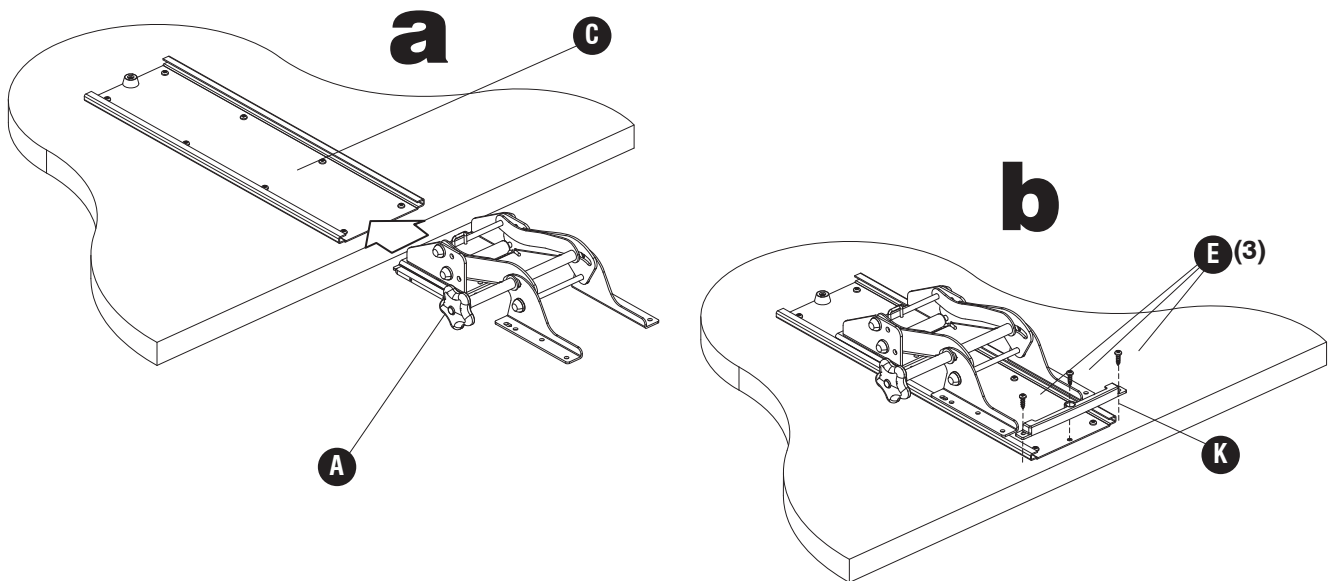
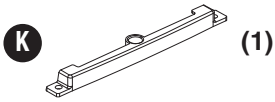
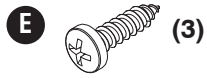

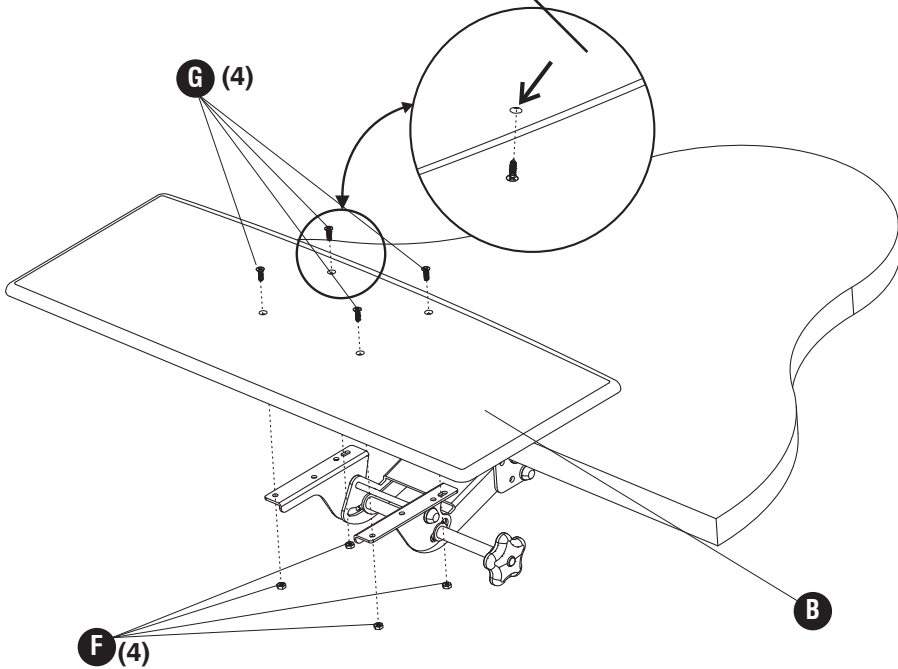
3**G****(4)****F****(4)****Bottom of Keyboard Tray***Bas de support de clavier**Parte inferior de la bandeja del teclado*

NOTE: The top holes are covered by the laminate material. Turn the Keyboard tray over and poke through the laminate material using one of the pointed screws provided.

NOTA: Les trous du haut sont couverts par le matériau stratifié. Tourner le plateau de clavier et pointer à travers le matériau stratifié à l'aide d'une des vis pointues fournies.

NOTA: Los agujeros superiores están cubiertas por el material laminado. Girar la bandeja de teclado y empujar a través del material laminado usando uno de los tornillos puntiagudos proporcionadas.

4

OPTIONAL
EN OPTION
OPCIONAL

I**(4)****L**

Place Non-Skid Pads (2155-05NC) in desired location
Placez Tapis antidérapants (2155-05NC) à l'endroit désiré
Coloque almohadillas antideslizantes (2155-05NC) en el lugar deseado

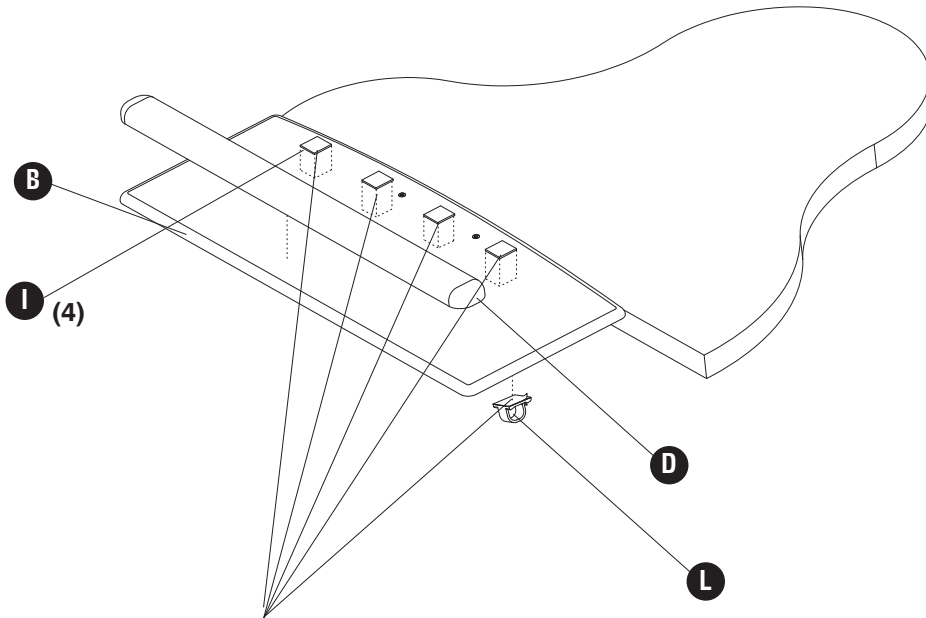

Remove paper to expose adhesive tape
retirez le papier d'exposer de ruban adhésif
retire el papel para exponer la cinta adhesiva