

## ASSEMBLY INSTRUCTIONS

Sort and count your parts!

For questions or concerns, please call  
**Safco Consumer Hot Line 1-800-664-0042**  
 available Monday-Friday 8:00 AM to 4:30 PM (Central Time)  
 (English-speaking operators)

PARTS LIST			
LETTER CODE	DESCRIPTION	QTY.	PART NO.
A	Track	1	2141-06
B	5/8" Tapping Screw	8	2136-23
C	Arm Mechanism	1	2196-05
D	Keyboard/Mouse Tray	1	2196-01
E	Machine Screw	4	2136-28
F	Endcap	1	2136-12
G	1/2" Thread-cutting Screw	2	2136-24
H	Keyboard Wrist Rest	1	2136-10
I	Mouse Wrist Rest	1	2137-11
J	Clear Mousing Surface	1	2137-14
K	Keyboard Pad	2	2136-13

**TOOLS REQUIRED: Phillips Screwdriver;  
 Drill with 1/8" Bit**

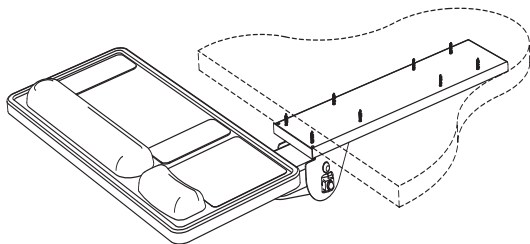

ASSEMBLED UNIT  
 MODEL 2196

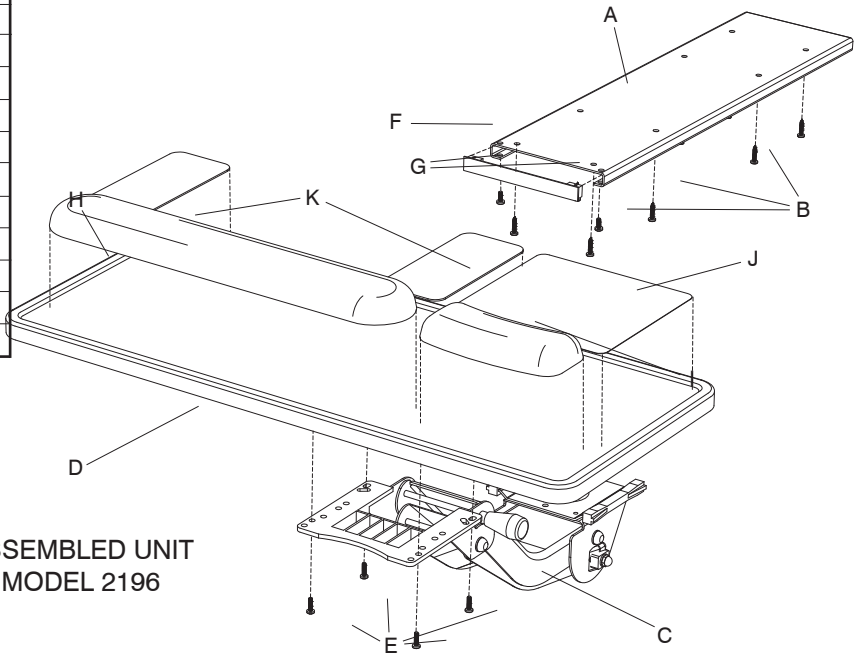

- 1** Mount the A Track to the underside of work surface as follows:
  - a) Make sure Track is mounted square to front edge of work surface.
  - b) Front edge of Track should be approximately 1/2" back from front of work surface.
  - c) Drill 1/8" pilot holes about 5/8" deep at each of the Track holes, taking care NOT to drill through to the other side of the work surface.
  - d) Install eight B 5/8" Tapping Screws along both sides of Track (four per side), and tighten enough to remove slight bow from Track.
- 2** Mount the C Arm Mechanism to the D Keyboard/Mouse Tray with four E Machine Screws into the threaded inserts on the underside of the Tray.
- 3** Loosen the lever on the Arm Mechanism, and lower the Mechanism to its "down" position. Retighten the lever.
- 4** Slide the Mechanism into the grooves of the Track until the Mechanism hits the backstop.
- 5** Fasten the F Endcap into place with two G 1/2" Thread-cutting Screws, going through the Track holes and into Endcap.
- 6** Temporarily set the H Keyboard Wrist Rest, your keyboard, the I Mouse Wrist Rest, and the J Clear Mousing Surface into place on the Keyboard Tray. Note that the Keyboard Wrist Rest has a slight slant, and the Mouse Wrist Rest has a slight curve; arrange these for your own comfort. Slide the two K Keyboard Pads under the ends of your keyboard until they properly support it; mark these positions and remove the keyboard. Peel off the protective paper backing on the backs of the two Wrist Rests and the Keyboard Pads and press them into place.
- 7** If desired, remove the protective paper from the adhesive spots on the J Clear Mousing Surface; mount it onto the Keyboard Tray. Slide your favorite photo under it.
- 8** Adjust the Mechanism as follows:
  - a) Lift the Keyboard Tray slightly to push in or pull out.
  - b) Lift and press down or pull up to adjust the height; release to lock in place.
  - c) Loosen the tilt lever on the right side of the Mechanism, position the Keyboard Tray at the desired angle, and retighten the lever. (Pull the lever out to disengage and reset for additional turning.)
  - d) The Mechanism will also swivel to the left or right with a moderate push to the side.