

## ASSEMBLY INSTRUCTIONS

**PARTS LIST for Model 3078 (15-Openings)**

LETTER CODE	DESCRIPTION	QTY.	PART NO.
(A)	Frame (wheels installed)	1	3089-01
(B)	Wheel (installed)	4	3089-25
(C)	Nut (installed)	4	3089-16
(D)	3-Step Base Grid	1	3078-02
(E)	15-opening Shelf Grid	2	3078-03

**PARTS LIST for Model 3089 (24-Openings)**

LETTER CODE	DESCRIPTION	QTY.	PART NO.
(A)	Frame (wheels installed)	1	3089-01
(B)	Wheel (installed)	4	3089-25
(C)	Nut (installed)	4	3089-16
(D)	4-Step Base Grid	1	3089-02
(E)	24-opening Shelf Grid	2	3089-03

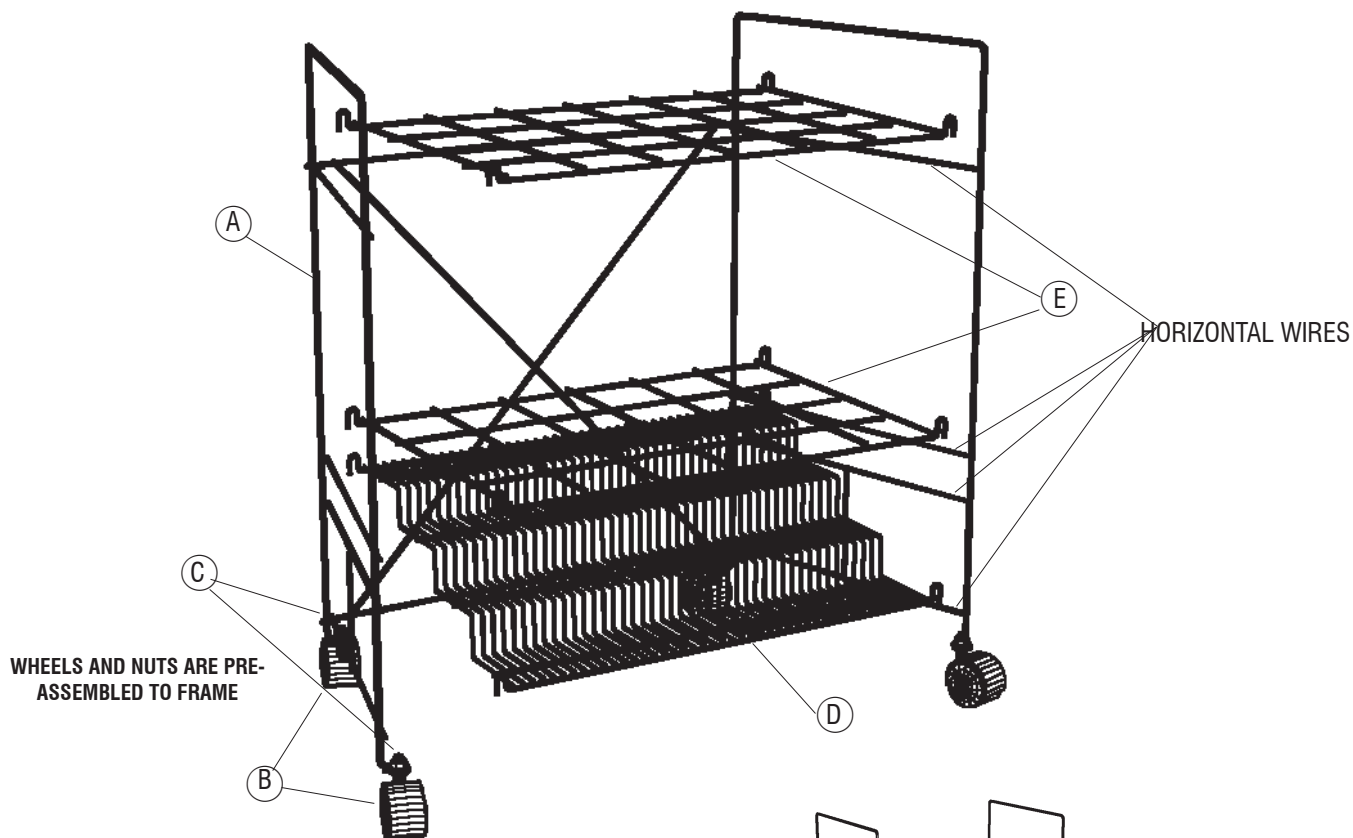

(B) Wheels and (C) Nuts are listed separately for identification, but have already been installed for you.

- 1** Set the (A) Frame (with wheels already attached) upright and swivel the ends so the end panel cross-wires face the **INSIDE** of the unit.
- 2** Place the (D) Base Grid into the bottom of the frame, hooking the low front over the lowest horizontal wire on each end panel, and the high back over the second wire up from the bottom.
- 3** Install one of the (E) Shelf Grids on the center set of horizontal wires, first placing the hooks on one side over one wire, then the hooks on the other side over the other wire.
- 4** Finally, install the remaining shelf grid over the wires second from the top of each end panel, as in step 3.

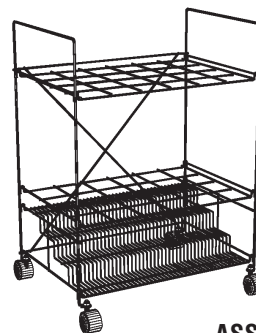

**ASSEMBLED UNIT**  
**MODEL 3089 (24-Openings)**  
**(MODEL 3078 NOT SHOWN)**

For questions or concerns, please call  
**Safco Consumer Hot Line: 1-800-664-0042**  
 available Monday-Friday 8:00 AM to 4:30 PM (Central Time)  
 (English-speaking operators)