

ASSEMBLY INSTRUCTIONS

1 IMPORTANT

- ◆ READ and FOLLOW these instructions carefully!
- ◆ CHECK ALL PACKAGING - there may be parts in it!
- ◆ SORT and COUNT your parts - compare with the list below. If you find problems, refer to the Product Warranty Registration form included with this product.

2 Sort and count your parts!

PARTS LIST			
LETTER CODE	DESCRIPTION	QTY.	PART NO.
A	Caster with Brakes	2	4139-26
B	Caster without Brakes	3	4139-25
C	Base Ring	1	4139-04
D	Lower Wire Ring	4	4139-03
E	Washer	4	4139-21
F	Upper Wire Ring	4	4139-02
G	Wire Compartment	16	4139-01
H	Long Post with Connector	3	4139-06
J	Short Post with Cap	1	4139-07

For questions or concerns, please call
Safco Consumer Hot Line: 1-800-664-0042
 available Monday-Friday 8:00 AM to 4:30 PM (Central Time)
 (English-speaking operators)

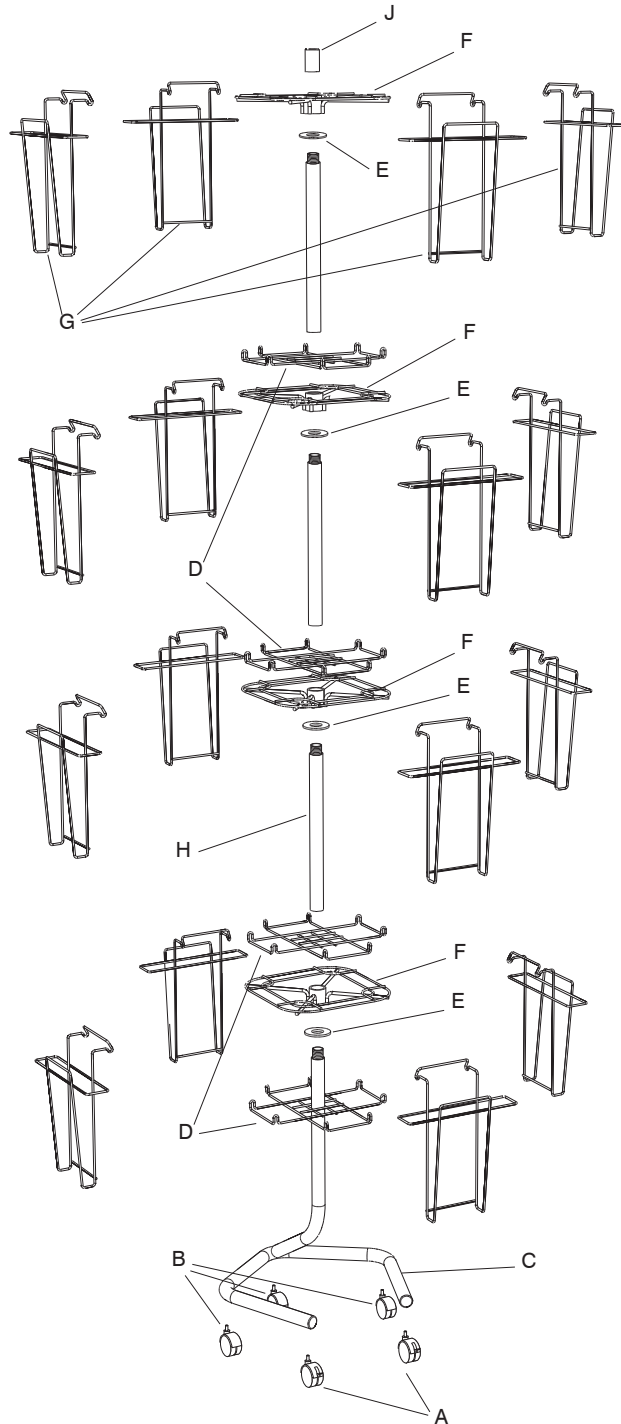

- 3** Insert two A Casters with Brakes into the bottom of the ends of C Base. Insert three B Casters without Brakes into the remaining holes under the Base.

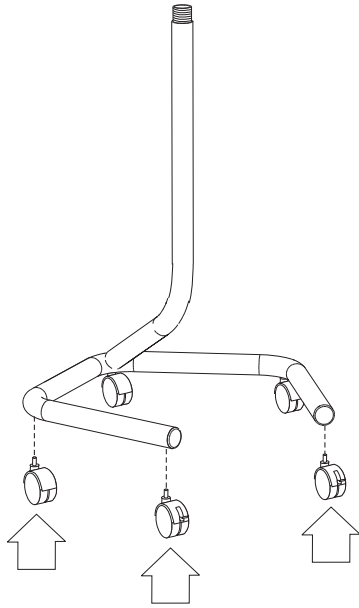

- 4** Place one of the D Lower Wire Rings onto the vertical post of the Base. Position the E Washer onto the vertical post of the base. Screw one of the H Long Posts onto the threaded end of the vertical base to sandwich the Washer in position. **NOTE:** The Lower Wire Ring must be placed on the post BEFORE the Washer and Long Post – it will be connected later.

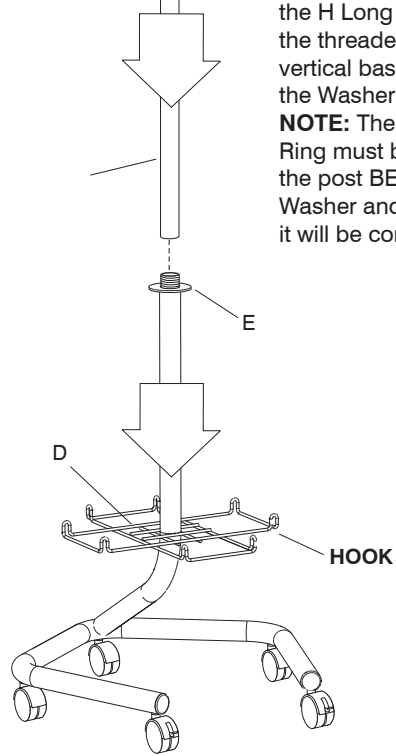

- 5** Slide one F Upper Wire Ring over the post to rest on the washer.

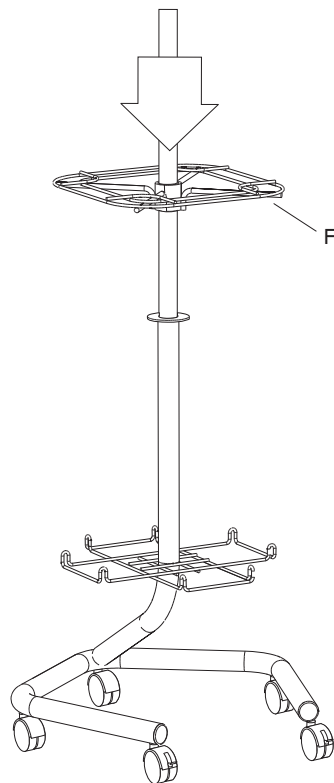

- 6** Tilt one of the G Wire Compartments into one side of the Upper Wire Ring. Be sure to engage the upper compartment hook onto the wire ring. Rotate the compartment so it hangs down vertically. Attach three more Wire Compartments in similar fashion around the Wire Ring.

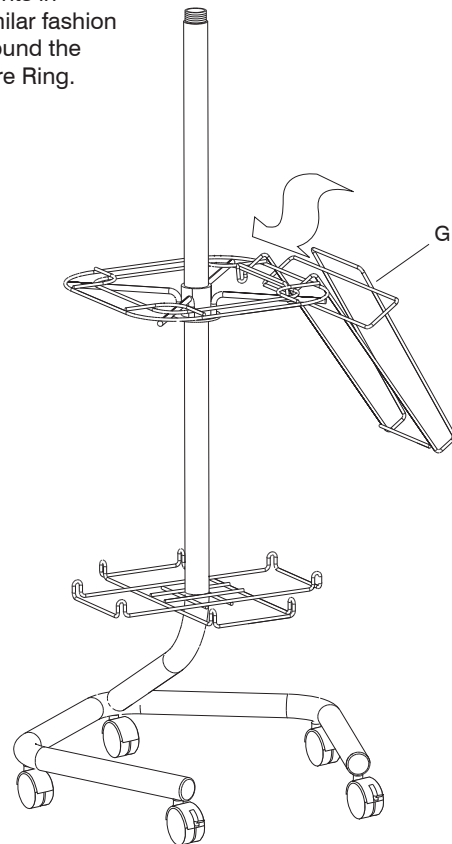

- 7** Raise the D Lower Wire Ring up so that the hooks of the Lower Wire Ring can be situated over the lower, rear wire of the Wire Compartment as shown below.

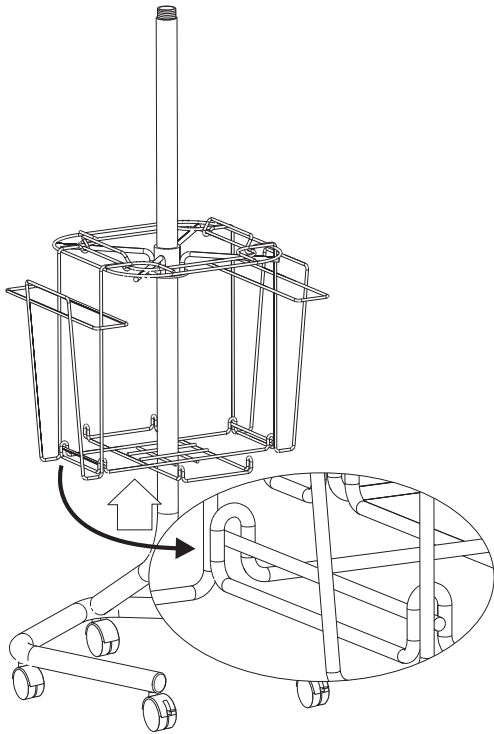

- 8** The first wire compartment assembly is now complete and can be rotated freely on the first Washer.

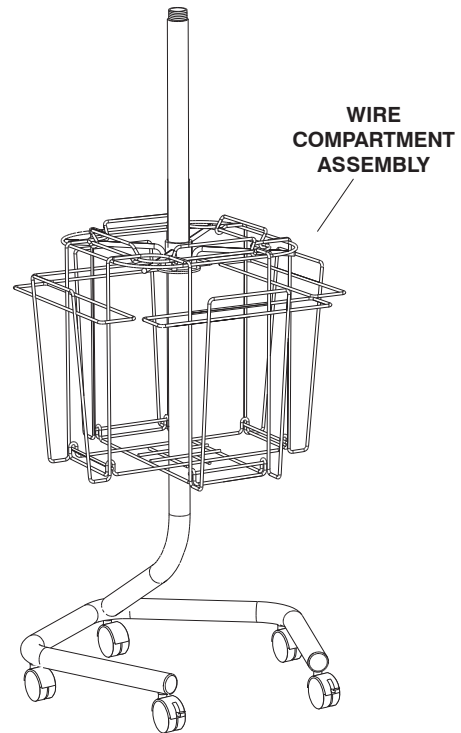

- 9** Repeat instructions 4 thru 8 to assemble the second wire compartment assembly.

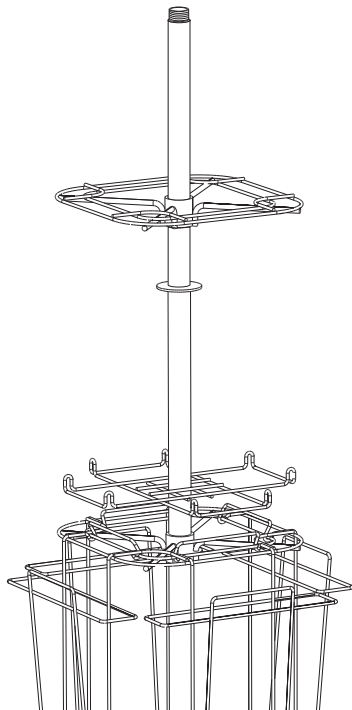

- 10** Repeat instructions 4 thru 8 to assemble the third wire compartment assembly.

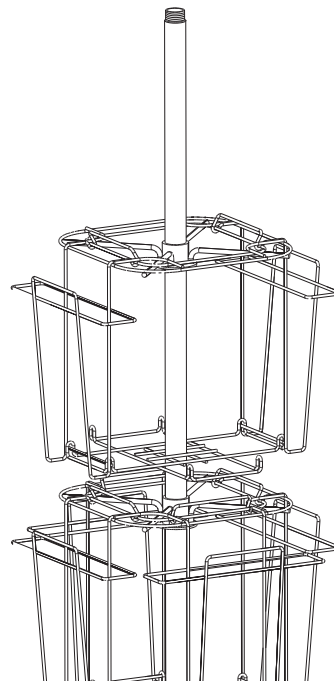

- 11** For the final wire compartment assembly, slide the remaining D Lower Wire Ring onto the vertical post. Position the E Washer onto the vertical post of the base. Screw the J Short Post with Cap onto the threaded end to sandwich the Washer in position. Place the remaining F Upper Wire Ring over the post to rest on the washer.

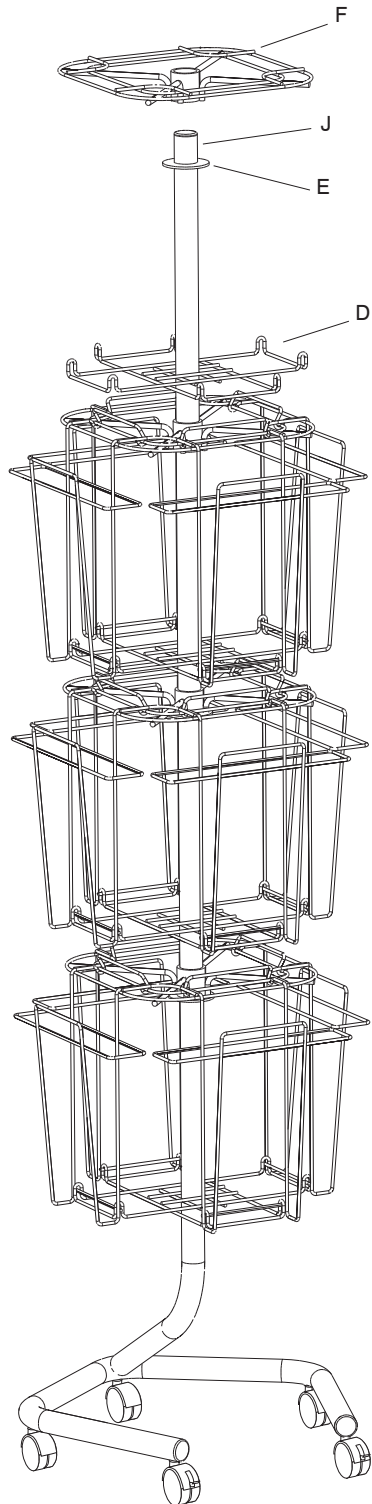

- 12** Repeat steps 6 – 8 to attach the four remaining Wire Compartments to the Upper and Lower Wire Rings. Your Rotary Literature Display Rack is now ready to use. Simply insert your catalogs, magazines or other forms into the wire compartments. The front casters can be “locked” to prevent the unit from rolling.

