

**ASSEMBLY INSTRUCTIONS**  
*INSTRUCTIONS DE MONTAGE*  
**INSTRUCCIONES DE ENSAMBLAJE**

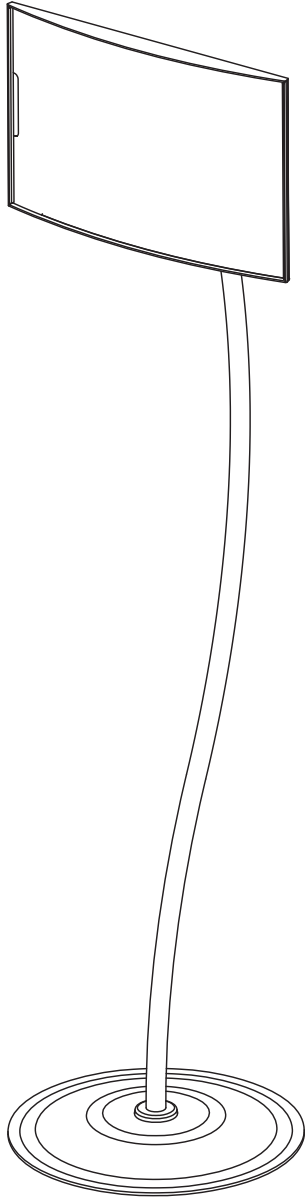

**4174GR**  
**Customizable Rectangular Sign**  
*Personnalisable rectangulaire signe*  
Letrero rectangular personalizable

**PRODUCT WARRANTY REGISTRATION** is available online at: [www.safcoproducts.com](http://www.safcoproducts.com)

• L'INSCRIPTION POUR LA GARANTIE DU PRODUIT est disponible sur l'Internet : [www.safcoproducts.com](http://www.safcoproducts.com)

• EI REGISTRO PARA LA GARANTÍA DEL PRODUCTO está disponible en la Internet: [www.safcoproducts.com](http://www.safcoproducts.com)





For questions or concerns, please call **1-800-664-0042**  
available Monday-Friday 7:00 AM to 6:00 PM (Central Time) (English-speaking operators)

Si vous avez des questions pour poser ou les préoccupations pour exprimer, connecter **au 1-800-664-0042** de 7H00 à 18H00 (Heure centrale) (Opérateurs de langue anglaise)

Si usted tiene preguntas o preocupaciones, por favor llame **1-800-664-0042** de 7:00 AM a 6:00 PM (Hora Central) (Operadores que hablan inglés)





TOOLS REQUIRED : ADJUSTABLE WRENCH.

PARTS LIST			
CODE	DESCRIPTION	QTY	PART NO.
(A)	Post	1	4169-01GR
(B)	Base	1	4169-02GR
(C)	Sign Back	1	4169-03GR
(D)	Clear Sheet Protector	1	4169-04CL

HARDWARE PACK 4169-19NC			
<b>E</b>	 Knob Qty.: 1 #4169-07NC	<b>F</b>	 Washer Qty.: 1 #4169-21NC
<b>G</b>	 Lock Washer Qty.:1 #4169-22NC	<b>H</b>	 Screw Qty.: 1 #4169-23NC





OUTILS REQUIS : CLEF RÉGLABLE.

LISTE DES PIÈCES			
CODE	DESCRIPTION	QUANTITÉ	N° DE PIÈCE
(A)	Poteau	1	4169-01GR
(B)	Base	1	4169-02GR
(C)	Signe arrière	1	4169-03GR
(D)	Feuille protecteur transparente	1	4169-04CL

Paquet matériel 4169-19NC			
<b>E</b>	 Pomo Qté.: 1	<b>F</b>	 Rondelle Qté.: 1 #4169-21NC
<b>G</b>	 Rondelle fendue Qté.:1#4169- #4169-22NC	<b>H</b>	 Vis Qté.: 1 #4169-23NC

HERRAMIENTAS REQUERIDAS: LLAVE AJUSTABLE.

LISTA DE PIEZAS			
CODIGO	DESCRIPCIÓN	CANTIDAD	NO. DE PIEZA
(A)	Poste	1	4169-01GR
(B)	Base	1	4169-02GR
(C)	Delantera de la letrero	1	4169-03GR
(D)	Clara hoja protectora	1	4169-04CL

Paquete material 4169-19NC			
<b>E</b>	 Poignée Cant.: 1 #4169-07NC	<b>F</b>	 Arandela Cant.: 1 #4169-21NC
<b>G</b>	 Arandela de seguridad Cant.:1 #4169-22NC	<b>H</b>	 Tornillo Cant.: 1 #4169-23NC

**NOTE: Signboard not included.**

*Noter: Panneau non inclus.*

Note: Señal no incluidos.

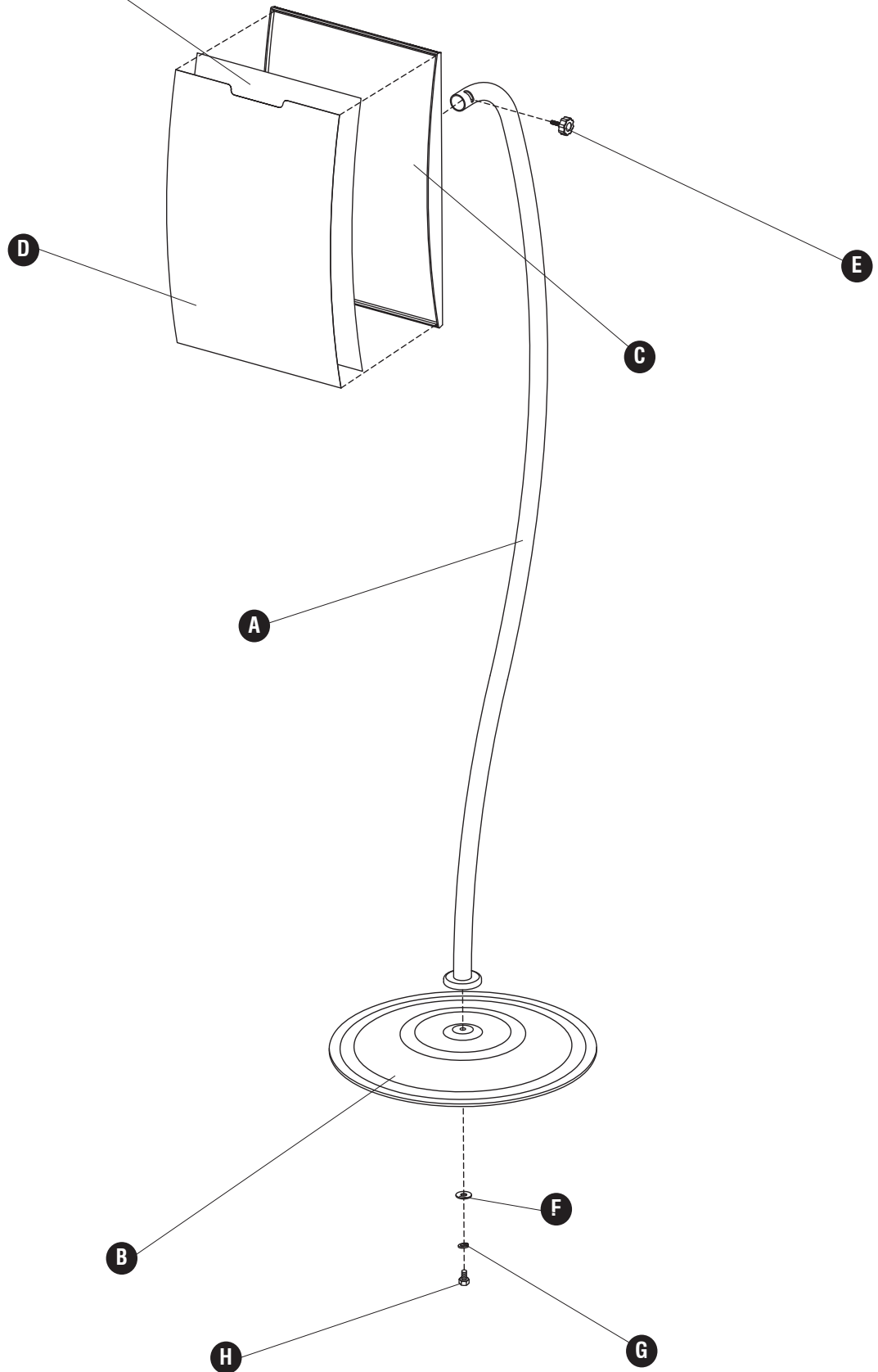

1

F



G



H

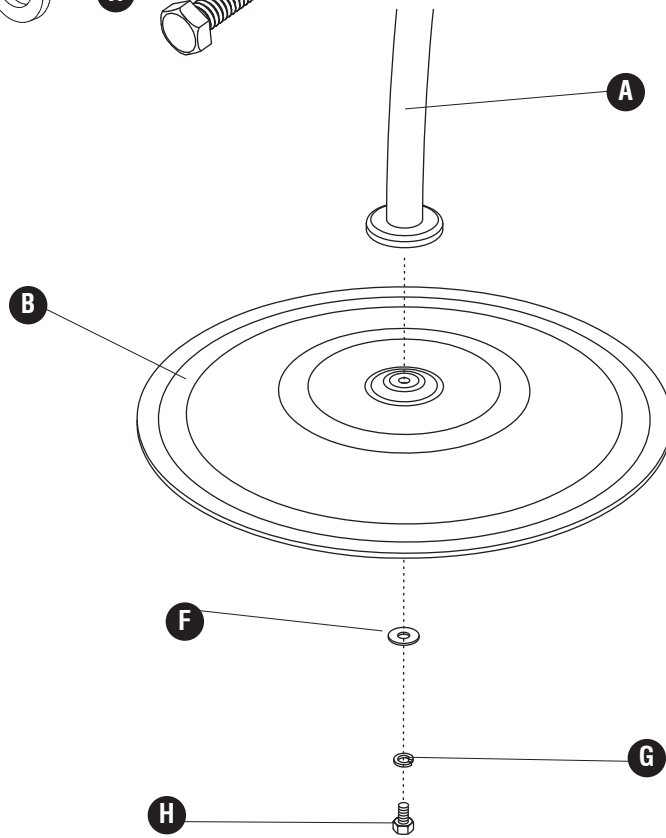

2

E

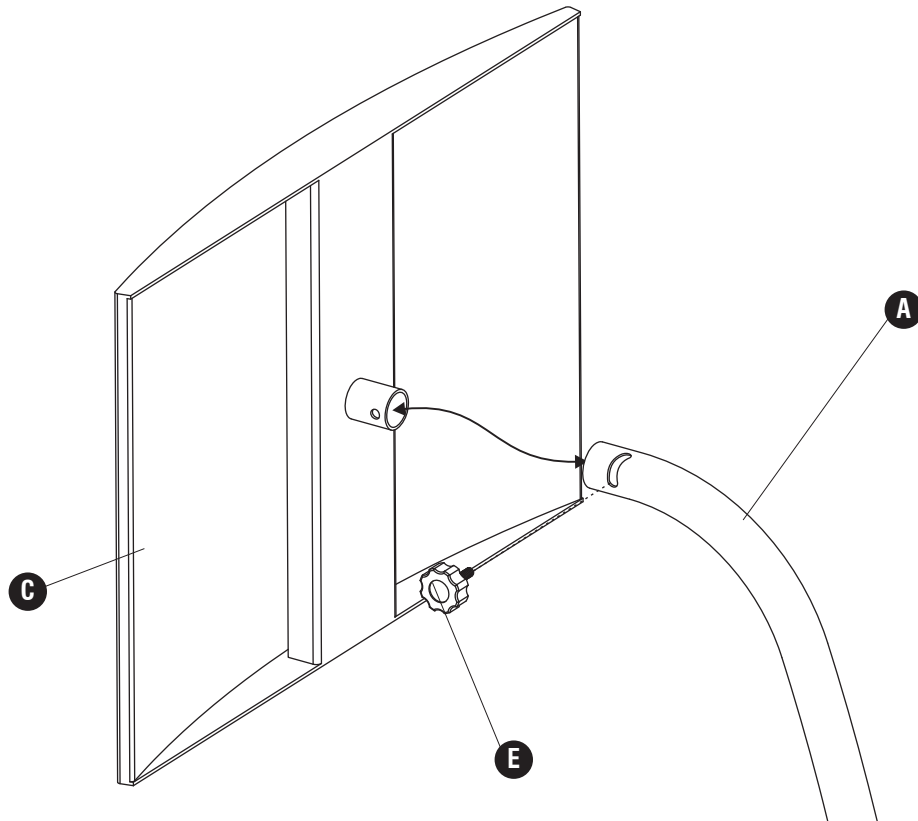

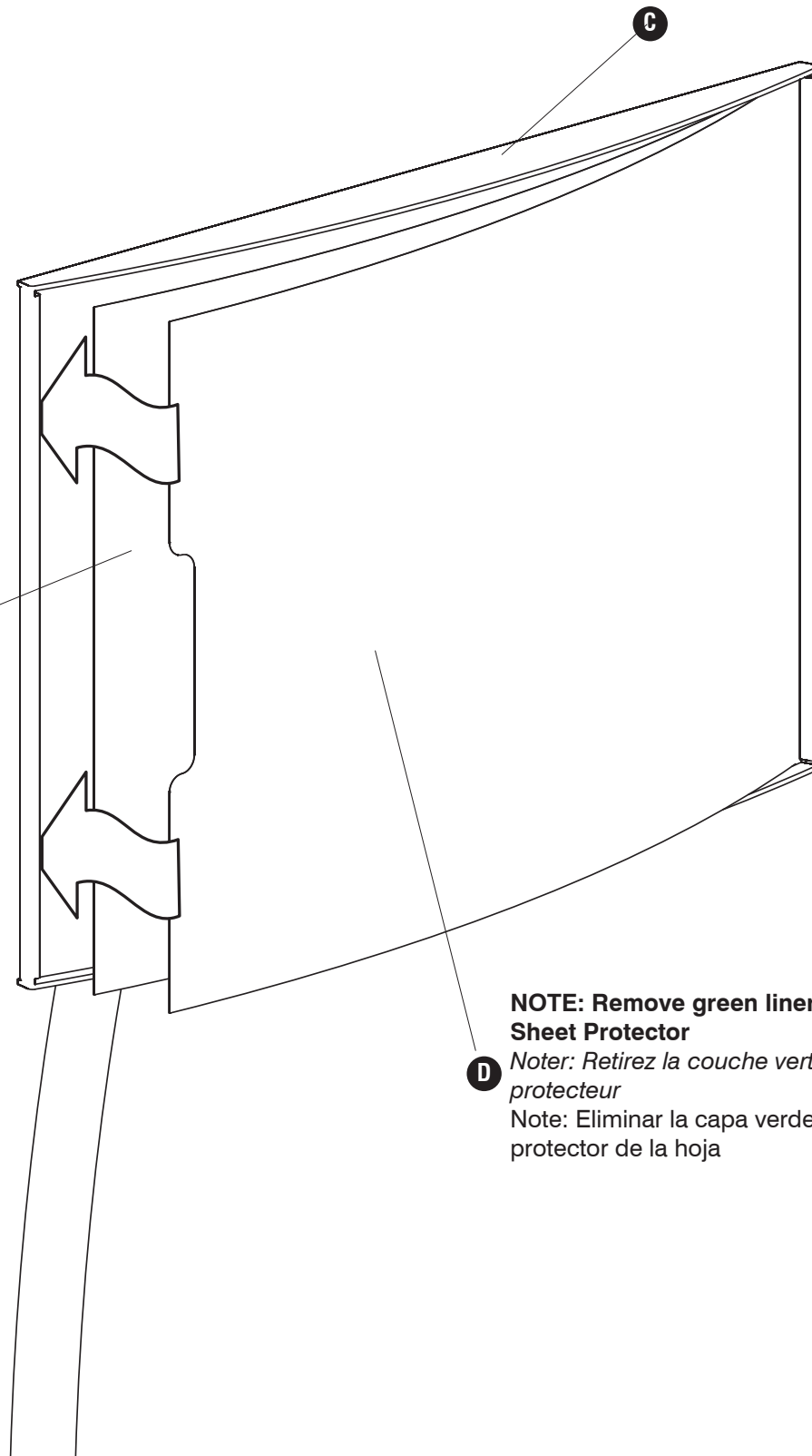

**Signboard (not included)**  
*Panneau ( non inclus )*  
Note: Señal (no incluidos)

**NOTE: Remove green liner from Sheet Protector**  
*Noter: Retirez la couche verte du feuille protecteur*  
Note: Eliminar la capa verde del protector de la hoja