

PRODUCT WARRANTY REGISTRATION is available online at: [www.safcoproducts.com](http://www.safcoproducts.com)  
 PARTS LIST

LETTER CODE	DESCRIPTION	QTY.	PART NO.
-------------	-------------	------	----------

**Common Hardware**

(A)	Lock	1	5023-12
(B)	Key	2	5023-10
(C)	Drawer Glide, Set of 4	1	5023-14
(D)	Gas Lift	2	5023-11
(E)	Stabilizer Knob	4	5023-24
(F)	Caster	4	5023-25
(G)	Leveler	4	5023-26
(H)	Index/Out Card	1	6554-01

**Models 5023, 5024**

(J)	Drawing Selector (for 5023)	1	6555-01
(J)	Drawing Selector (for 5024)	1	6556-01
(K)	Selector Silencer	1	6555-05
(L)	Hanger Knob	2	5023-23
(M)	Hanger Slide Bar	2	5023-15
(N)	Hanger Spring	2	5023-31
(O)	Hex Nut	2	5023-21

**Model 5025**

(J)	Drawing Selector (for 5025)	1	6557-01
(K)	Selector Silencer	1	6557-05
(L)	Hanger Knob	4	5023-23
(M)	Hanger Slide Bar	4	5023-15
(N)	Hanger Spring	4	5023-31
(O)	Hex Nut	4	5023-21

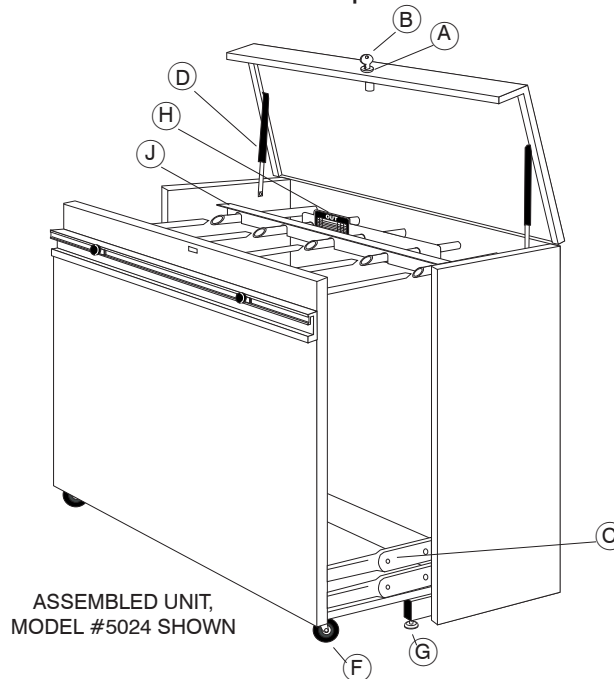

ASSEMBLED UNIT,  
 MODEL #5024 SHOWN

TOOLS REQUIRED: WRENCH (Included)

## OPERATING INSTRUCTIONS

### 1 HOW TO LEVEL THE MASTERFILE

The MasterFile pins and posts are aligned by leveling, as follows. After placing your MasterFile in position, raise lid and **pull the drawer completely open**.

Unscrew and remove (E) Stabilizer Knobs at bottom of cabinet. Slide the Stabilizer Tube out to align holes with one of the numbered holes shown. Use hole #2 for vellum; hole #3 for film up to 3-mil; hole #4 for film over 3-mil. Or, set at hole #4 for all applications. Insert Stabilizer Knob into appropriate hole and tighten.

**Do not pull the Stabilizer Tube out beyond hole location #4.**

Using the wrench supplied with the cabinet, unscrew the rear (G) Levelers until the back of the unit is at least 1/4" off floor. Then, unscrew one of the front levelers until front corner of the cabinet nearest that leveler is 1/4" to 3/8" off floor. Unscrew other front leveler until ends of pins align with open ends of posts.

**Close drawer completely.** Be sure to level the unit side-to-side and front-to-back.

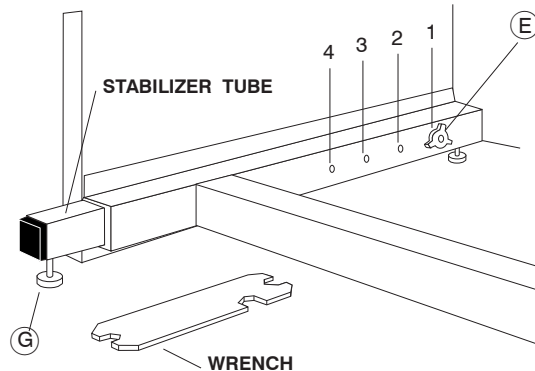

For questions or concerns, please call  
**Safco Consumer Hot Line: 1-800-664-0042**  
 available Monday-Friday 8:00 AM to 4:30 PM (Central Time)

**NOTE:** If the drawer is jammed, the drawer slides need to be re-cycled. Pull hard on drawer forcing it open. Completely open and shut drawer two or three times. Check slide lubrication. Drawer should now operate smoothly.

### 2

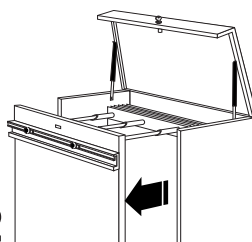

When filing or retrieving, roll the drawer out of the main cabinet to a point where about two inches of the pins remain in the posts of the cabinet.

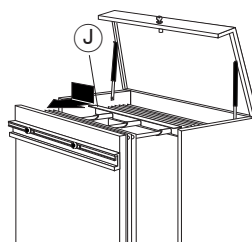

Insert the (J) Drawing Selector behind the desired drawing so the notches ride on cabinet posts. Use the Selector to move the groups of drawings from posts to pins.

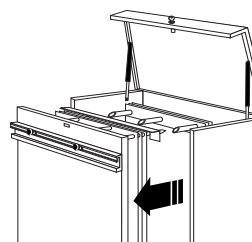

When selected drawings are on the pins, roll the entire drawer away from the cabinet **as far as it will go**, disengaging the pins from the posts.

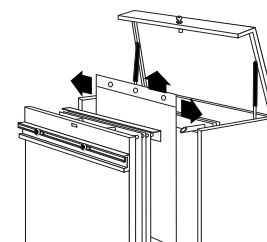

The space between pins and posts permit filing or removal without rubbing on adjacent drawings. Remove drawings from the side or the top. Always handle by carrier strips - not drawings. Drawings transfer to posts when cabinet is closed.

**NOTE: ALL MASTERFILES MUST BE LEVELED SIDE-TO-SIDE AND FRONT-TO-BACK. BEFORE RELOCATING UNIT, POSITION LEVELERS FULLY UPWARD.**

### 3 SHEET HANGER KNOBS

Assemble sheet hanger knob as shown. Holding (L) Hanger Knob and (N) Hanger Spring between thumb and forefinger, depress spring and insert (M) Hanger Slide into grooved channel. To move sheet hanger knob in channel, push inward on black knob and move into position. Assemble remaining knobs, insert and space accordingly. Knobs hold up to 25 sheets.

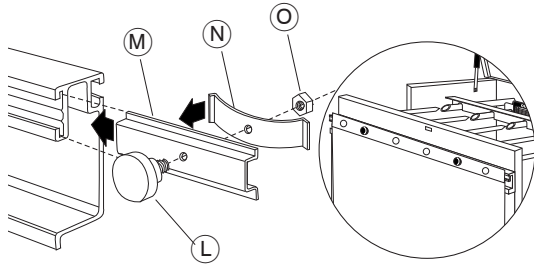

### 4 Here are a few tips to keep your MasterFile in top working condition:

- Occasionally dust the surfaces of the file.
- A dry spray lubricant may be used (**only**) on the drawer slides to maintain smooth and easy operation.
- **CAUTION:** Pins and Posts **DO NOT** require lubrication. Use of lubrication will be **HARMFUL** to your drawings.
- Always handle originals by the carrier strip.
- Always file on the Pins.
- Always pull the drawer **completely** open to load drawings, then completely close the drawer.
- Avoid overloading. Refer to MasterFile Sheet Capacity Guide on inner lid of unit.
- Never leave sheets at the end of the pins or posts of an open file because the weight can cause bending to occur.

## ACCESSORIES

### 5 INDEX/OUT GUIDE

Each guide serves as a 3-position index guide for locating, retrieving or filing individual sheets or job groupings; or, as an out guide to identify documents removed from the file. They are prepunched for easy use in all MasterFile's.

One guide with one index and out label is provided. Additional Index/Out Guides are available for purchase if desired, in standard packs of 20 guides, 20 index labels and 20 out labels per box.

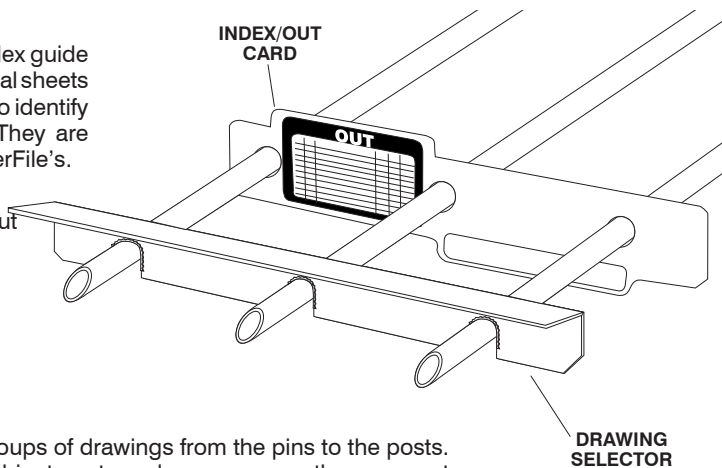

### 6 DRAWING SELECTOR

Use the drawing selector to move groups of drawings from the pins to the posts. The notched selector rides on the cabinet posts and assures smooth movement of drawings. One drawing selector is provided with each MasterFile; additional selectors are available for purchase if desired.

For less noise and smoother operation, install plastic silencers in each notch of the Drawing Selector as shown below.

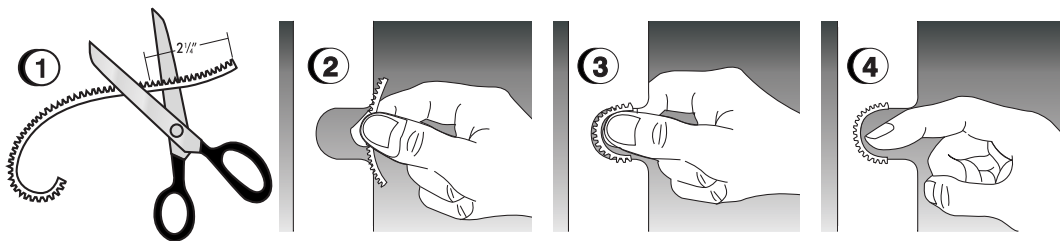

### 7 CARRIER STRIPS

Position center hole at top/center of document, then trim to fit paper  
Peel backing strip away and affix to paper edge.

One assorted set of carrier strips is provided with each MasterFile; additional rolls of carrier strips in handy dispenser boxes are available for purchase if desired.

**NOTE:** Vellum may shrink when moved from a humid to a dry environment. Care should be taken to apply carrier strips to stabilized vellum in a dry environment.

