

**ASSEMBLY INSTRUCTIONS**  
**INSTRUCCIONES DE MONTAJE**  
**INSTRUCCIONES DE ENSAMBLAJE**

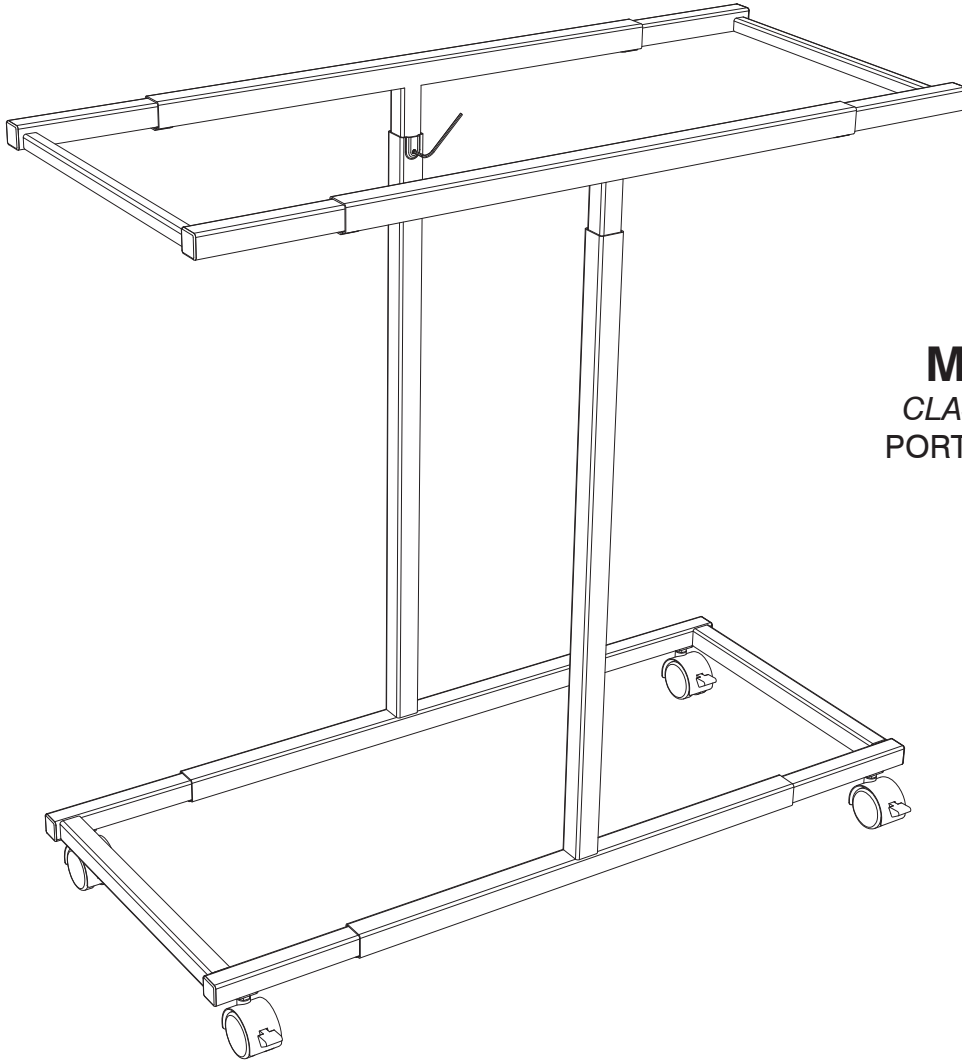

**5059**  
**Mobile Vertical File**  
*CLASSEUR VERTICAL ( MOBILE )*  
*PORTAPLANOS VERTICAL (MÓVIL)*

**PRODUCT WARRANTY REGISTRATION** is available online at: [www.safcoproducts.com](http://www.safcoproducts.com)

• L'INSCRIPTION POUR LA GARANTIE DU PRODUIT est disponible sur l'Internet : [www.safcoproducts.com](http://www.safcoproducts.com)

• EI REGISTRO PARA LA GARANTÍA DEL PRODUCTO está disponible en la Internet: [www.safcoproducts.com](http://www.safcoproducts.com)

For questions or concerns, please call **1-800-664-0042**  
available Monday-Friday 7:00 AM to 6:00 PM (Central Time) (English-speaking operators)





Si vous avez des questions pour poser ou les préoccupations pour exprimer, connecter **au 1-800-664-0042** de 7H00 à 18H00 (Heure centrale) (Opérateurs de langue anglaise)

Si usted tiene preguntas o preocupaciones, por favor llame **1-800-664-0042** de 7:00 AM a 6:00 PM (Hora Central) (Operadores que hablan inglés)

**TOOLS REQUIRED : RUBBER Mallet; ALLEN WRENCH (INCLUDED); WRENCH (INCLUDED).**

### PARTS LIST





CODE	DESCRIPTION	QTY	PART NO.
(A)	Lower T-Frame	2	5059-01TS
(B)	Upper T-Frame	2	5059-02TS
(D)	Lower U-Frame	2	5059-03TS

HARDWARE PACK 5059 -19NC	
<b>E</b>  Set screw Qty.: 10 #5059-27NC	<b>F</b>  Allen Wrench Qty.: 1 #5059-24NC
<b>G</b>  Wrench Qty.:1 #5059-33NC	<b>H</b>  Locking Caster Qty.: 4 #5059-26NC

**OUTILS REQUIS : MAILLET À TÊTE EN CAOUTCHOUC;  
CLEF ALLEN (INCLUDE); CLEF (INCLUDE).**

### LISTE DES PIÈCES

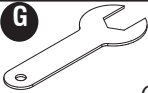



CODE	DESCRIPTION	QUANTITÉ	N° DE PIECE
(A)	Bâti en T inférieure	2	5059-01TS
(B)	Bâti en T supérieure	2	5059-02TS
(D)	Bâti en U inférieure	2	5059-03TS

Paquet matériel 5059 -19NC	
<b>E</b>  Vis Qté.: 10 #5059-27NC	<b>F</b>  Clef Allen Qté.: 1 #5059-27NC
<b>G</b>  Clef Qté.:1 #5059-33NC	<b>H</b>  Roulette avec frein Qté.: 4 #5059-26NC

**HERRAMIENTAS REQUERIDAS: MAZO DE GOMA; LLAVE ALLEN (INCLUIDA); LLAVE (INCLUIDA).**

### LISTA DE PIEZAS

CODIGO	DESCRIPCIÓN	CANTIDAD	NO. DE PIEZA
(A)	Marco en "T" inferior	2	5059-01TS
(B)	Marco en "T" superior	2	5059-02TS
(C)	Marco en "U" inferior	2	5059-03TS
(D)	Marco en "U" superior	2	5059-04TS

Paquete material 5059 -19NC	
<b>E</b>  Tornillo Cant.: 10 #5059-27NC	<b>F</b>  Llave Allen Cant.: 1 #5059-27NC
<b>G</b>  Llave Cant.:1 #5059-33NC	<b>H</b>  Rueda con freno Cant.: 4 #5059-26NC

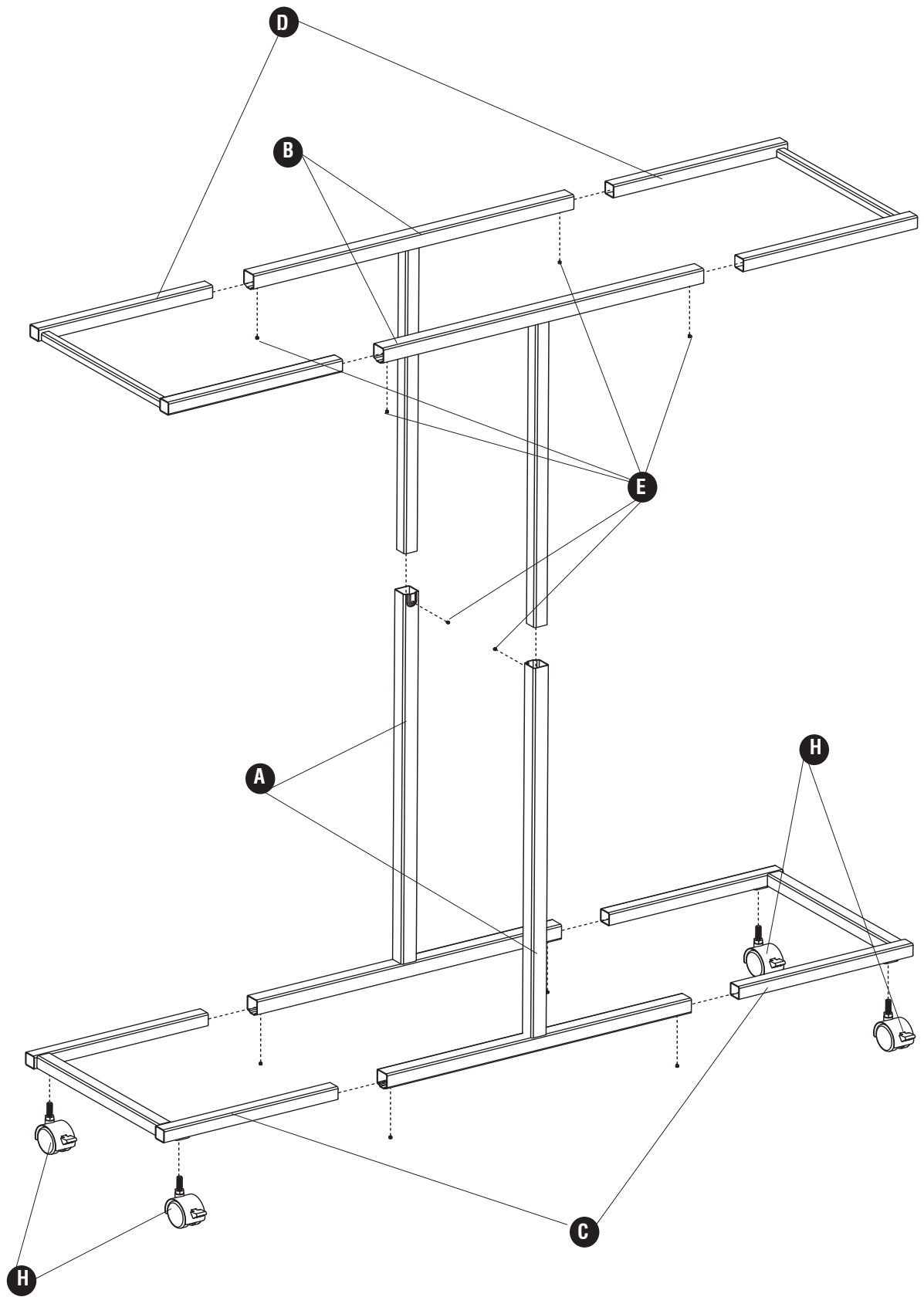

**1** **E** (4)

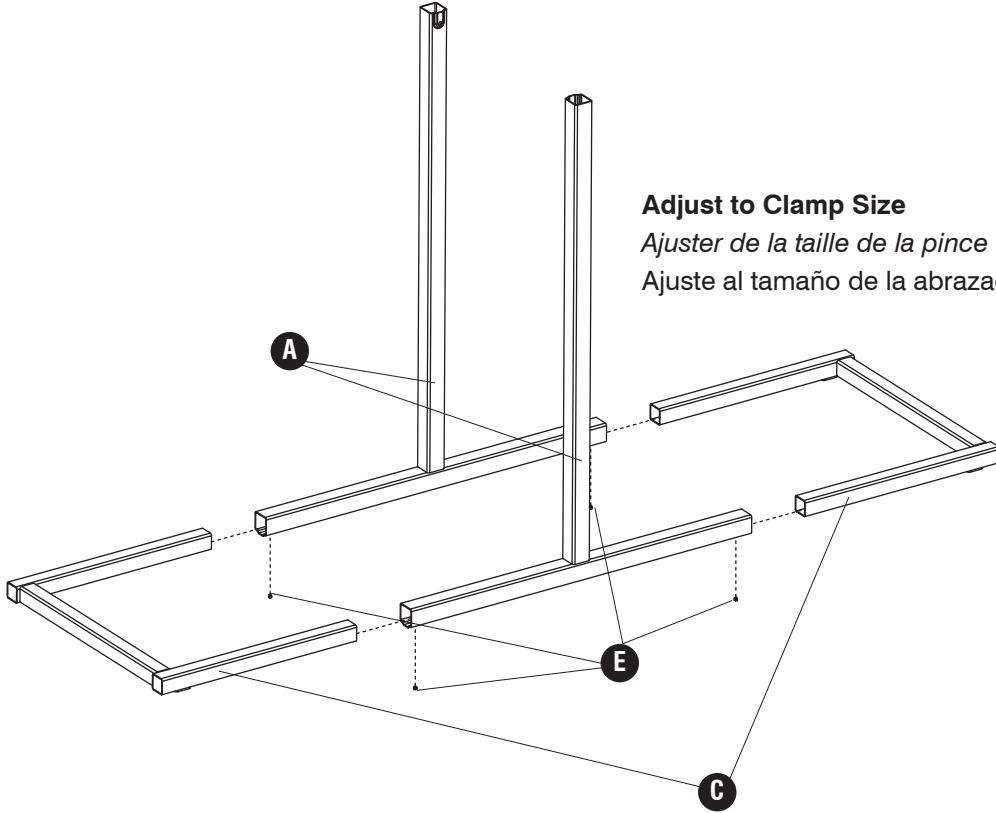

**Adjust to Clamp Size**  
*Ajuster de la taille de la pince*  
Ajuste al tamaño de la abrazadera

**2** **H** (4)



(1)

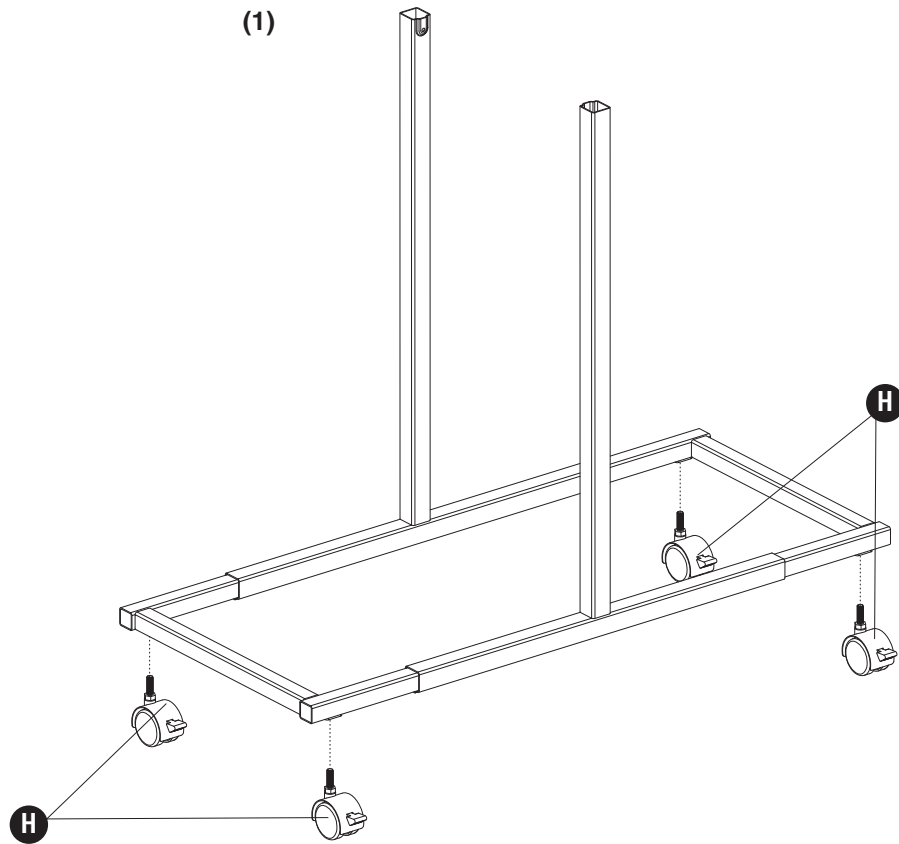

3

E



(4)

**Adjust to Clamp Size**

*Ajuster de la taille de la pince*

*Ajuste al tamaño de la abrazadera*

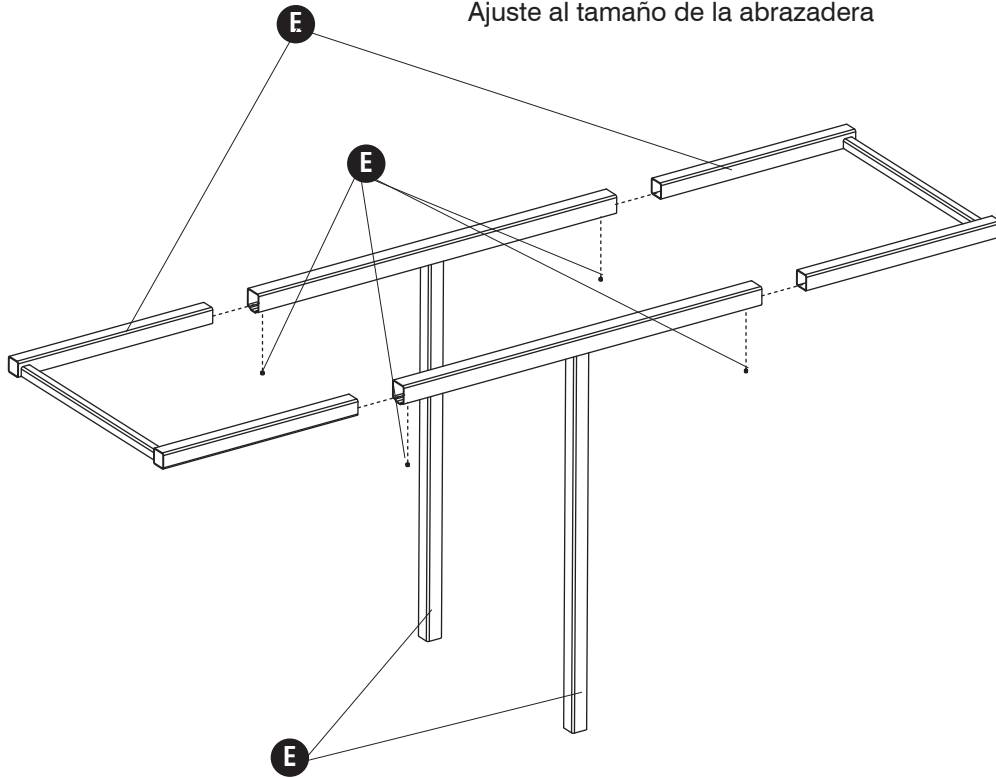

4

E



(2)

**Adjust to Paper Size**

*Ajuster à la taille du papier*

*Ajustar al tamaño del papel*

