

ASSEMBLY INSTRUCTIONS
INSTRUCTIONS DE MONTAGE
INSTRUCCIONES DE ENSAMBLAJE

9274

E-Z Stor[®]

Printout Organizer (30 Compartments)

Classeur de Documents (à 30 Cases)

Casillero para Publicaciones (30 Compartimientos)

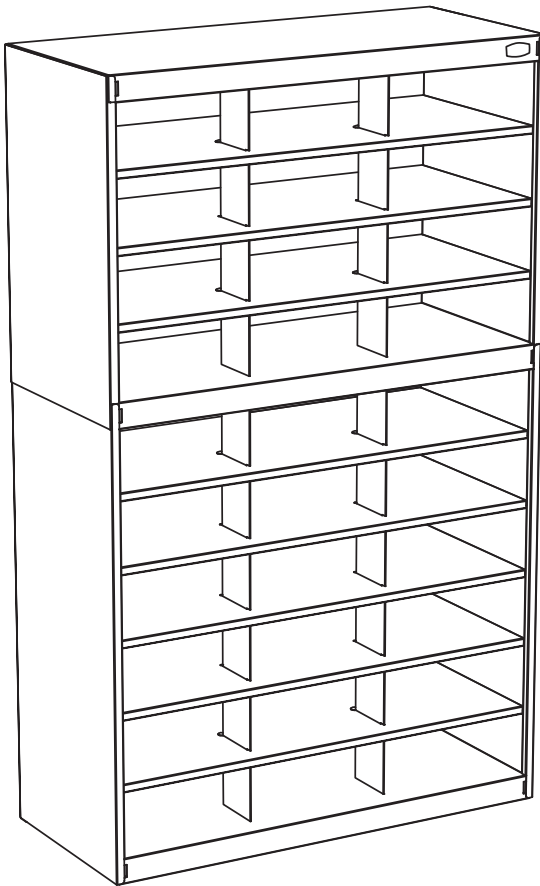

PRODUCT WARRANTY REGISTRATION is available online at: www.safcoproducts.com

• L'INSCRIPTION POUR LA GARANTIE DU PRODUIT est disponible sur l'Internet : www.safcoproducts.com

• El REGISTRO PARA LA GARANTÍA DEL PRODUCTO está disponible en la Internet: www.safcoproducts.com

For questions or concerns, please call **1-800-664-0042**
available Monday-Friday 7:00 AM to 6:00 PM (Central Time) (English-speaking operators)

Si vous avez des questions pour poser ou les préoccupations pour exprimer, connecter **au 1-800-664-0042** de 7H00 à 18H00 (Heure centrale) (Opérateurs de langue anglaise)



Si usted tiene preguntas o preocupaciones, por favor llame **1-800-664-0042** de 7:00 AM a 6:00 PM (Hora Central) (Operadores que hablan inglés)

TOOLS REQUIRED: Phillips Screwdriver

PARTS LIST

CODE	DESCRIPTION	QTY.	PART NO.
(A)	2" Shelf, Plain	2	9254-51GR
(B)	2" Shelf, with Label	1	9254-52GR
(C)	5/8" Shelf	8	9254-53GR
(D)	Lower Outer Side Panel	2	9264-54GR
(E)	Upper Outer Side Panel	2	9274-54GR
(F)	Lower Inner Side Panel	2	9264-55GR
(G)	Upper Inner Side Panel	2	9254-55GR
(H)	Lower Fiber Back Panel	1	9221-57BL
(I)	Upper Fiber Back Panel	1	9211-57BL
(J)	Lower Divider	2	9264-56GR
(K)	Upper Divider	2	9254-56GR
(L)	Hardware Pack	1	9274-69NC

HARDWARE PACK 9274-69NC



M 	N 	O 
Plastic Button Qty.: 8 #9211-61NC	Screw Qty.: 12 #9211-77NC	Shim Qty.: 2 #9231-62NC

OUTILS REQUIS : Tournevis à pointe cruciforme

LISTE DES PIÈCES

CODE	DESCRIPTION	QUANTITÉ	N° DE PIECE
(A)	Tablette 5 cm (2 po), ordinaire	2	9254-51GR
(B)	Tablette 5 cm (2 po), avec étiquette	1	9254-52GR
(C)	Tablette 1.5 cm (5/8 po)	8	9254-53GR
(D)	Panneau latéral extérieur inférieur	2	9264-54GR
(E)	Panneau latéral extérieur supérieur	2	9274-54GR
(F)	Panneau latéral intérieur inférieur	2	9264-55GR
(G)	Panneau latéral intérieur supérieur	2	9254-55GR
(H)	Panneau de fond de fibres inférieur	1	9221-57BL
(I)	Panneau de fond de fibres supérieur	1	9211-57BL
(J)	Séparateur inférieur	2	9264-56GR
(K)	Séparateur supérieur	2	9254-56GR
(L)	Paquet Matériel	1	9274-69NC

PAQUET MATÉRIEL 9274-69NC



M 	N 	O 
Bouton en plastique Qte.: 8 #9211-61NC	Vis Qte.: 12 #9211-77NC	Cale d'épaisseur Qte.: 2 #9231-62NC

HERRAMIENTAS REQUERIDAS: Destornillador Phillips®

LISTA DE PIEZAS

CODIGO	DESCRIPCIÓN	CANTIDAD	NO. DE PIEZA
(A)	Repisa de 5 cm (2"), llano	2	9254-51GR
(B)	Repisa de 5 cm (2"), con la etiqueta	1	9254-52GR
(C)	Repisa de 1.5 cm (5/8")	8	9254-53GR
(D)	Panel exterior lateral inferior	2	9264-54GR
(E)	Panel exterior lateral superior	2	9274-54GR
(F)	Panel interior lateral inferior	2	9264-55GR
(G)	Panel interior lateral superior	2	9254-55GR
(H)	Panel posterior de fibra inferior	1	9221-57BL
(I)	Panel posterior de fibra superior	1	9211-57BL
(J)	Separador inferior	2	9264-56GR
(K)	Separador superior	2	9254-56GR
(L)	Paquete Material	1	9274-69NC

PAQUETE MATERIAL 9274-69NC

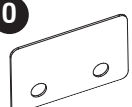
M 	N 	O 
Botón de plástico Cant.: 8 #9211-61NC	Tornillo Cant.: 12 #9211-77NC	Cuña Cant.: 2 #9231-62NC

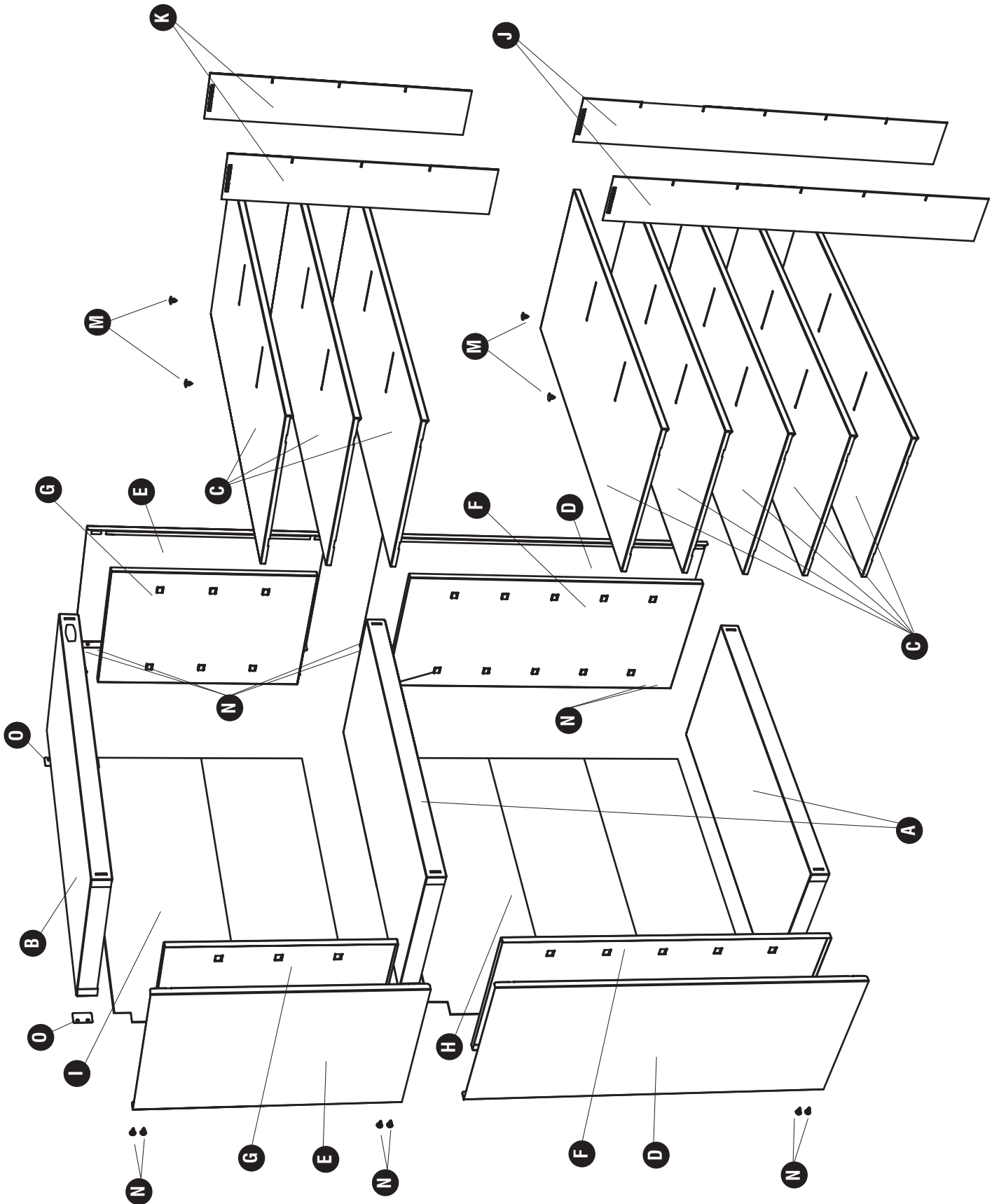

1 **N**  (4)

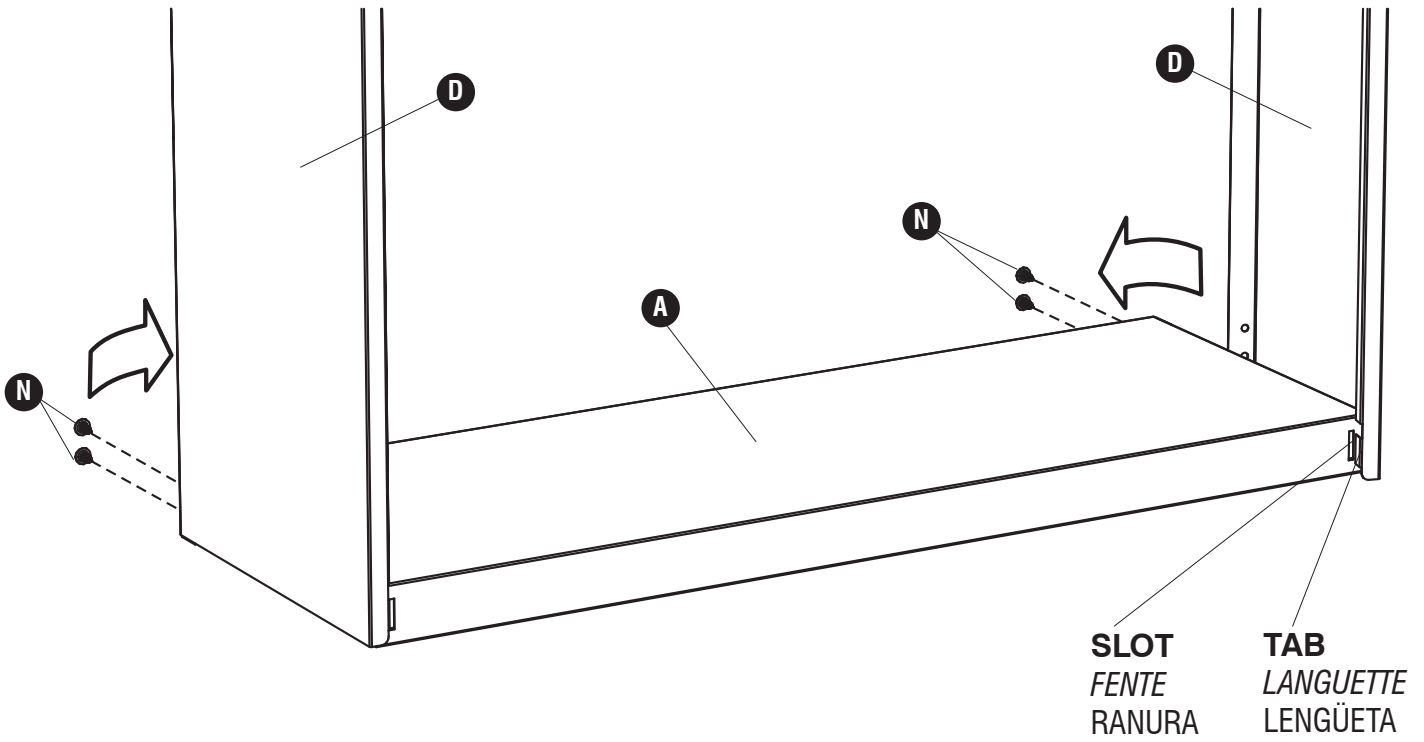

2

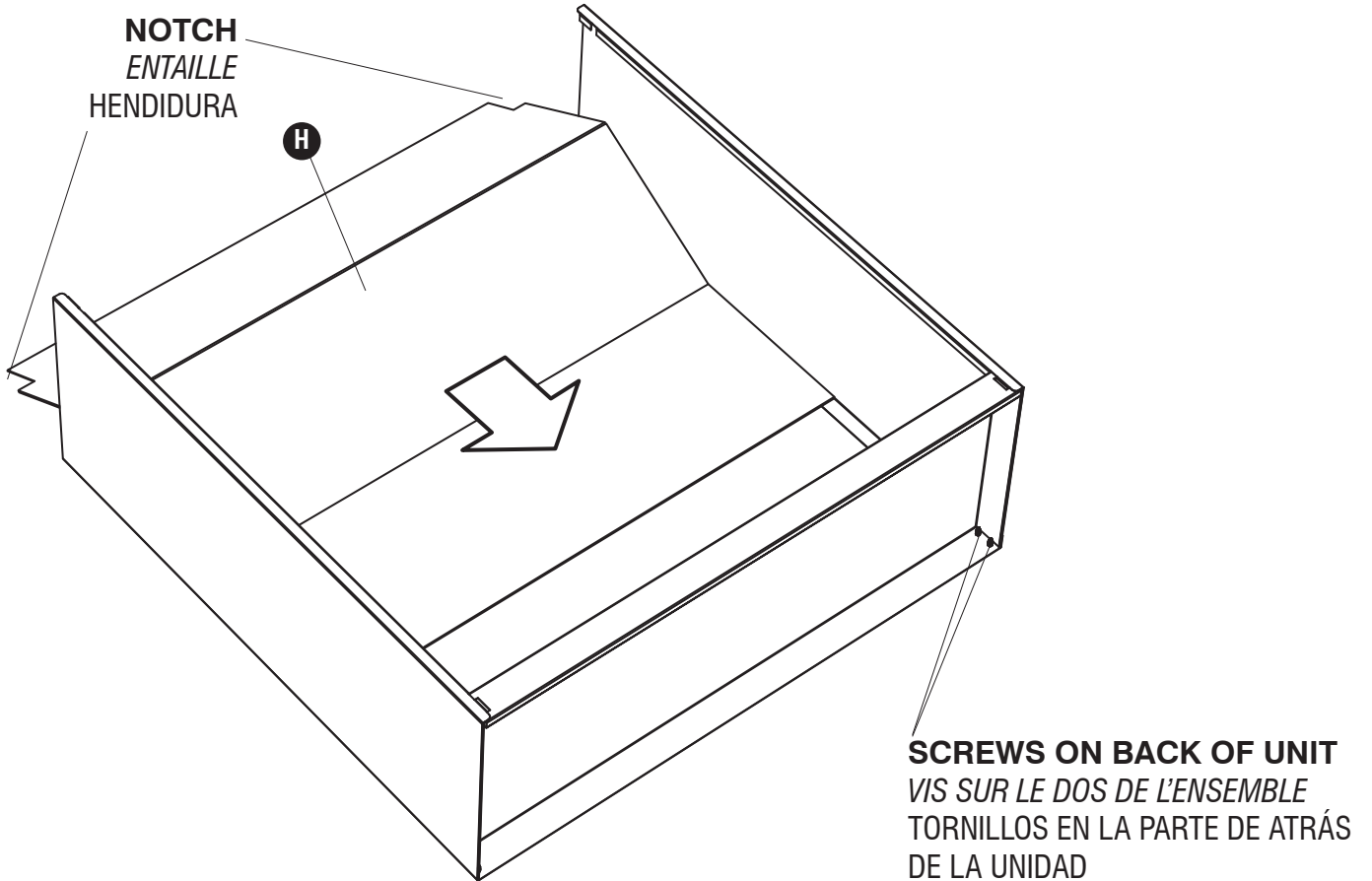

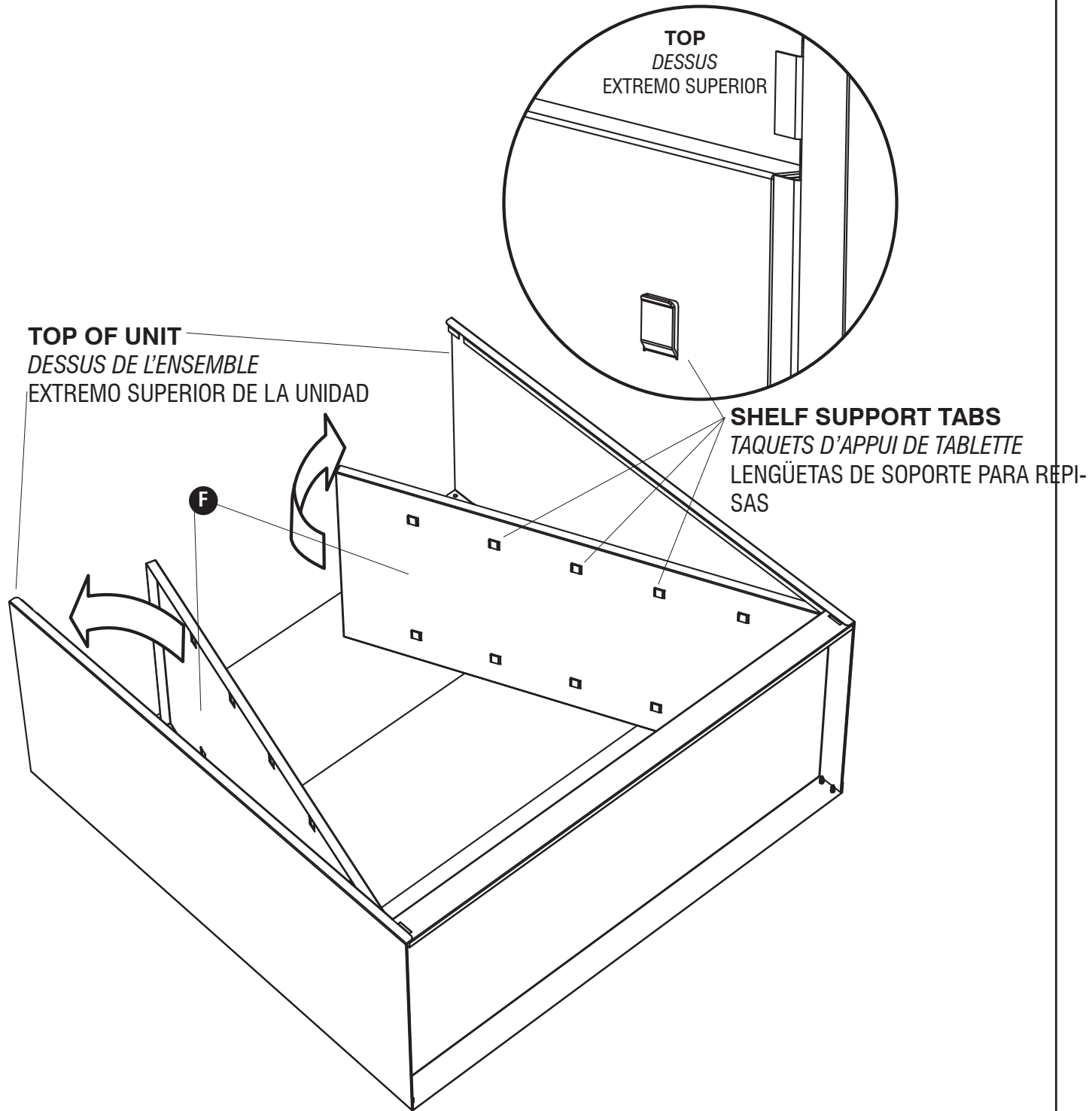

4

SHELF NOTCH
ENTAILLE DE TABLETTE
HENDIDURA DE LA REPISA

SHELF SUPPORT TABS
TAQUETS D'APPUI DE TABLETTE
LENGÜETAS DE SOPORTE PARA REPISAS

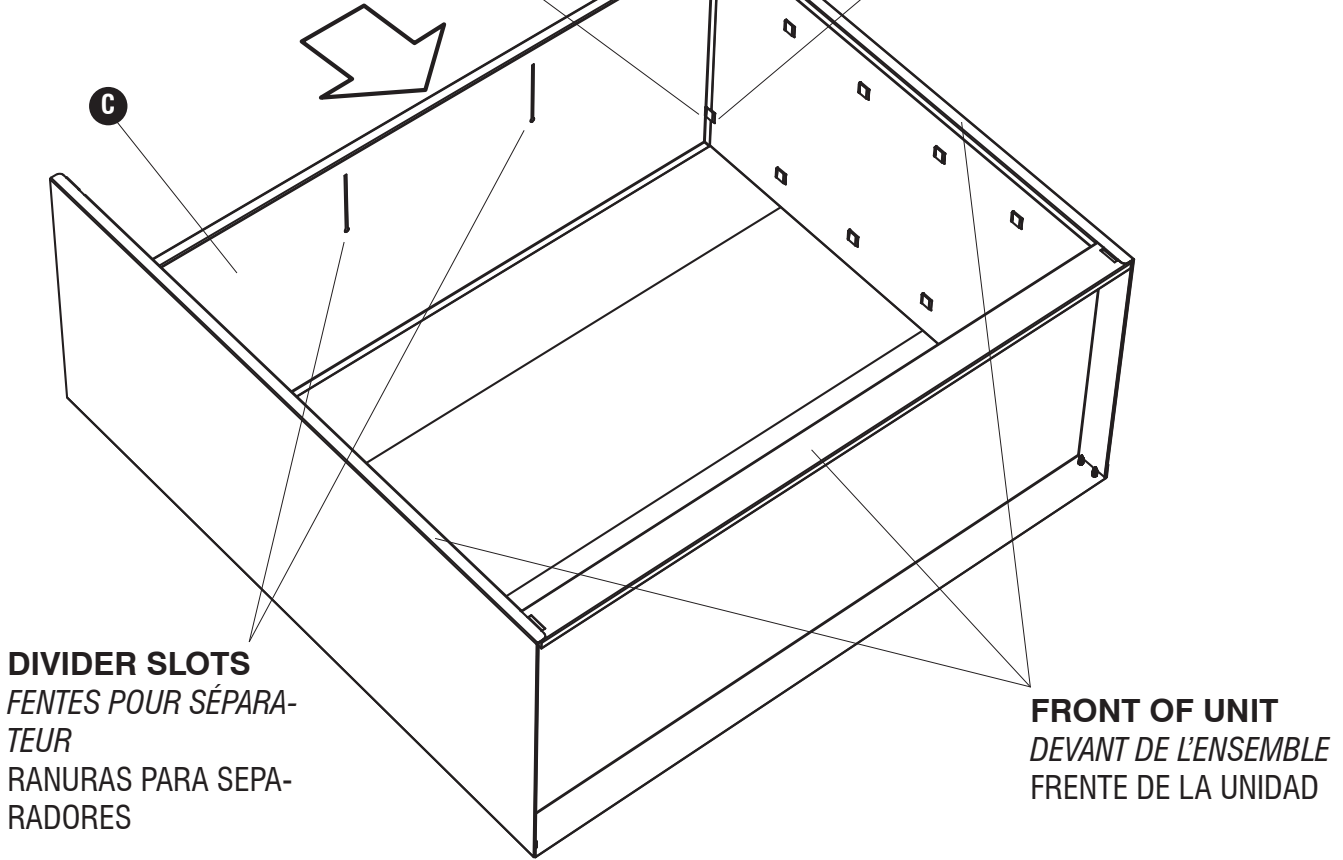

5

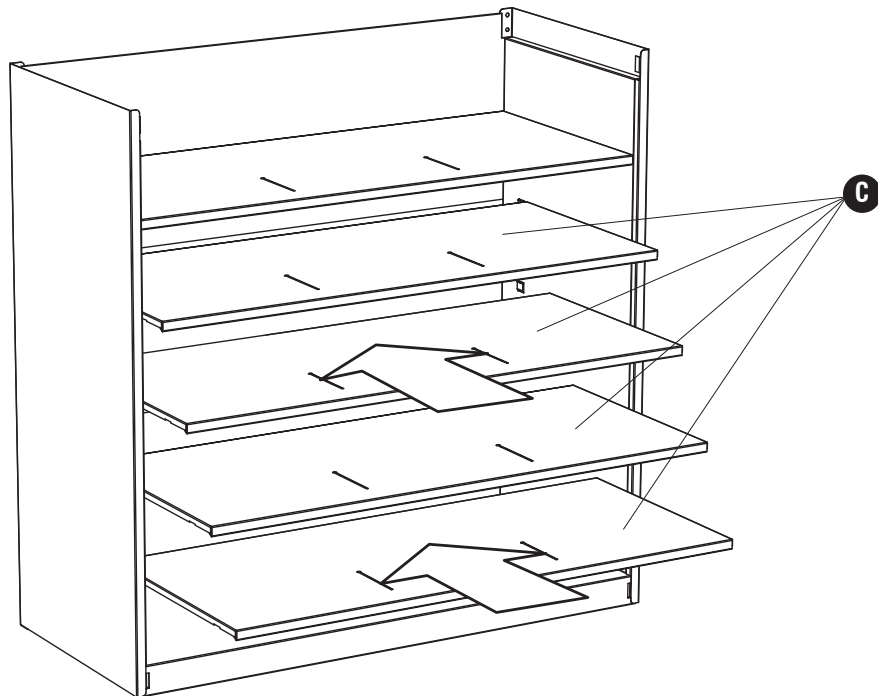

6

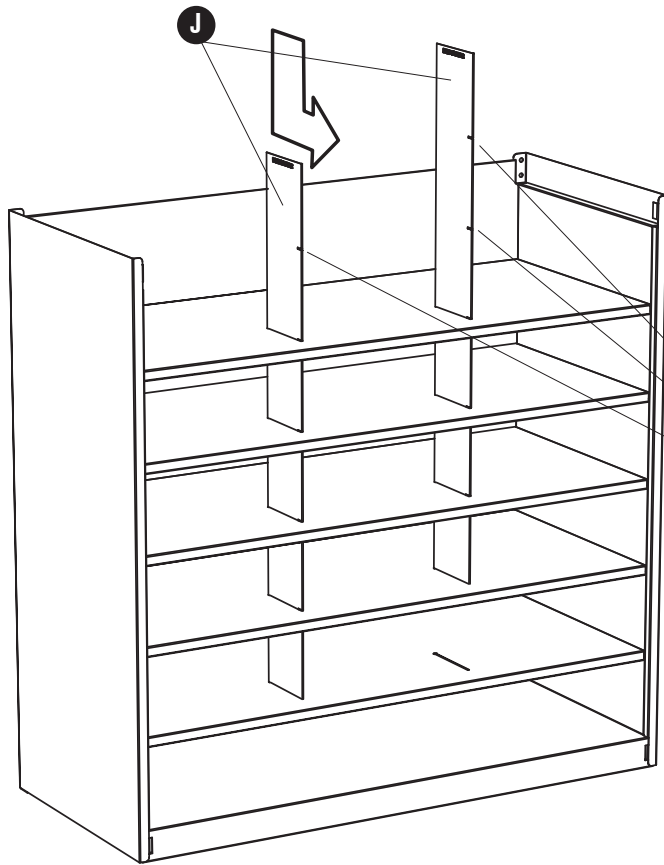

IMPORTANT: STAMPED PART NUMBER GOES AT TOP OF UNIT
ATTENTION : S'ASSURER QUE LE NUMÉRO DE PIÈCE IMPRIMÉ SE TROUVE VERS LE HAUT DE L'ENSEMBLE.
IMPORTANTE: EL NÚMERO DE PIEZA DEBE QUEDAR EN LA PARTE SUPERIOR DE LA UNIDAD.

LOCKING SLOTS
FENTES DE BLOPAGE
HENDIDURAS DE FIJACIÓN

7 **M**  (6)

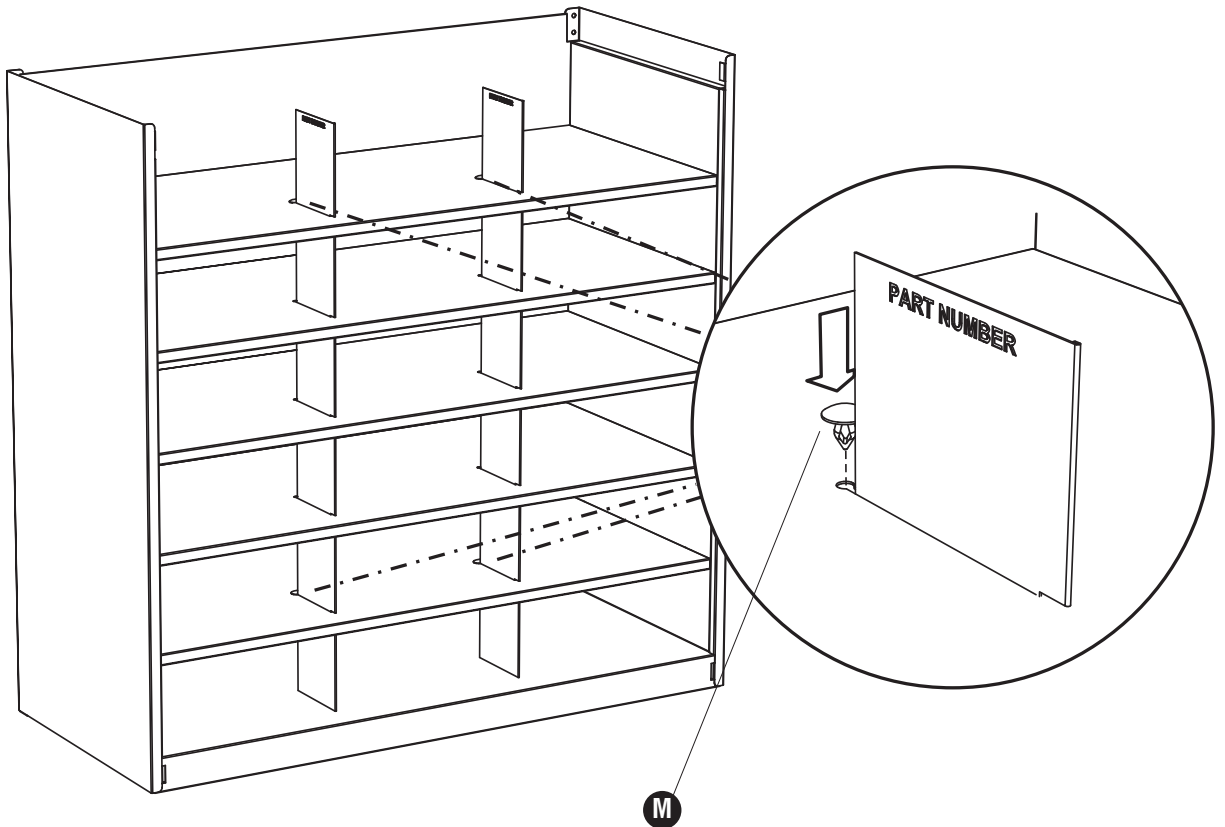

8

IMPORTANT: BACK PANEL GOES INSIDE SHELF

ATTENTION : S'ASSURER QUE LE PANNEAU DE FOND SE TROUVE À L'INTÉRIEUR DE L'TABLETTE.

IMPORTANTE: EL PANEL POSTERIOR DEBE QUEDAR EN EL INTERIOR DE LA REPISA.

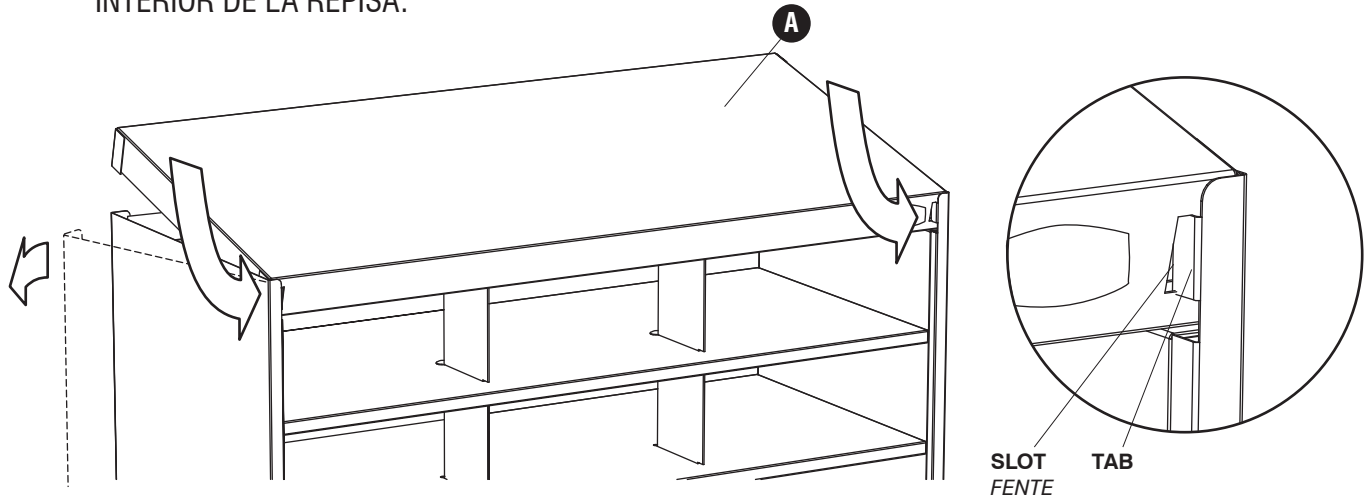

9 **N**  (4)

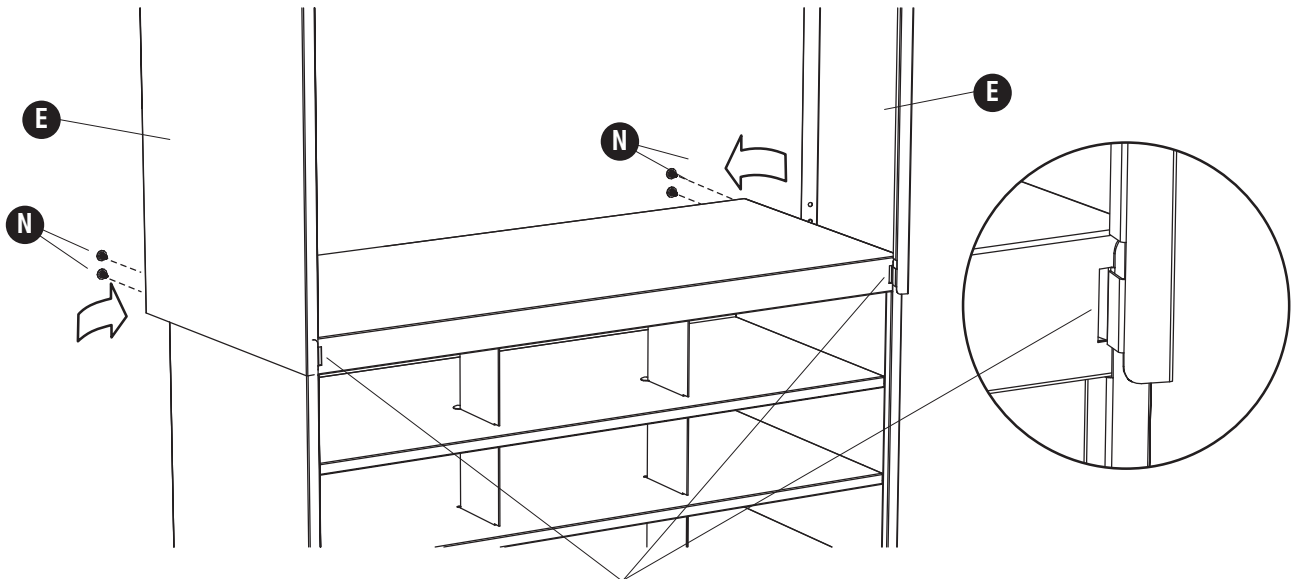

SAME SLOT USED BY LOWER PANEL

LA MÊME FENTE QU'UTILISE LE PANNEAU INFÉRIEUR

MISMA RANURA QUE SE UTILIZÓ PARA EL PANEL INFERIOR

NOTCH
ENTAILLE
HENDIDURA

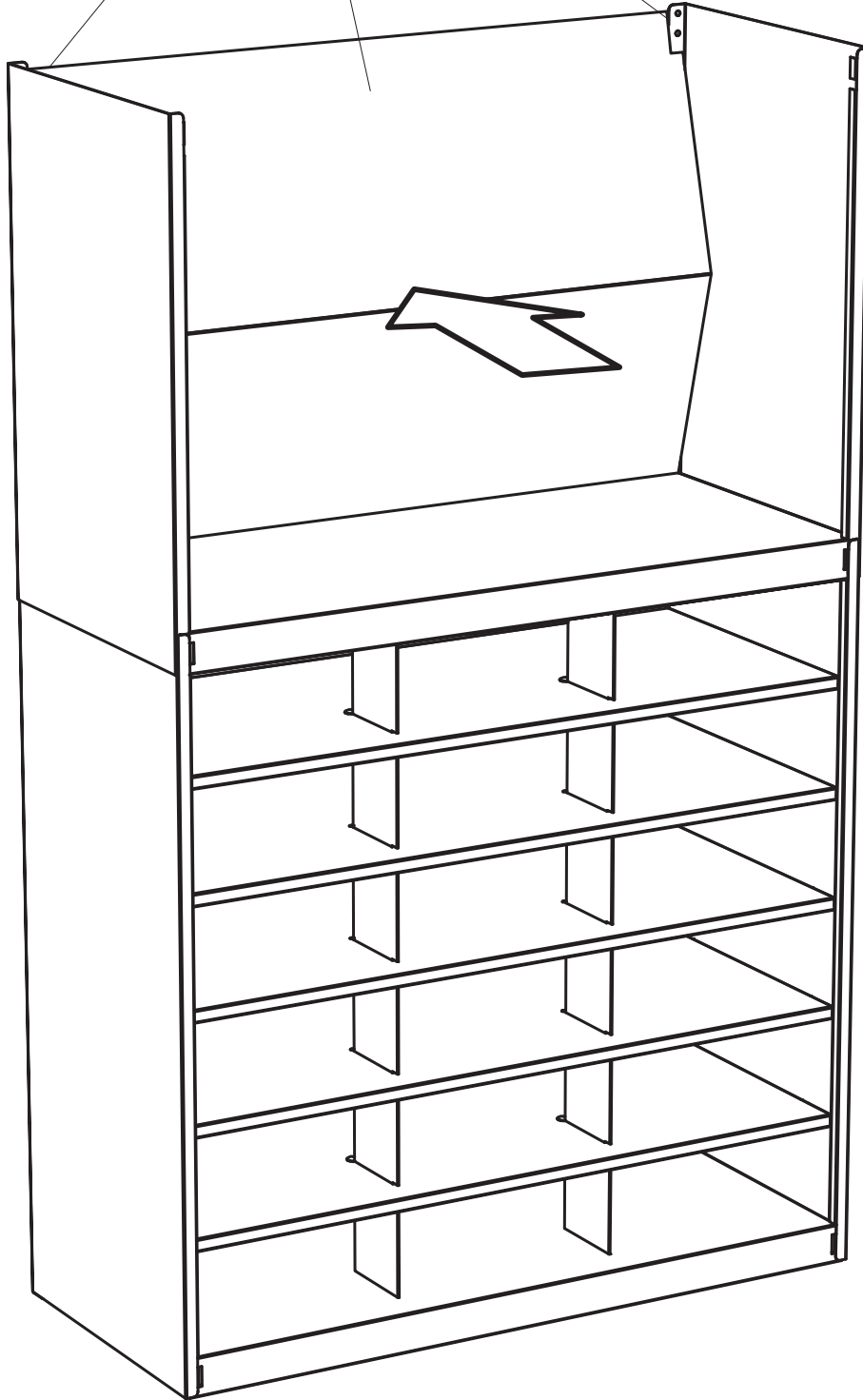

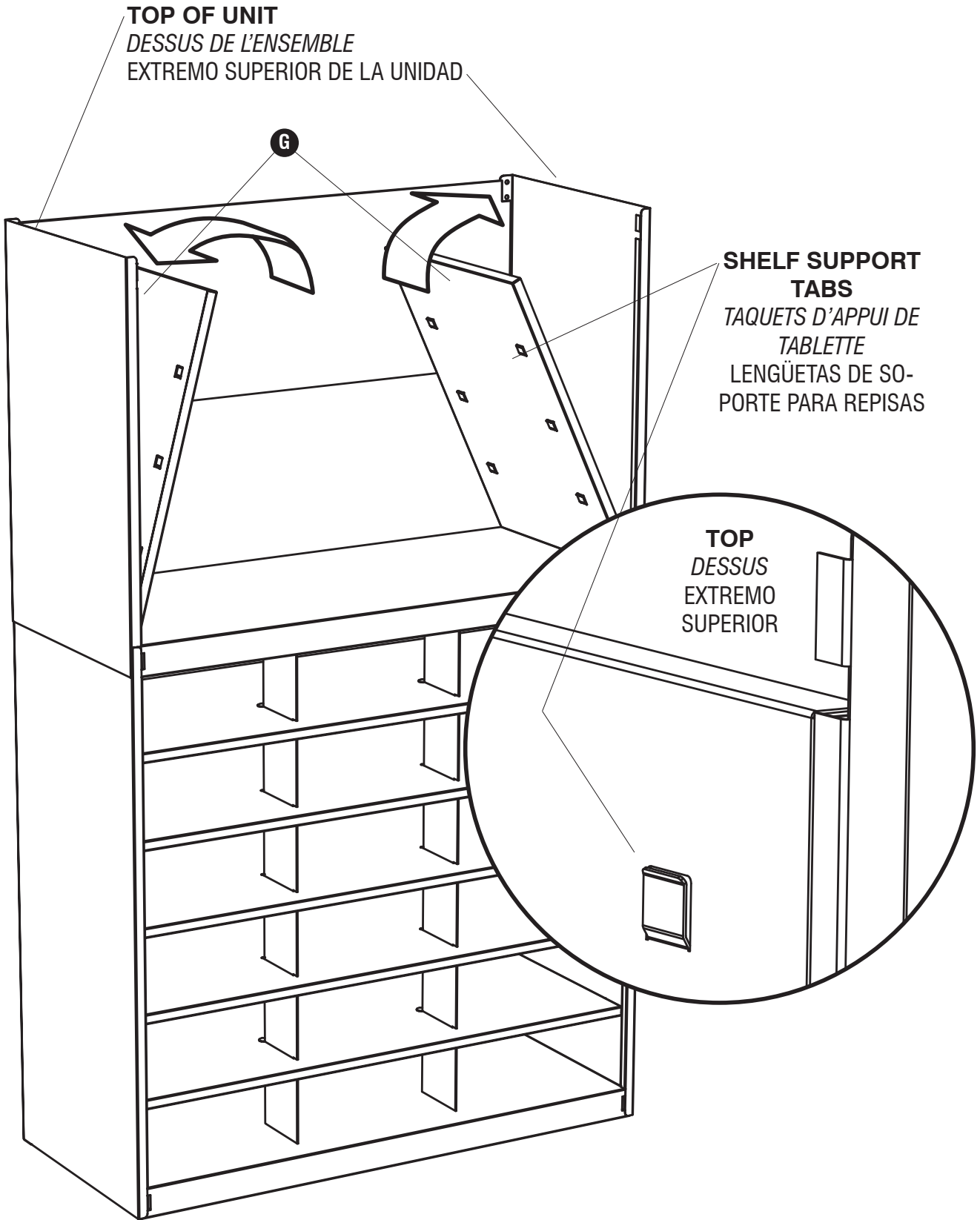

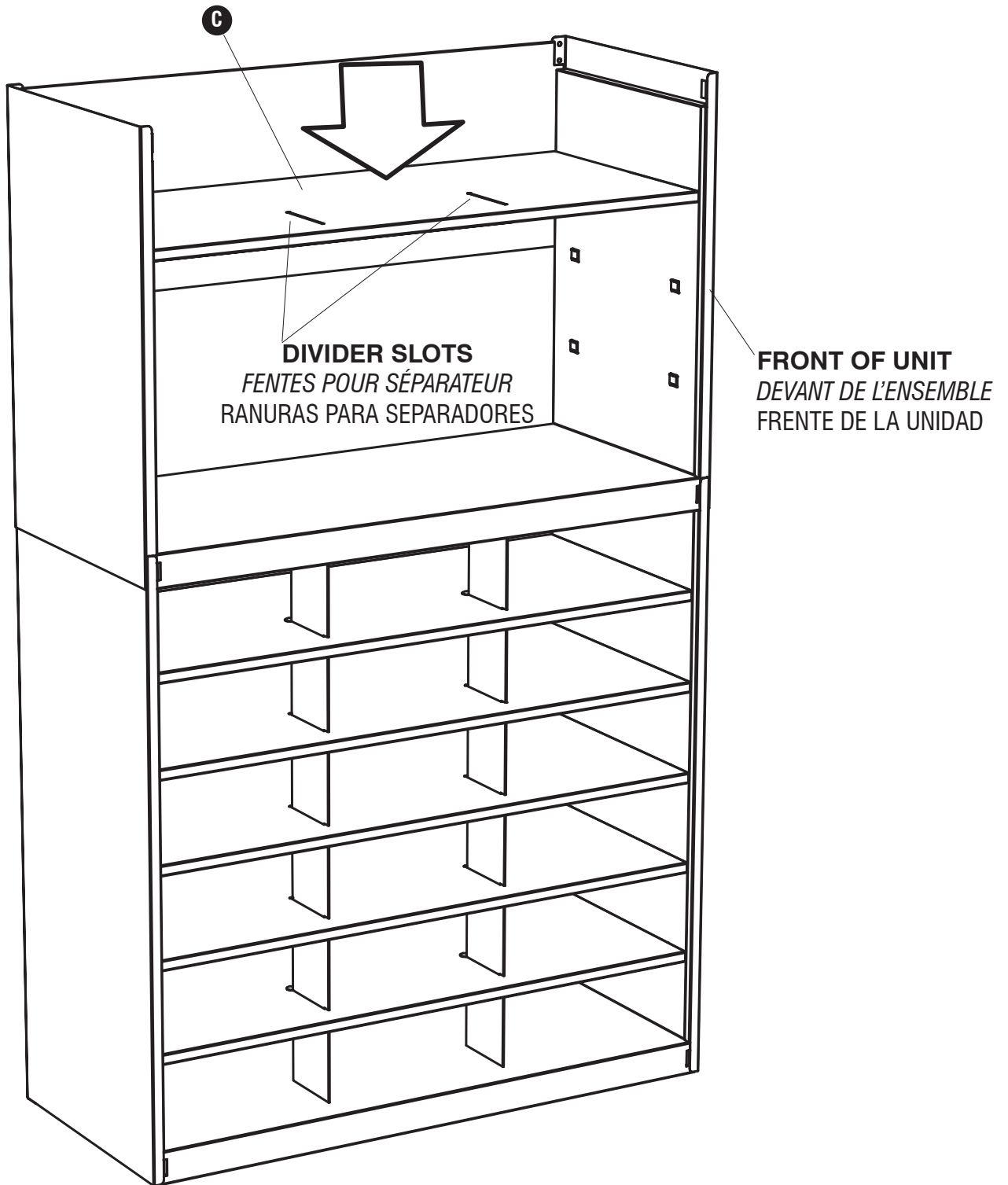

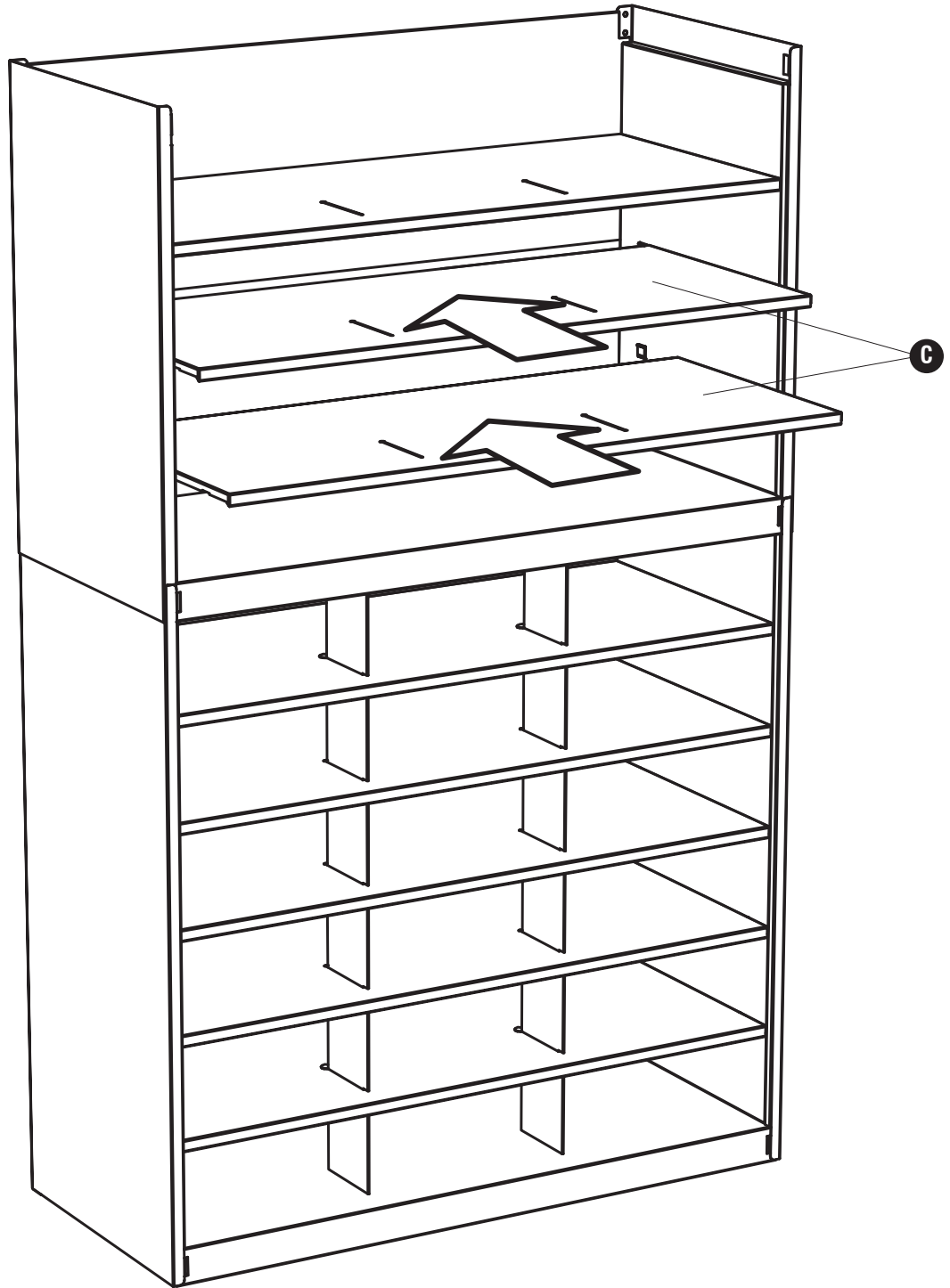

IMPORTANT: STAMPED PART NUMBER GOES AT TOP OF UNIT
ATTENTION : S'ASSURER QUE LE NUMÉRO DE PIÈCE IMPRIMÉ SE TROUVE VERS LE HAUT DE L'ENSEMBLE.
IMPORTANTE: EL NÚMERO DE PIEZA DEBE QUEDAR EN LA PARTE SUPERIOR DE LA UNIDAD.

LOCKING SLOTS
FENTES DE BLOCAGE
HENDIDURAS DE FIJACIÓN

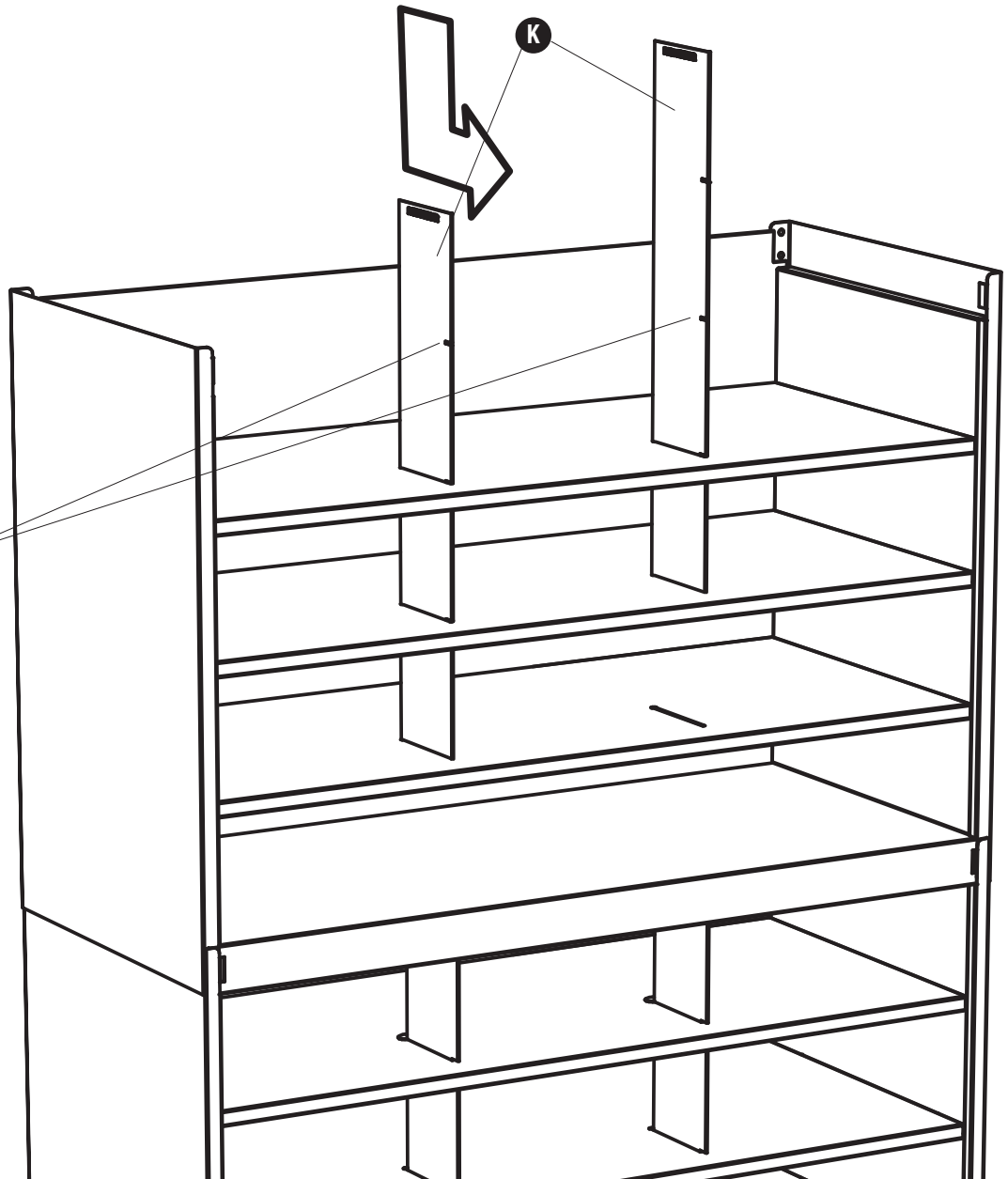

15 M (6)

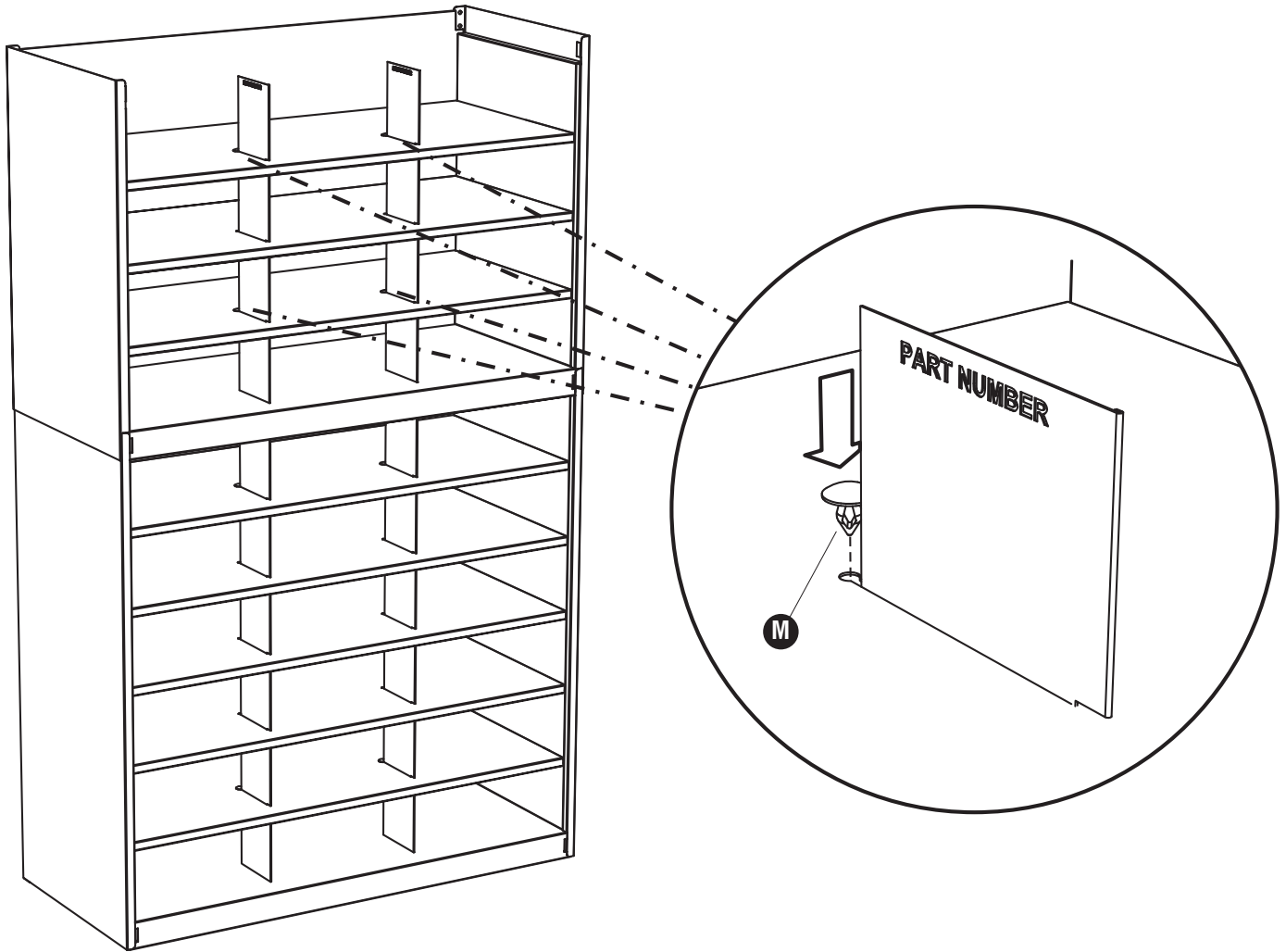

16 IMPORTANT: BACK PANEL GOES INSIDE SHELF

ATTENTION : S'ASSURER QUE LE PANNEAU DE FOND SE TROUVE À L'INTÉRIEUR DE L'TABLETTE.

IMPORTANTE: EL PANEL POSTERIOR DEBE QUEDAR EN EL INTERIOR DE LA REPISA.

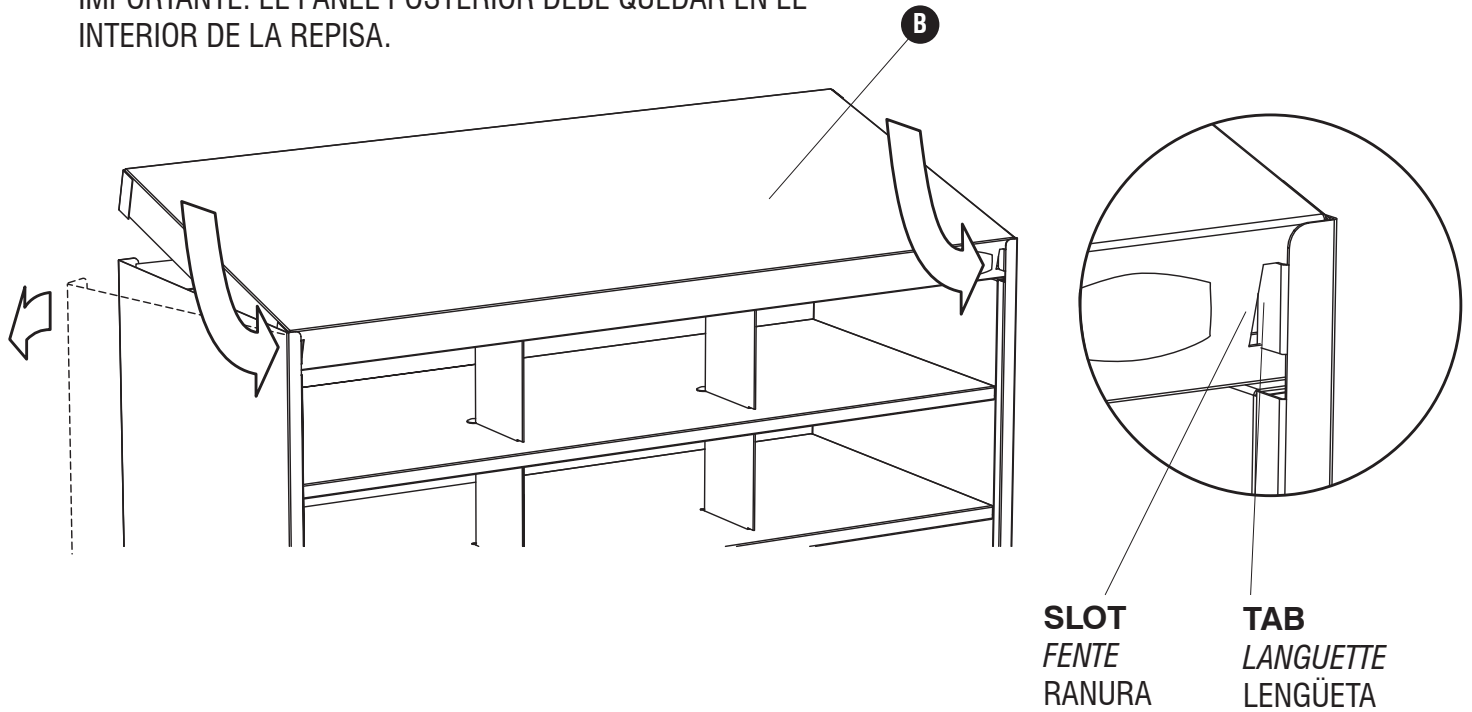

17 N (4)

O (2)

