

ASSEMBLY INSTRUCTIONS
INSTRUCTIONS DE MONTAGE
INSTRUCCIONES DE ENSAMBLAJE

9440

Après™ Open Bookcase
Après™ Ouvert Bibliothèque
Après™ Estanteria Abierta

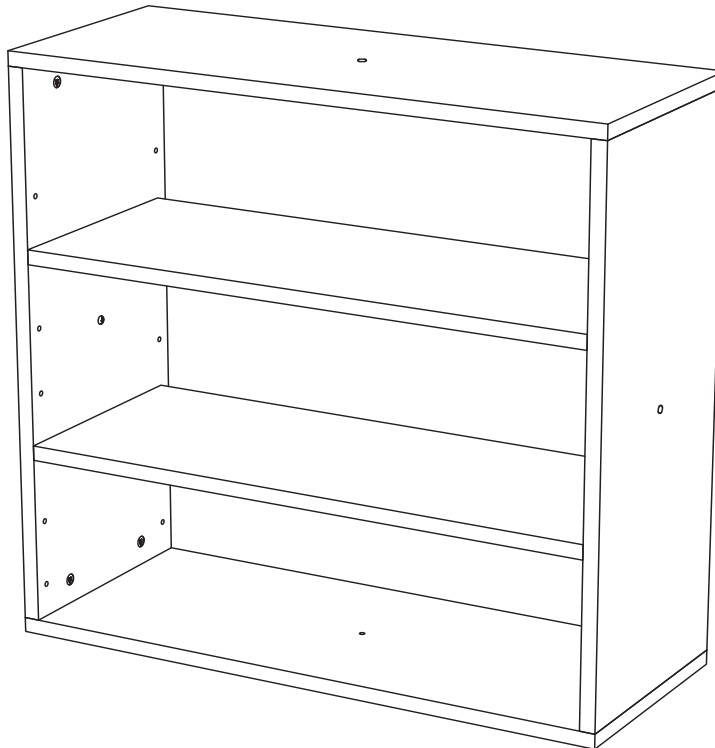

PRODUCT WARRANTY REGISTRATION is available online at: www.safcoproducts.com

• L'INSCRIPTION POUR LA GARANTIE DU PRODUIT est disponible sur l'Internet : www.safcoproducts.com

• EI REGISTRO PARA LA GARANTÍA DEL PRODUCTO está disponible en la Internet: www.safcoproducts.com

For questions or concerns, please call **1-800-664-0042**
available Monday-Friday 7:00 AM to 6:00 PM (Central Time) (English-speaking operators)

Si vous avez des questions pour poser ou les préoccupations pour exprimer, connecter **au 1-800-664-0042** de 7H00 à 18H00 (Heure centrale) (Opérateurs de langue anglaise)

Si usted tiene preguntas o preocupaciones, por favor llame **1-800-664-0042** de 7:00 AM a 6:00 PM (Hora Central) (Operadores que hablan inglés)

TOOLS REQUIRED: Flat-bladed Screwdriver; Phillips Screwdriver;
Hammer; Tape measure

PARTS LIST

CODE	DESCRIPTION	QTY	PART NO.
(A)	Top panel	2	9442-01§
(B)	Side panel	2	9444-06§
(C)	Shelf	2	9440-
(D)			

§Note: When corresponding about parts, be sure to state color: Mahogany (MH), or Cherry (CY).

OUTILS REQUIS : Tournevis plat à lame ; tournevis à pointe cruciforme ; marteau; Mètre à ruban

LISTE DES PIÈCES

CODE	DESCRIPTION	QUANTITÉ	N° DE PIÈCE
(A)	Panneau supérieur	2	9442-01§
(B)	Panneau côté	2	9444-06§
(C)	Étagère	2	9440-03§
(D)	Panneau arrière	1	9445-09§

§ Noter: Quand correspondre au sujet de parties, soyez sûr d'affirmer la couleur: Acajou (MH) ou Cerise









HERRAMIENTAS REQUERIDAS: Piso aspas destornillador; destornillador Phillips; martillo; Cinta métrica

LISTA DE PIEZAS









CODIGO	DESCRIPCIÓN	CANTIDAD	NO. DE PIEZA
(A)	Panel superior	2	9442-01§
(B)	Panel superior	2	9444-06§
(C)	Estante	2	9440-03§
(D)	Panel trasero	1	9445-09§

§ Note: Al corresponder sobre las piezas, esté seguro declarar el color: Caoba (MH) o Cereza



HARDWARE PACK 9440-19§

 E Locking Cam Qty.: 8 #HFFMFC	 F Screw Post Qty.: 8 #HFFMFB
 G Shelf Peg Qty.: 8 #HSFBNZ	 H Nail Qty.: 20 #FNAIL
 I Female Connector Screw Qty.: 2 #5340-28NC	 J Male Connector Screw Qty.: 2 #5340-29NC
 K Wood Dowel Qty.: 8 #H8MMDWL	 L Wood Screw Hole Cover Qty.: 4 #9440-10§

Paquet matériel 9440-19§

 E Cam Qté.: 8 #HFFMFC	 F Poteau avec la fin d'un vis Qté.: 8 #HFFMFB
 G Épingle du glissement Qté.: 8 #HSFBNZ	 H Clous Qté.: 20 #FNAIL
 I Vis pour se relier (femelle) Qté.: 2 #5340-28NC	 J Vis pour se relier (mâle) Qté.: 2 #5340-29NC
 K Piquet de bois Qté.: 8 #H8MMDWL	 L pour la Couverture Trou Qté.: 4 #9440-10§

Paquete material 9440-19§

 E Leva del freno Cant.: 8 #HFFMFC	 F Poste con el tornillo-extremo Cant.: 8 #HFFMFB
 G Clavija del estante Cant.: 8 #HSFBNZ	 H Punta de Paris Cant.: 20 #FNAIL
 I Tornillo para conectar (hembra) Cant.: 2 #5340-28NC	 J Tornillo para conectar (varón) Cant.: 2 #5340-29NC
 K Clavijas de madera Cant.: 8 #H8MMDWL	 L madera para cubrir el agujero Cant.: 4 #9440-10§

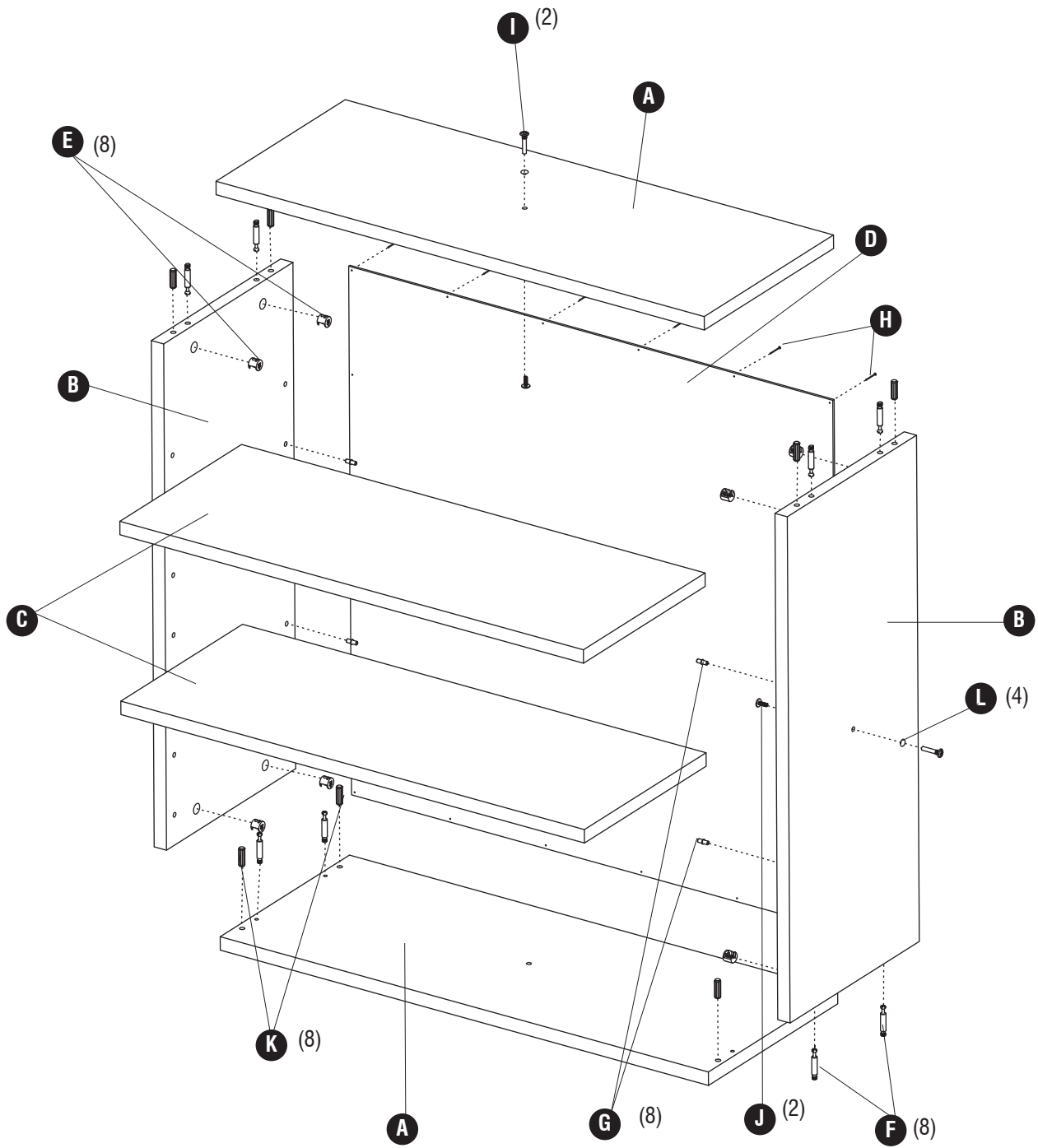

1

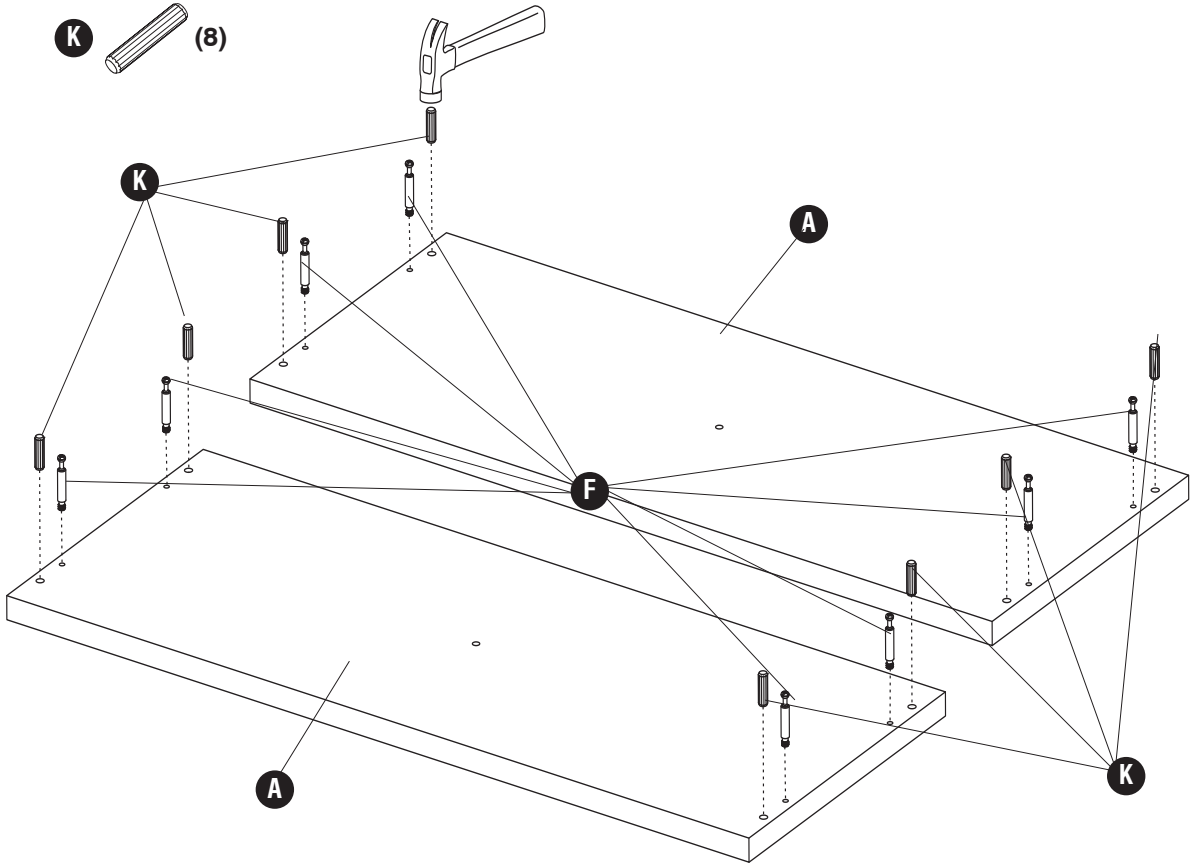

2

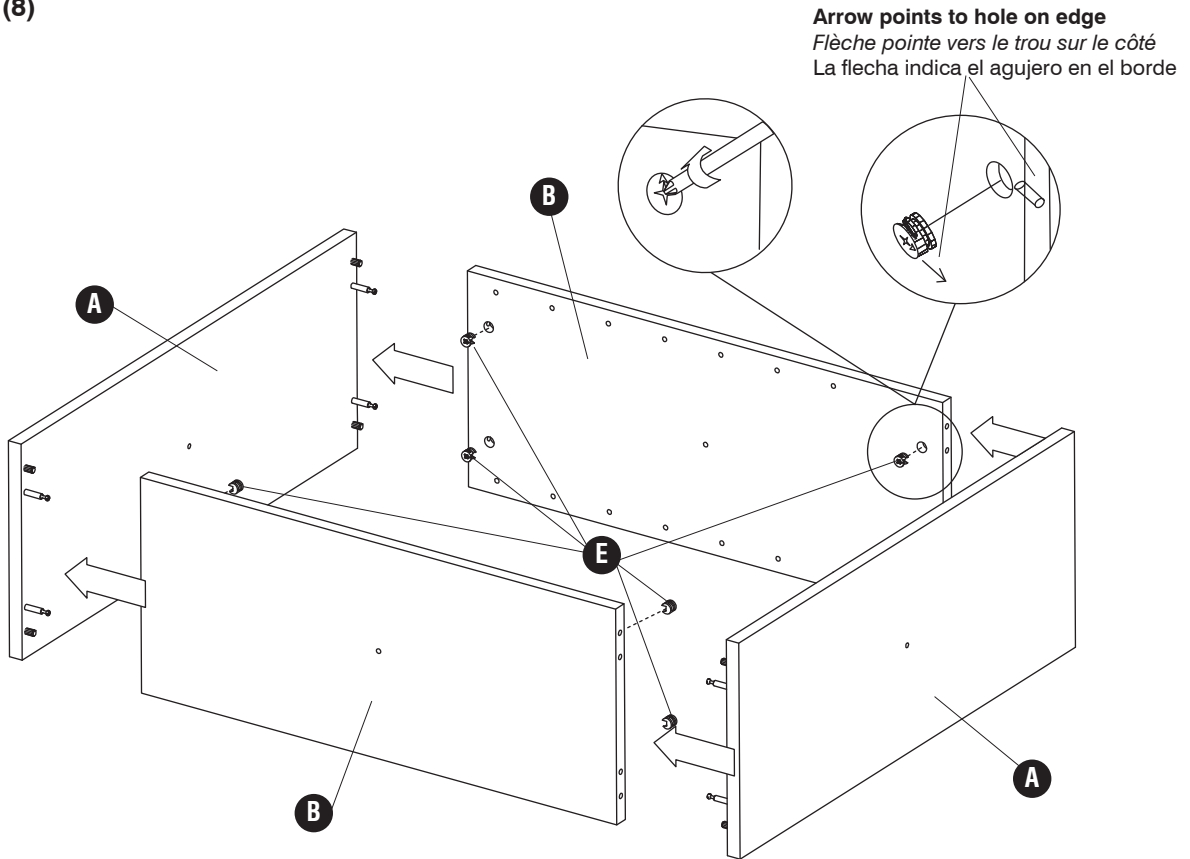

3 H (20)

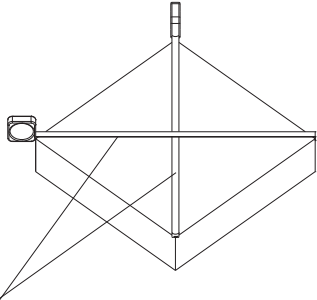
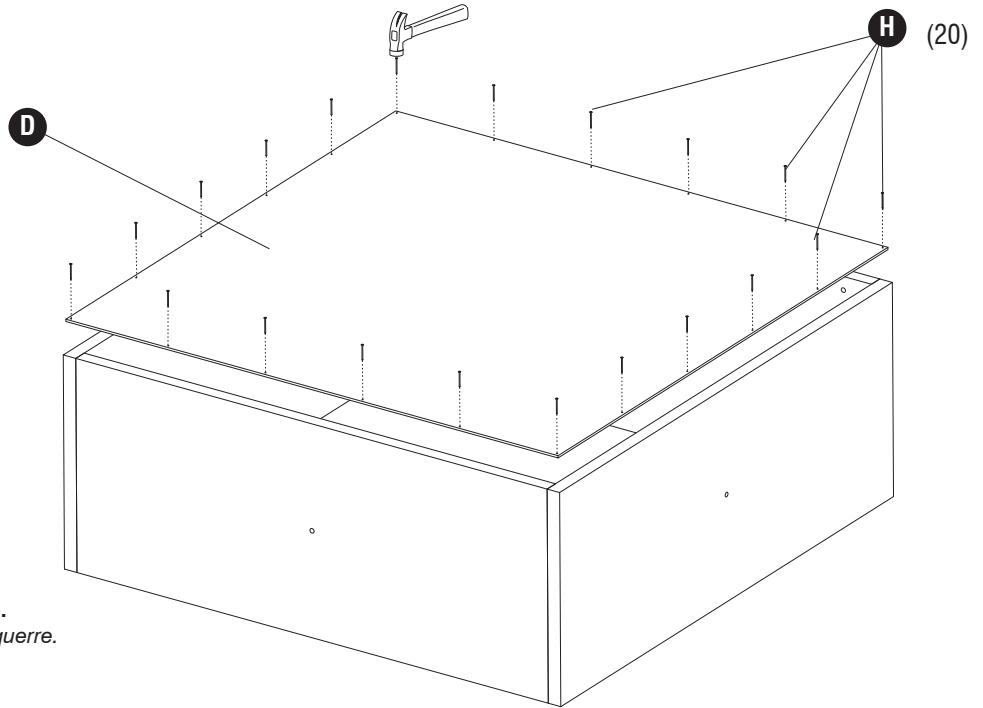
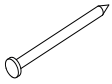

IMPORTANT: Must be equal to be square.
ATTENTION: Si l'égalité, puis l'unité est d'équerre.
IMPORTANTE: Debe ser igual al cuadrado.

4 G (8)

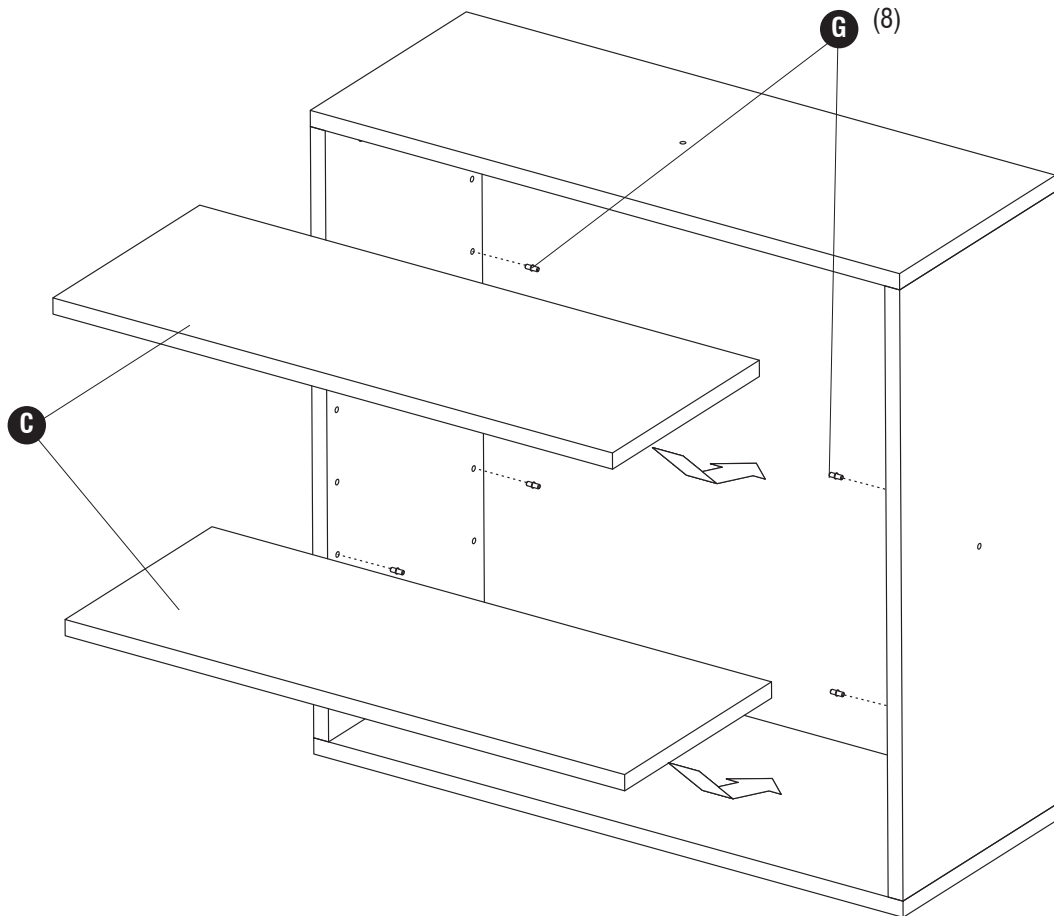

5 I (2) **J** (2) **L** (4)



Note: for connecting adjacent units only, use cap on exposed holes.

Noter: pour relier les unités adjacentes seulement, le utiliser couvercle sur exposé trou.

Note: para conectar unidades adyacentes solamente, uso madera tapon para cubrir el agujero