

ASSEMBLY INSTRUCTIONS
INSTRUCTIONS DE MONTAGE
INSTRUCCIONES DE ENSAMBLAJE

9445

**Après™ Shelf with Lower
File Drawer**

*Après™ Basse-dossier de tiroir
avec étagère*

**Après™ Cajón baja archivo con
estante**

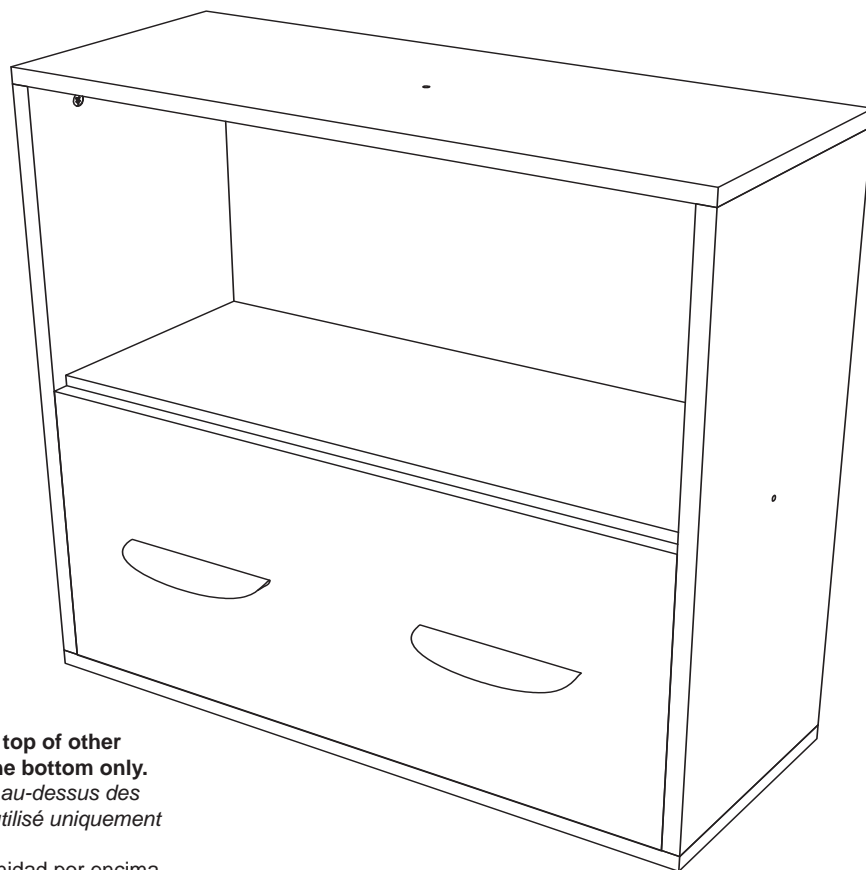

Warning: Do not stack this unit on top of other units. This unit must be used on the bottom only.

Attention: Ne pas empiler cette unité au-dessus des autres unités. Cet appareil doit être utilisé uniquement sur le fond.

Advertencia: No coloque para esta unidad por encima de las otras unidades. Esta unidad debe utilizarse sólo en la parte inferior.

PRODUCT WARRANTY REGISTRATION is available online at: www.safcoproducts.com

• L'INSCRIPTION POUR LA GARANTIE DU PRODUIT est disponible sur l'Internet : www.safcoproducts.com

• EI REGISTRO PARA LA GARANTÍA DEL PRODUCTO está disponible en la Internet: www.safcoproducts.com



















For questions or concerns, please call **1-800-664-0042**
available Monday-Friday 7:00 AM to 6:00 PM (Central Time) (English-speaking operators)

Si vous avez des questions pour poser ou les préoccupations pour exprimer, connecter **au 1-800-664-0042**
de 7H00 à 18H00 (Heure centrale) (Opérateurs de langue anglaise)

Si usted tiene preguntas o preocupaciones, por favor llame **1-800-664-0042**
de 7:00 AM a 6:00 PM (Hora Central) (Operadores que hablan inglés)

TOOLS REQUIRED: Flat-bladed Screwdriver; Phillips Screwdriver; Hammer; Tape measure
OUTILS REQUIS : *Tournevis plat à lame ; tournevis à pointe cruciforme ; marteau; Mètre à ruban*
HERRAMIENTAS REQUERIDAS: Piso aspas destornillador; destornillador Phillips; martillo; Cinta métrica

PARTS LIST / LISTE DES PIÈCES / LISTA DE PIEZAS			
CODE / CÓDIGO	DESCRIPTION / DESCRIPTION / DESCRIPCIÓN	QTY / QUANTITÉ / CANTIDAD	PART NO. / N° DE PIÈCE / NO. DE PIEZA
(A)	Top Panel / Panneau supérieur / Panel superior	2	9442-01\$
(B)	Left Side Panel / Panneau côté gauche / Panel lateral izquierdo	1	9445-02\$
(C)	Right Side Panel / Panneau côté droit/ Panel lateral derecho	1	9445-12\$
(D)	Shelf / Étagère / Estante	1	9445-03\$
(E)	Back Panel / Panneau arrière / Panel trasero	1	9445-09\$
(F)	Drawer Right Side/ Tiroir côté droit/ Cajón lateral derecho	1	9445-05GR
(G)	Drawer Left Side /Tiroir côté gauche / Cajón lateral izquierdo	1	9445-06GR
(H)	Drawer Back / Tiroir arrière / Cajón del fondo	1	9445-07GR
(I)	Drawer Bottom/ Tiroir inférieur/ Cajón inferior	1	9445-08GR
(J)	Drawer Front /Tiroir devant / Parte delantera del cajón	1	9445-13\$
(K)	Left Drawer Rail / Tiroir Rail gauche/Reil cajón izquierdo	1	9445-11NC
(L)	Right Drawer Rail /Tiroir Rail droit/ Riel cajón derecho	1	9445-10NC
(M)	File Hanger/Chemise Cintre/ Parcha Carpeta	4	9445-27NC

HARDWARE PACK / PAQUET MATÉRIEL / PAQUETE MATERIAL 9445-19\$			
N  Locking Cam <i>Came</i> Leva del freno Qty. / Qte. / Cant.: 12 #HFFMFC	O  Screw Post <i>Poteau avec la fin d'un vis</i> Poste con el tornillo extremo Qty. / Qte. / Cant.: 12 #HFFMFB	P  Nail <i>Clous</i> puntas de Paris Qty. / Qte. / Cant.: 20 #FNAIL	Q  Female Connector Screw <i>Vis pour se relier (femelle)</i> Tornillo para conectar (hembra) Qty. / Qte. / Cant.: 1 #5340-28NC
R  Male Connector Screw <i>Vis pour se relier (mâle)</i> Tornillo para conectar (varón) Qty. / Qte. / Cant.: 1 #5340-29NC	S  Wood Dowel <i>Piquet de bois</i> Clavijas de madera Qty. / Qte. / Cant.: 12 #H8MMDWL	T  Wood Screw Hole Cover <i>Bois pour la Couverture Trou</i> madera para cubrir el agujero Qty. / Qte. / Cant.: 4 #9440-10\$	U  Handle <i>Poignée</i> Manche Qty. / Qte. / Cant.: 2 #8962-31
V  Screw <i>Vis</i> Tornillo Qty. / Qte. / Cant.: 4 #9445-29NC	W  Connector pin <i>Goupille du connecte</i> Conector clavija Qty. / Qte. / Cant.: 2 #9444-02NC	X  Drawer Screw <i>Tiroir vis</i> Tornillo cajón, Qty. / Qte. / Cant.: 28 #3695-28	Y  Drawer Side Mount A <i>Tiroir côté monter A</i> lado montar cajón A Qty. / Qte. / Cant.: 2 #9445-23NC
Z  Drawer Side Mount B <i>Tiroir côté monter B</i> lado montar cajón B Qty. / Qte. / Cant.: 2 #9445-24NC	AA  Side Mount Screw <i>côté monter vis</i> lado montar tornillo Qty. / Qte. / Cant.: 2 #9445-22NC	BB  Hanger Clip <i>cintre connecteur</i> percha conector Qty. / Qte. / Cant.: 8 #9445-25NC	CC  Drawer Screw, large <i>Tiroir vis, grand</i> Tornillo cajón grande Qty. / Qte. / Cant.: 6 #8925-26
DD  "L" Brackets <i>"L" Supports</i> "L" Soportes Qty. / Qte. / Cant.: 2 #3680-15	EE  Rail Screw <i>Rail vis</i> Tornillo reil Qty. / Qte. / Cant.: 6 #9445-28NC		

§Note: When corresponding about parts, be sure to state color: Mahogany (MH), or Cherry (CY).

§ *Noter: Quand correspondre au sujet de parties, soyez sûr d'affirmer la couleur: Acajou (MH) ou Cerise (CY).*

§ Note: Al corresponder sobre las piezas, esté seguro de declarar el color: Caoba (MH) o Cereza (CY).

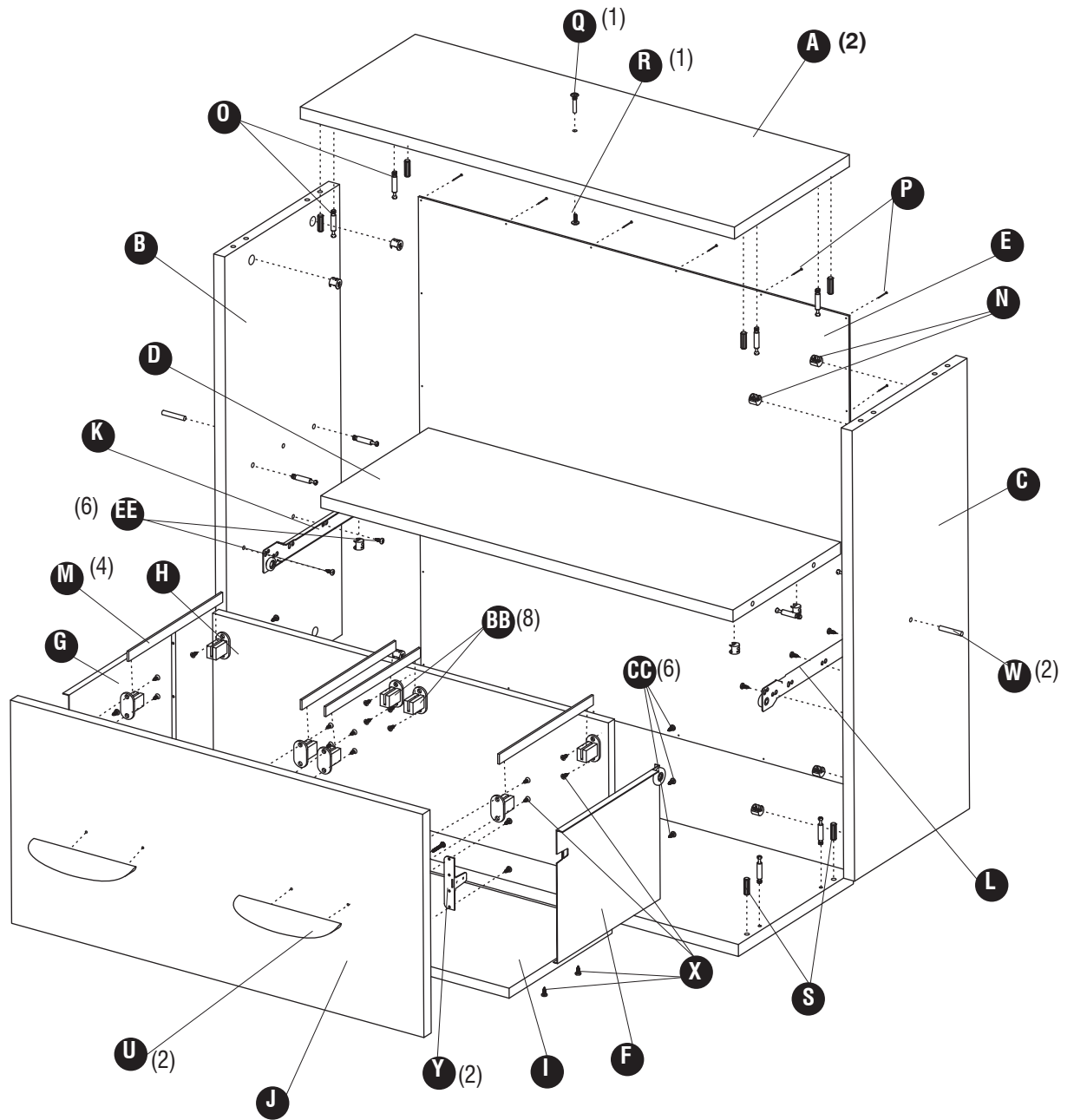

1

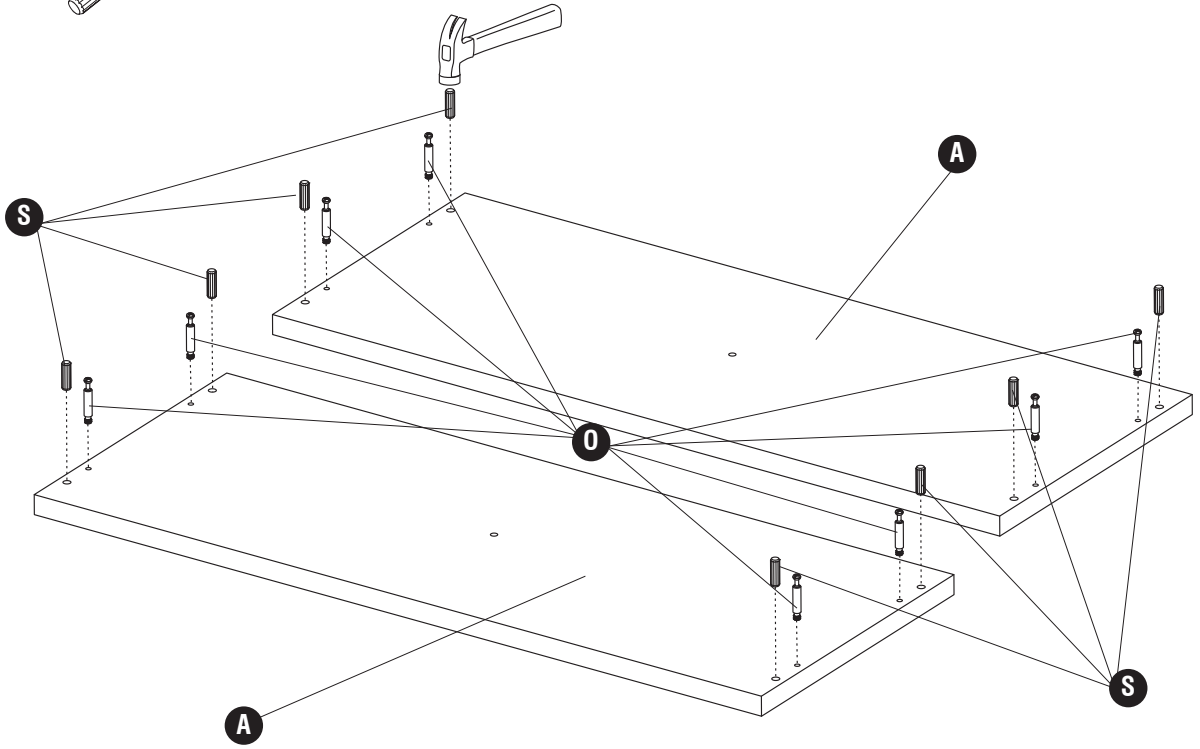
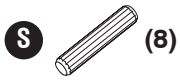
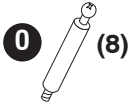

2

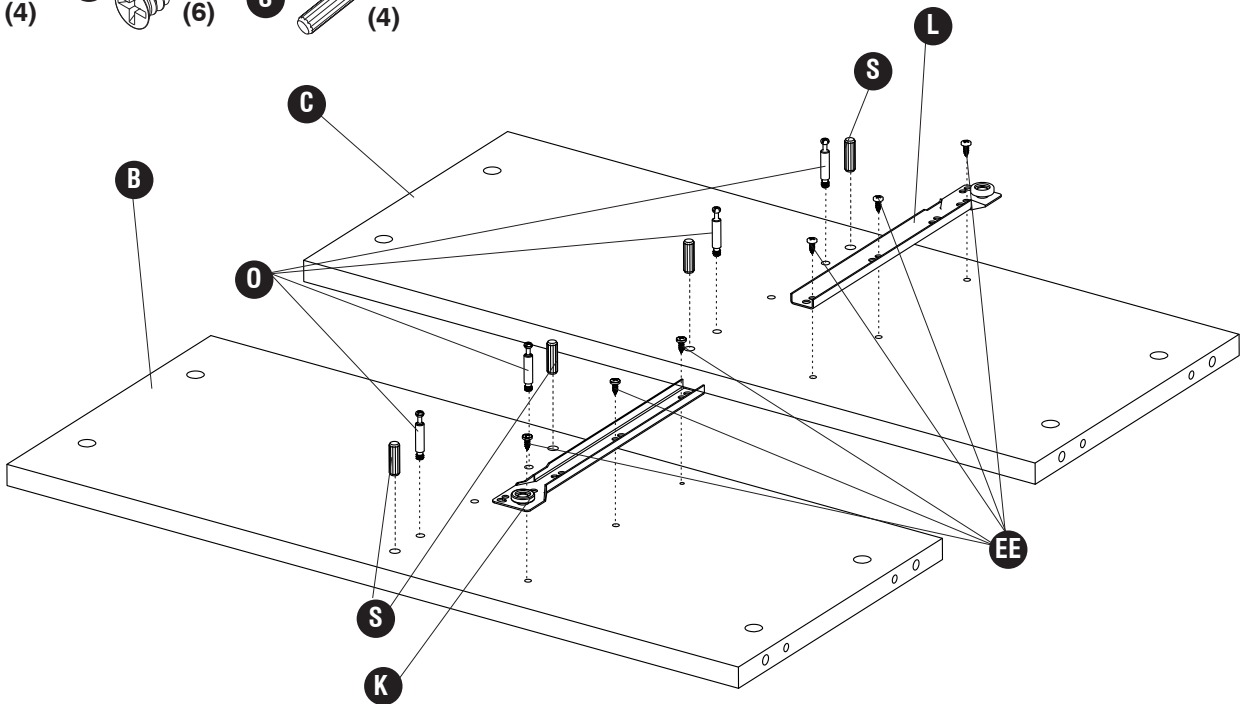
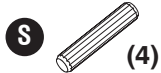
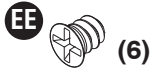
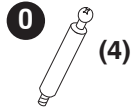

3 **N**  (4)

Arrow points to hole on edge
Flèche pointe vers le trou sur le côté
La flecha indica el agujero en el borde

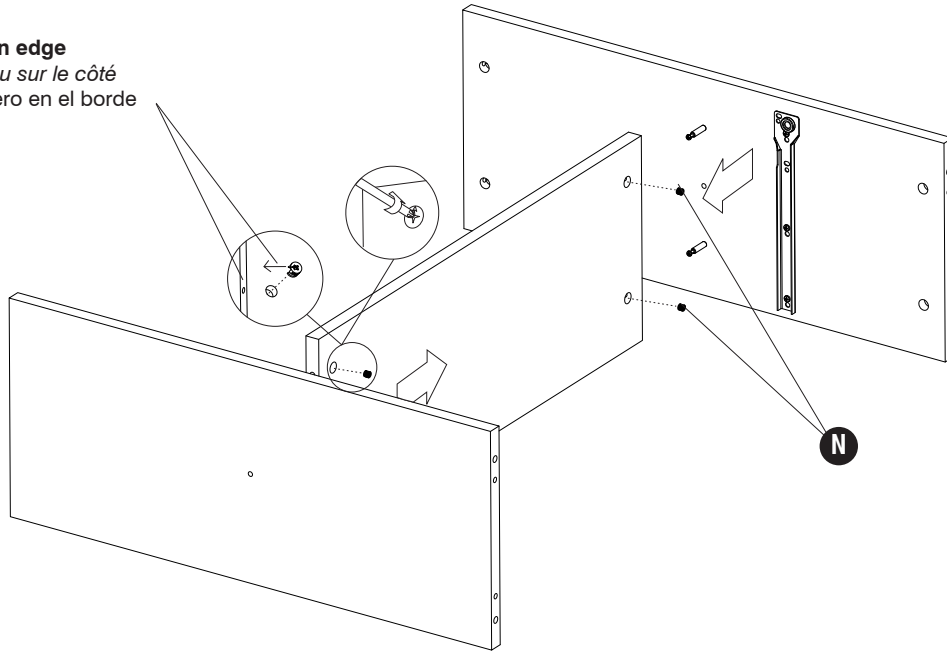

4 **N**  (8)

Arrow points to hole on edge
Flèche pointe vers le trou sur le côté
La flecha indica el agujero en el borde

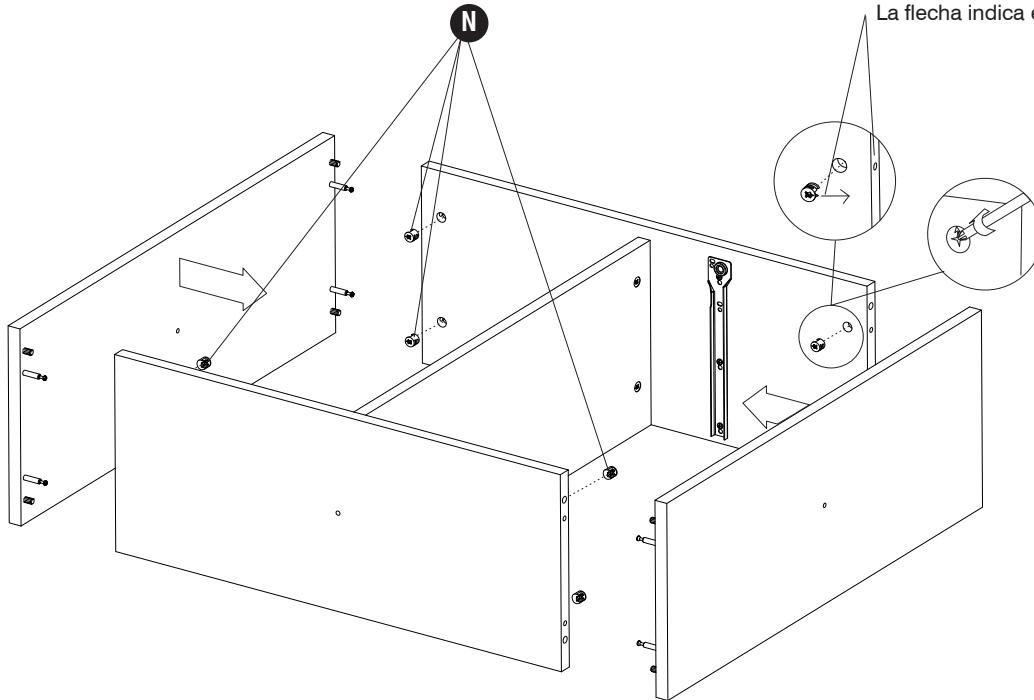

5 P (20)

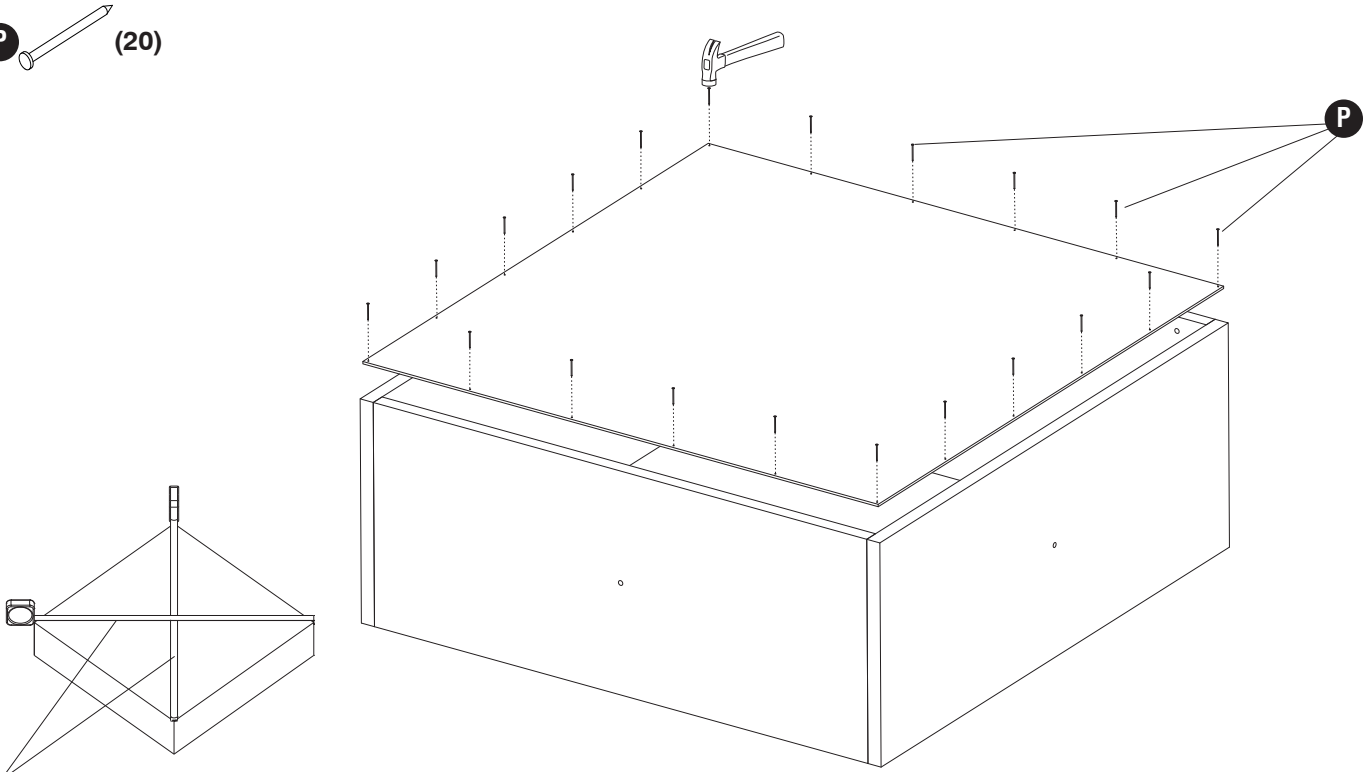

IMPORTANT: Must be equal to be square.
ATTENTION: Si l'égalité, puis l'unité est d'équerre.
IMPORTANTE: Debe ser igual al cuadrado.

6 Y (2) X (22) BB (8) DD (2)

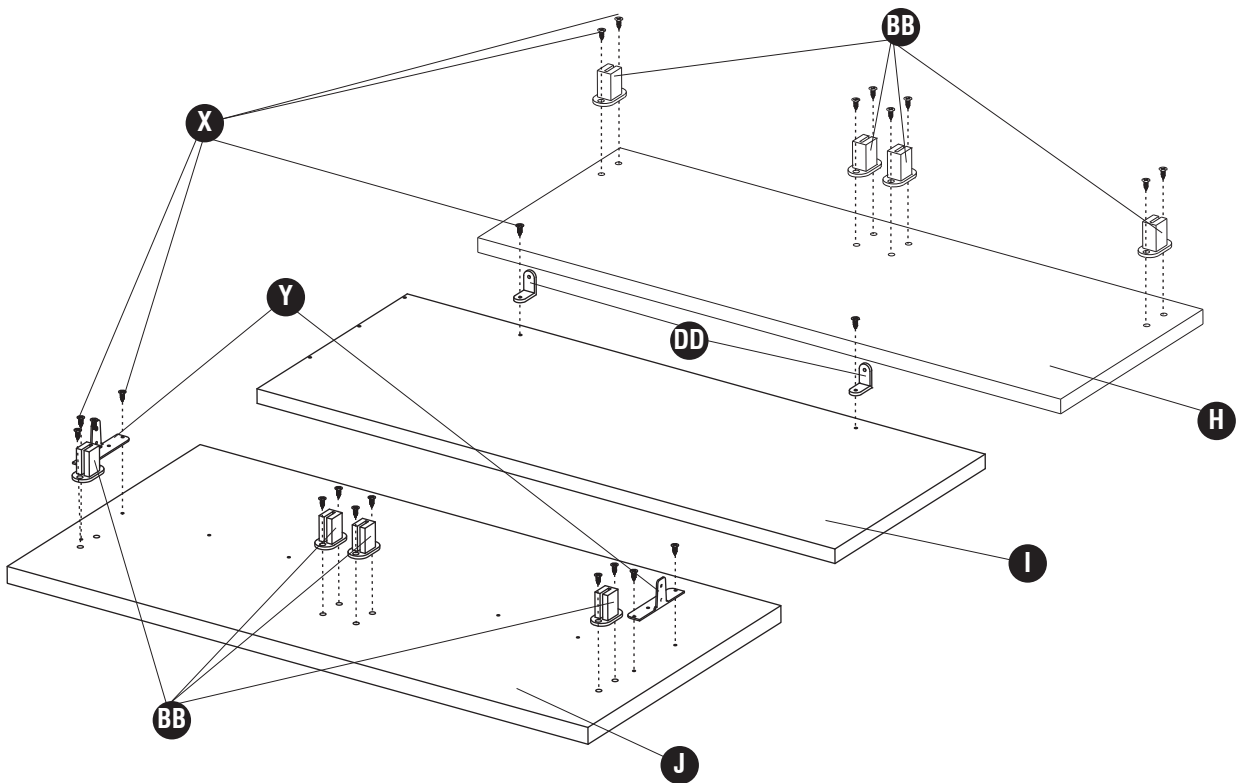

7 X  (4)

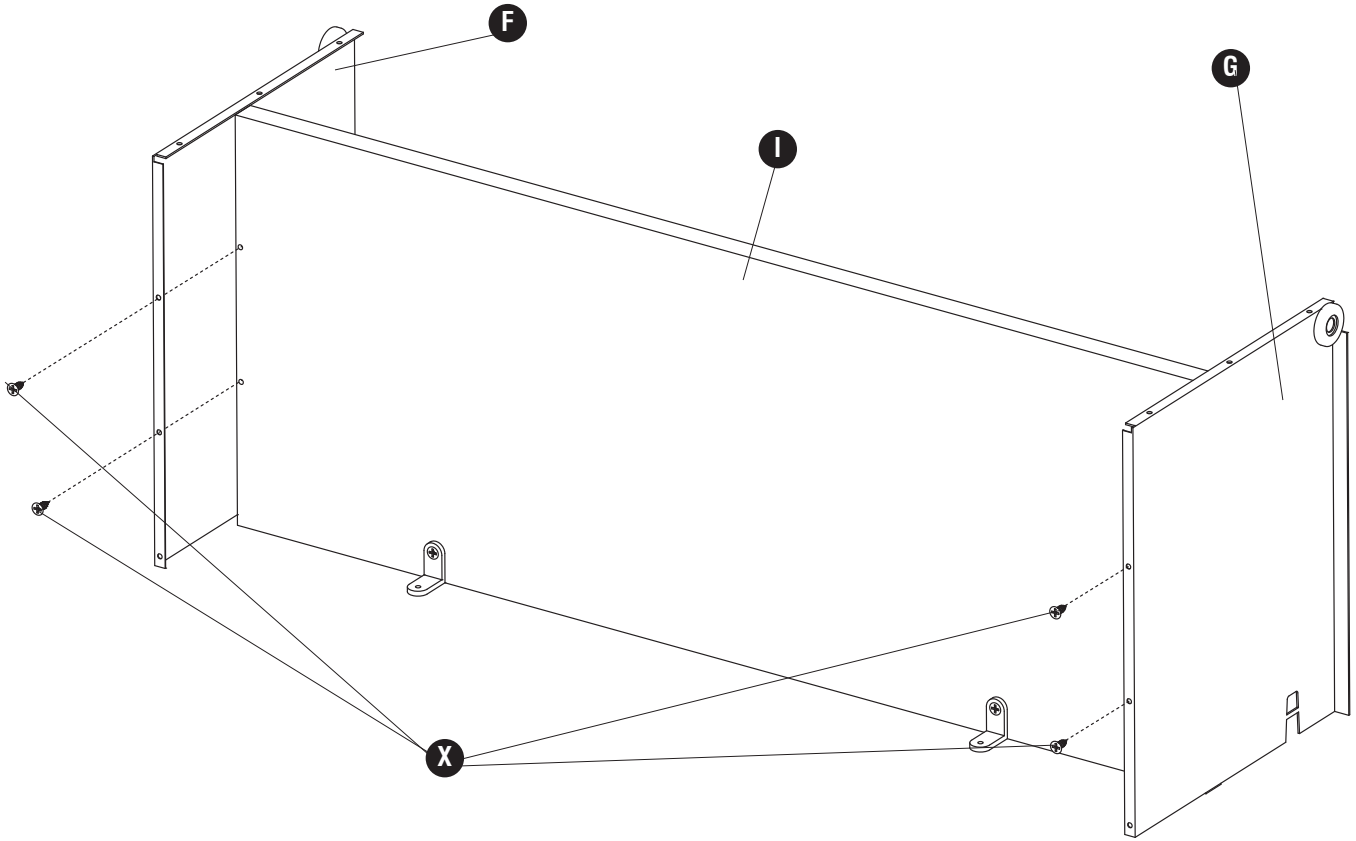

8 CC  (6)

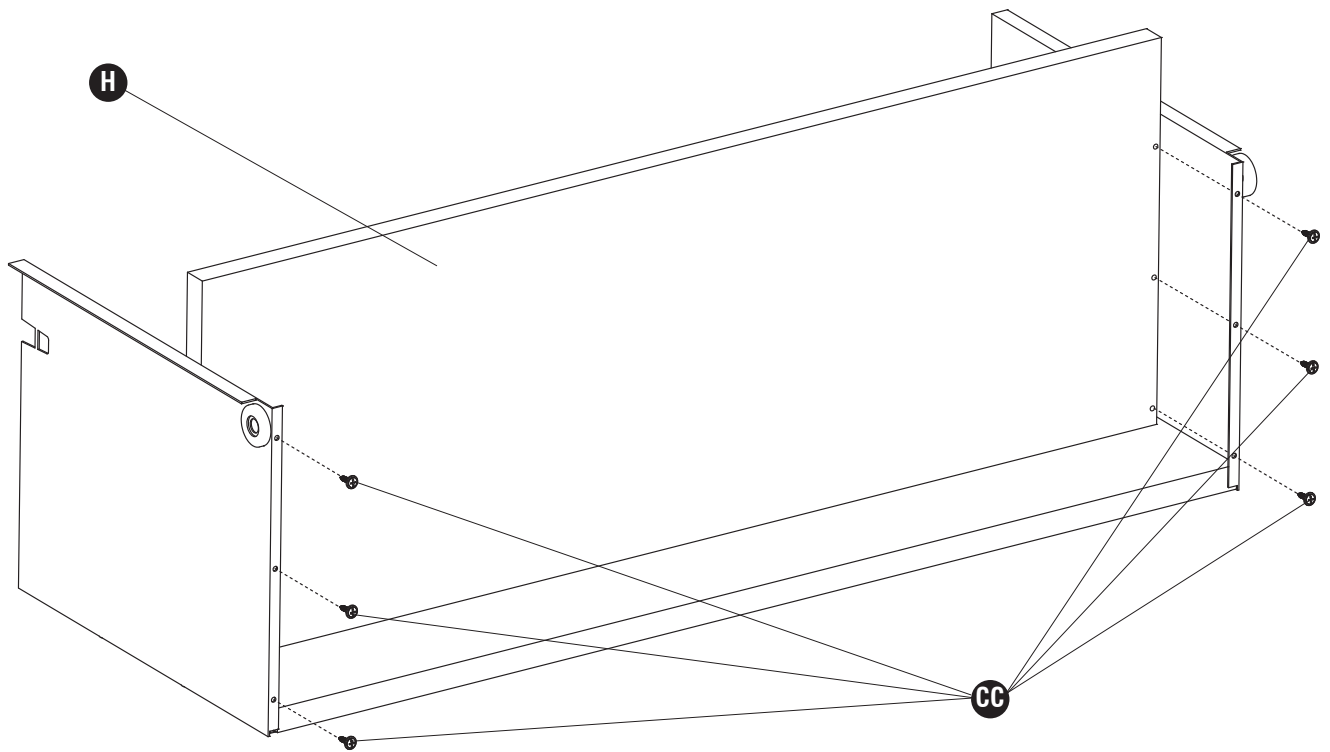

9 Z (2) AA (2)

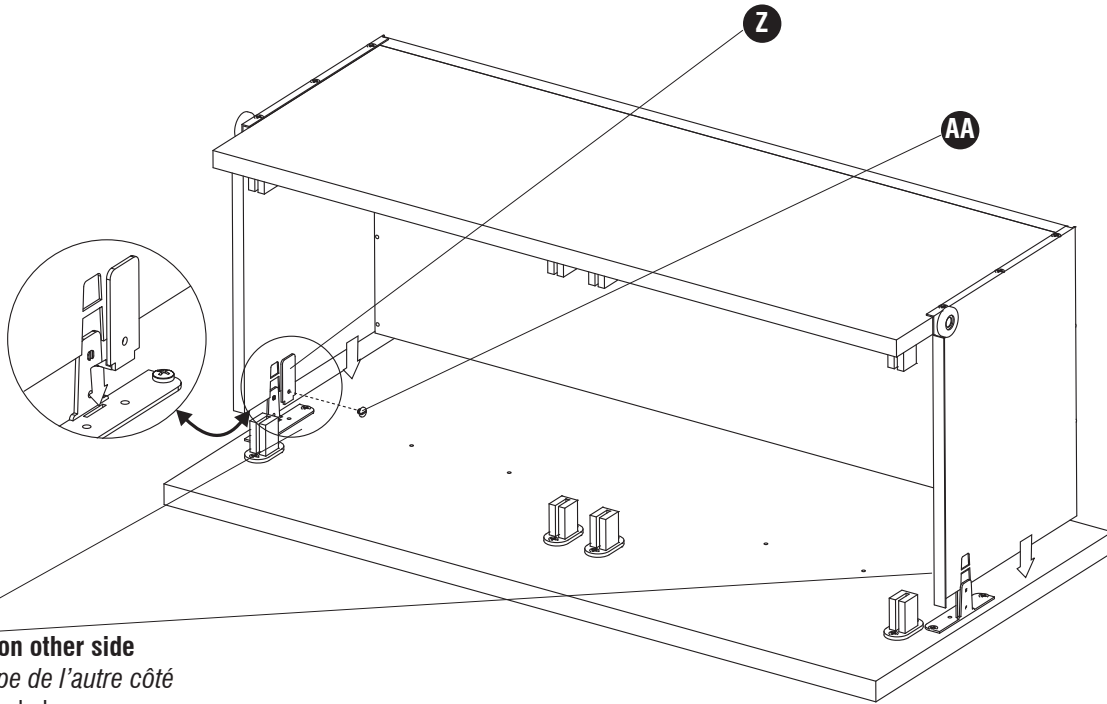

Repeat step on other side
Répétez l'étape de l'autre côté
Repita del otro lado

U (2) V (4)

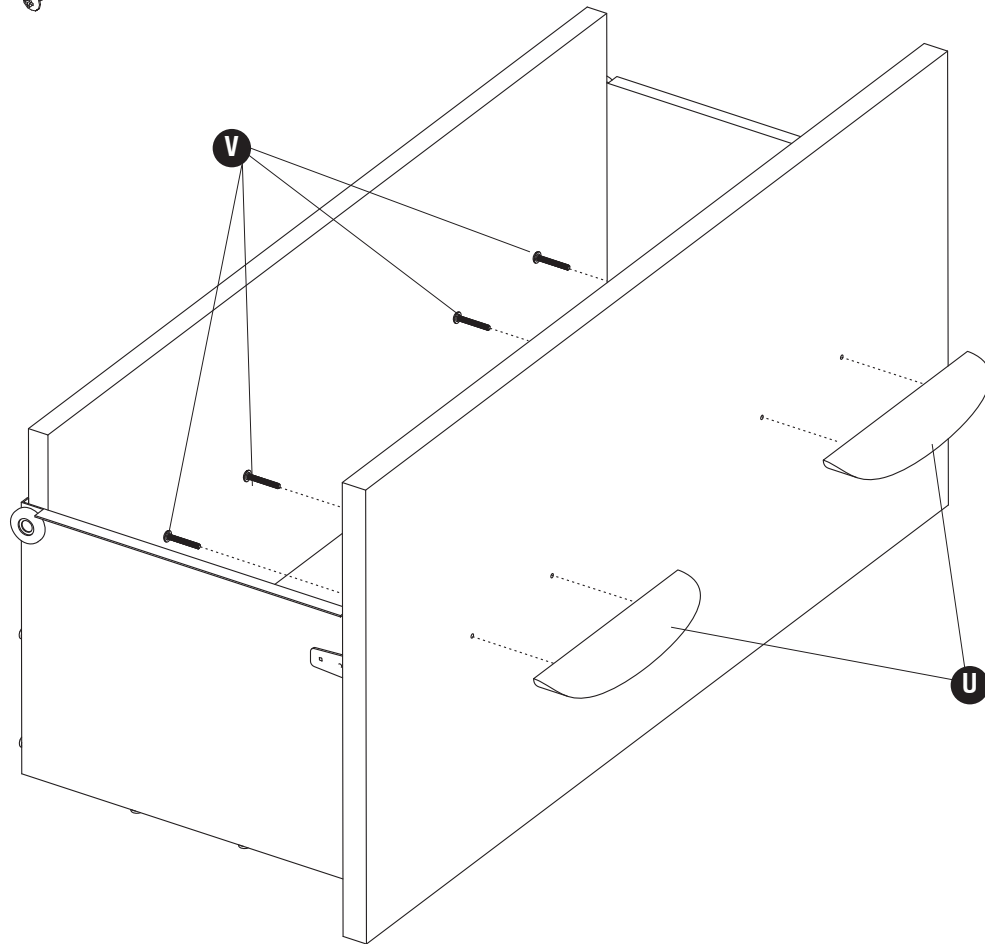

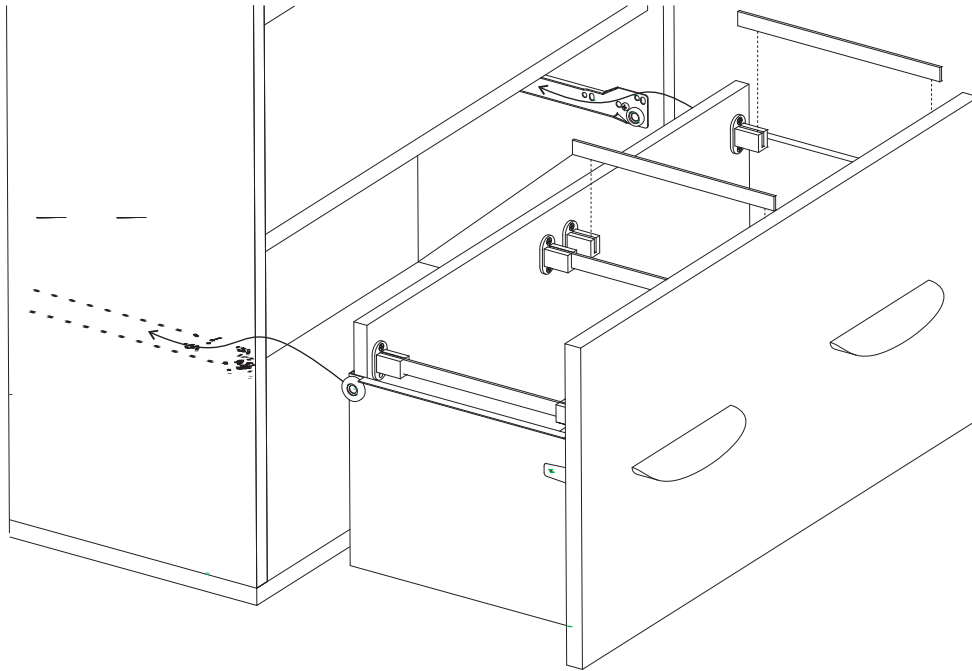

§Note: Loosen the 4 screws (#3695-28) allowing the drawer front to move for adjustment. Place the drawer in the cabinet (refer to step 11), adjust drawer front to fit between the side panels. Re-tighten screws.

§ Note: Dévissez les 4 vis (# 3695-28), qui permet à la façade de tiroir pour être ajusté. Placez le tiroir dans le tiroir de l'espace (voir l'étape 11), ajustez le tiroir avant d'adéquation entre les panneaux latéraux. Re-serrer les vis.

§ Note: Desenrosque los 4 tornillos (# 3695-28), que permite que el cajón delantero que se han de ajustar. Coloque el cajón en el cajón el espacio (véase el paso 11), ajuste el cajón delante para encajar entre los paneles laterales.

Vuelva a apretar los tornillos.

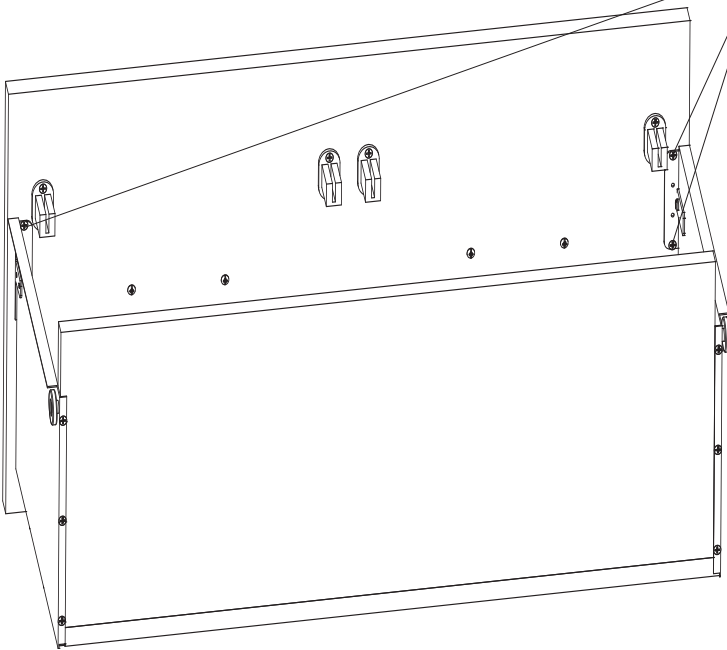

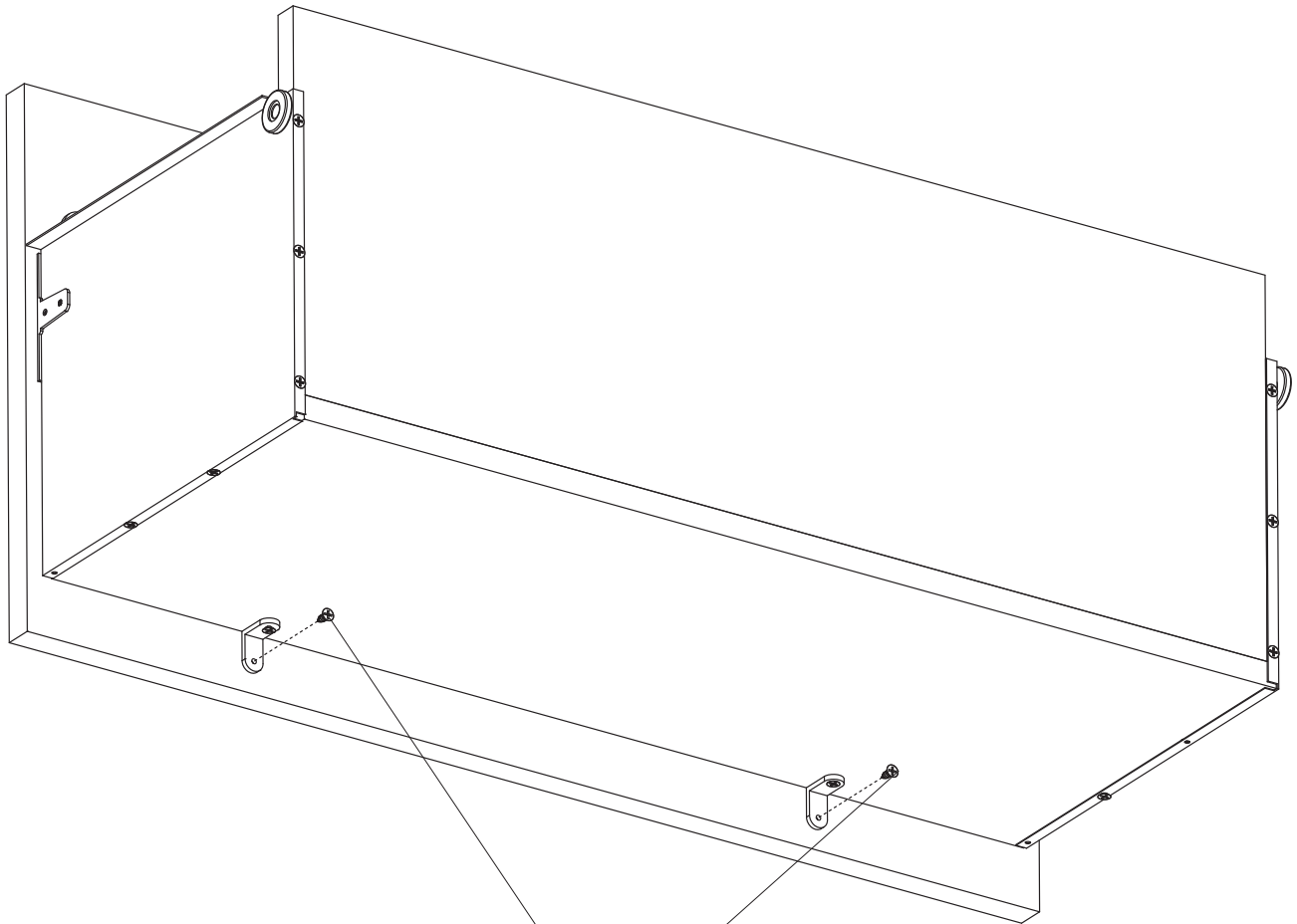
X

Note: Remove drawer and fasten screws (3695-28) to drawer front .

Noter: Retirez le tiroir et fixez les vis (3695-28) Tiroir à l'avant.

Note: Retire el cajón y coloque los tornillos (3695-28) en la parte delantera del cajón.

X

Note: for connecting adjacent units only; use cap on exposed holes.

Noter: pour relier les unités adjacentes seulement; le utiliser couvercle sur exposé trou.

Note: para conectar unidades adyacentes solamente; uso madera tapon para cubrir el agujero

Warning: Do not stack this unit on top of other units. This unit must be used on the bottom only.
Attention: Ne pas empiler cette unité au-dessus des autres unités. Cet appareil doit être utilisé uniquement sur le fond.

Advertencia: No coloque para esta unidad por encima de las otras unidades. Esta unidad debe utilizarse sólo en la parte inferior.