

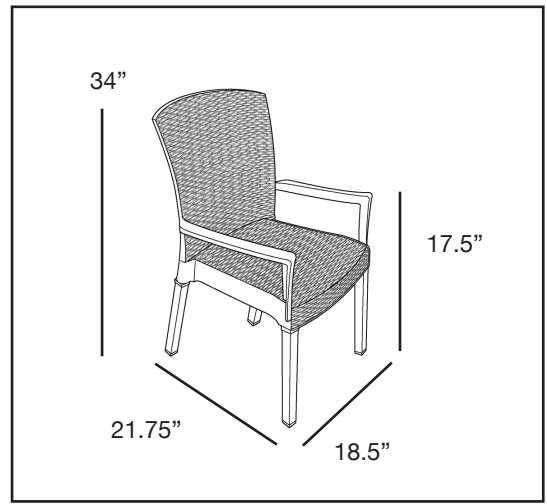

# Havana Stacking Armchair



## Product Specifications

Product Description	Reference Number	Color	UPC Code 014306	Weight Each (lbs.)	Master Pack	Master Pack Volume (cu. ft)
Havana Stacking Armchair	45903037	Espresso	912141	13.30	12	60.29
	45903008	Tobacco	912158	13.30	12	60.29
	45903002	Charcoal	912172	13.30	12	60.29
	45903004	White	912165	13.30	12	60.29
	US903037	Espresso	912141	12.42	4	21.60
	US903008	Tobacco	912158	12.42	4	21.60
	US903002	Charcoal	912172	12.42	4	21.60
	US903004	White	912165	12.42	4	21.60

## Features & Benefits Warranty: 3 Yrs.

- Tested in accordance with and passes each test procedure utilized in ASTM F 1561-96 Class B performance standard for commercial outdoor seating.
- A product of Grosfillex MPC Technology®
- Designer’s Choice with a decorative wicker finish texture - front and back.
- Texture will not harbor dirt, germs, bacteria, nor fungi.
- Easy to clean with soap or a mild detergent and water.
- Rated to 300 lbs. for safe use in commercial environments.
- 1 1/4” square powder coated aluminum legs with hard wearing footpads for structural integrity.
- Stacks for easy storage.

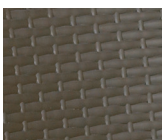

Espresso



Tobacco

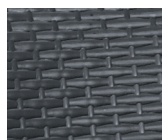

Charcoal



White

