

TelCom® Telephone Extension Ringer Device

Model TELB



DESIGNED FOR USE WITH A TELEPHONE

- Available in 120VAC
- Bell signals an incoming call
- Activated by ringing voltage
- Type 1 enclosure
- CSA Certified
- FCC Approved
- UL Listed for indoor use

Federal Signal's TELB TelCom® Extension Ringer Device is a vibrating bell which is activated by the ringing signal of a telephone system. The TELB is specifically designed for use with an analog telephone. The ringing signal of 40-150VAC, 16-60Hz and local 120VAC power is all that is required to activate a TelCom signal.

This TelCom device is intended to be mounted on a vertical surface such as a rigid wall or post. The TELB has a three-conductor six-foot, 120VAC power cord extending from the unit. Connecting the TelCom device to the telephone network is done by running a modular telephone line cord (RJ11) to an existing jack or a duplex jack (customer supplied) into an existing modular jack. The TELB is designed with a durable zinc die-cast housing painted with gray powder coat enamel, and features an internal solid-state relay.

Telcom devices are designed for high ambient noise areas such as manufacturing facilities, machine and sheet metal shops. They are also useful in large open areas such as a warehouse, loading dock, or a large office.

This four-inch bell produces a 98dB signal @ 10' (108dB @ 1m).

Model	Voltage	Operating Current	Decibels @	
			10'	1m
TELB	120VAC	0.08 amps	98	108



TELEPHONE EXTENSION RINGER DEVICE (TELB)

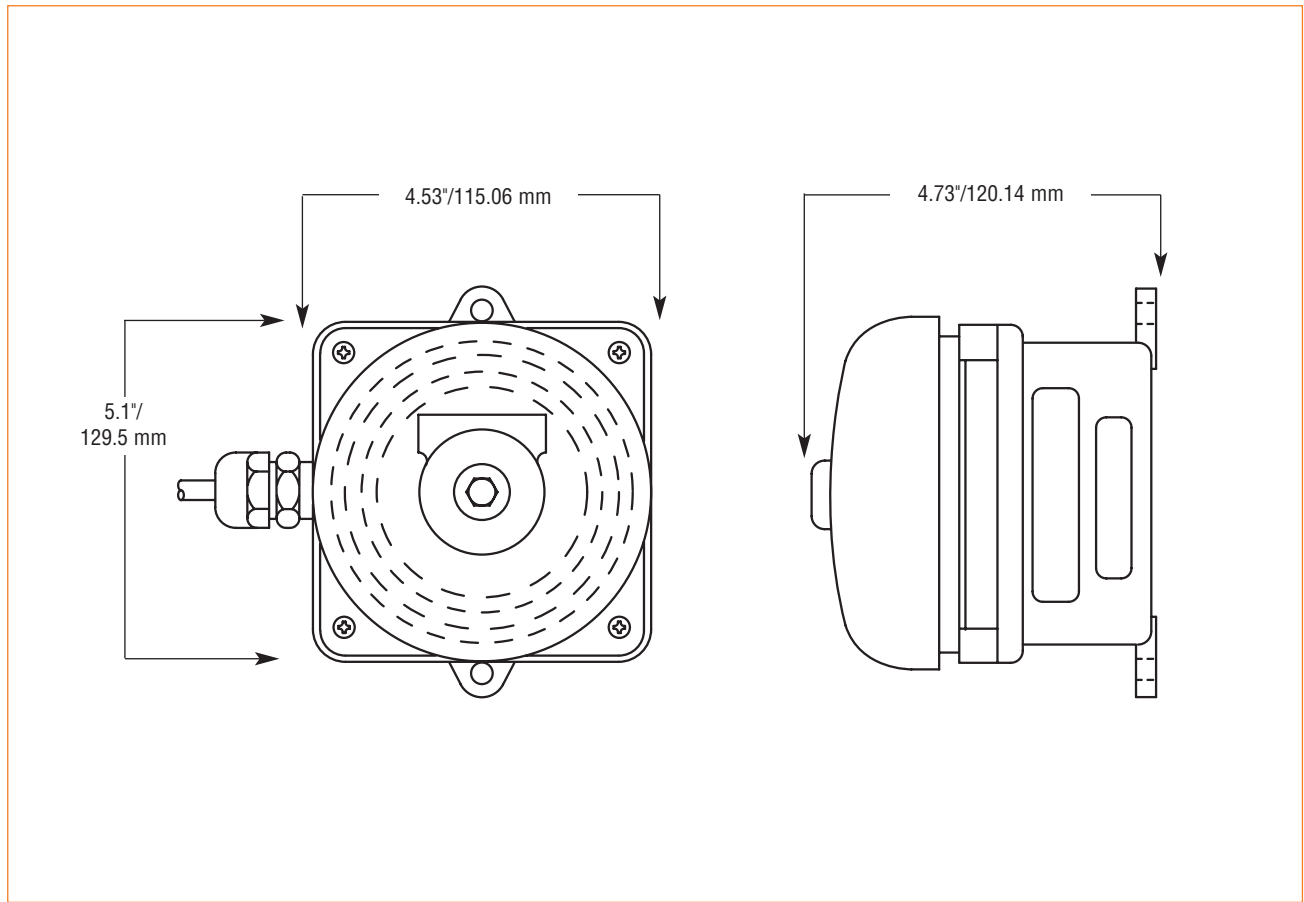

SPECIFICATIONS

Operating Temperature:	32°F to 112°F	0°C to 44°C
Ringing Signal:	90VAC, 20Hz	90VAC, 20Hz
Ring Detection:		15.8-60Hz, 40-150VAC
Humidity Range (Storage and Operating):	0 to 85% R.H, noncondensing	
FCC Ringer Equivalence Number (REN):		1.0B
Net Weight:	2.6 lbs.	1.18 kg
Shipping Weight:	3.2 lbs.	1.45 kg
Height:	5.1"	129.5 mm
Width:	4.53"	115.06 mm
Depth:	4.73"	120.14 mm

HOW TO ORDER

- Specify model number
- Please refer to Model Number Index TELB beginning on page 381

REPLACEMENT PARTS

<u>Description</u>	<u>Part Number</u>
PCBA, TelCom	K200C1047D