



No.:

Date: 19-DEC-2012

Customer :

TECHNICAL PROPOSAL

Three-phase induction motor - Squirrel cage rotor

Product line : Three-Phase : ODP (IP21/IP23) - NEMA Premium Efficiency

Catalog Number : 00218OT3E145T

List Price : \$492

Notes:

Performed by:

Checked:



No.:

Date: 19-DEC-2012

## DATA SHEET

### Three-phase induction motor - Squirrel cage rotor

Customer :  
Product line : Three-Phase : ODP (IP21/IP23) - NEMA Premium Efficiency

Frame : E143/5T  
Output : 2 HP  
Frequency : 60 Hz  
Poles : 4  
Full load speed : 1730  
Slip : 3.89 %  
Voltage : 208-230/460 V  
Rated current : 5.95-5.80/2.90 A  
Locked rotor current : 47.6/23.8 A  
Locked rotor current (I<sub>L</sub>/I<sub>n</sub>) : 8.2  
No-load current : 3.20/1.60 A  
Full load torque : 5.99 lb.ft  
Locked rotor torque : 350 %  
Breakdown torque : 330 %  
Design : B  
Insulation class : F  
Temperature rise : 80 K  
Locked rotor time : 15 s (hot)  
Service factor : 1.15 (1.00 at 208V)  
Duty cycle : S1  
Ambient temperature : -20°C - +40°C  
Altitude : 1000  
Degree of Protection : IP21  
Approximate weight : 44 lb  
Moment of inertia : 0.15970 sq.ft.lb  
Noise level : ---

	D.E.	N.D.E.	Load	Power factor	Efficiency (%)
Bearings	6205 ZZ	6204 ZZ	100%	0.78	86.5
Regreasing interval	---	---	75%	0.70	85.5
Grease amount	---	---	50%	0.58	82.5

Notes:

Performed by

Checked



No.:

Date: 19-DEC-2012

### PERFORMANCE CURVES RELATED TO RATED OUTPUT Three-phase induction motor - Squirrel cage rotor

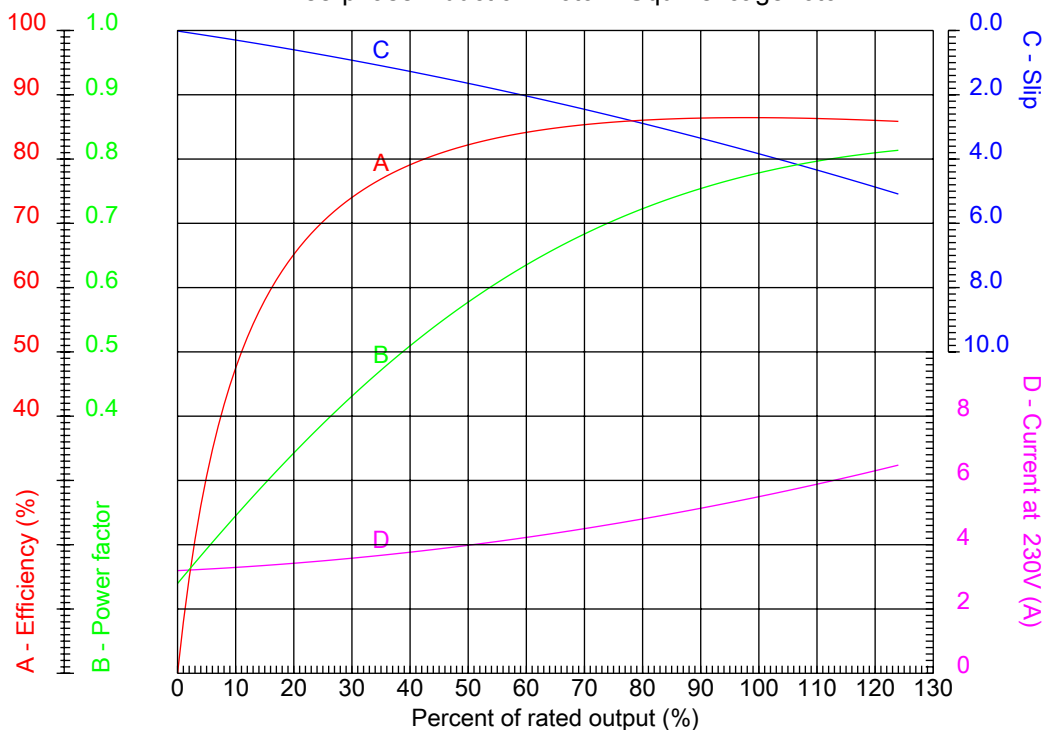

Customer :  
Product line : Three-Phase : ODP (IP21/IP23) - NEMA Premium Efficiency

Frame	: E143/5T	Locked rotor current (I <sub>l</sub> /I <sub>n</sub> )	: 8.2
Output	: 2 HP	Duty cycle	: S1
Frequency	: 60 Hz	Service factor	: 1.15 (1.00 at 208V)
Full load speed	: 1730	Design	: B
Voltage	: 208-230/460 V	Locked rotor torque	: 350 %
Rated current	: 5.95-5.80/2.90 A	Breakdown torque	: 330 %
Insulation class	: F		

Notes:

Performed by

Checked



No.:

Date: 19-DEC-2012

### CHARACTERISTIC CURVES RELATED TO SPEED

Three-phase induction motor - Squirrel cage rotor

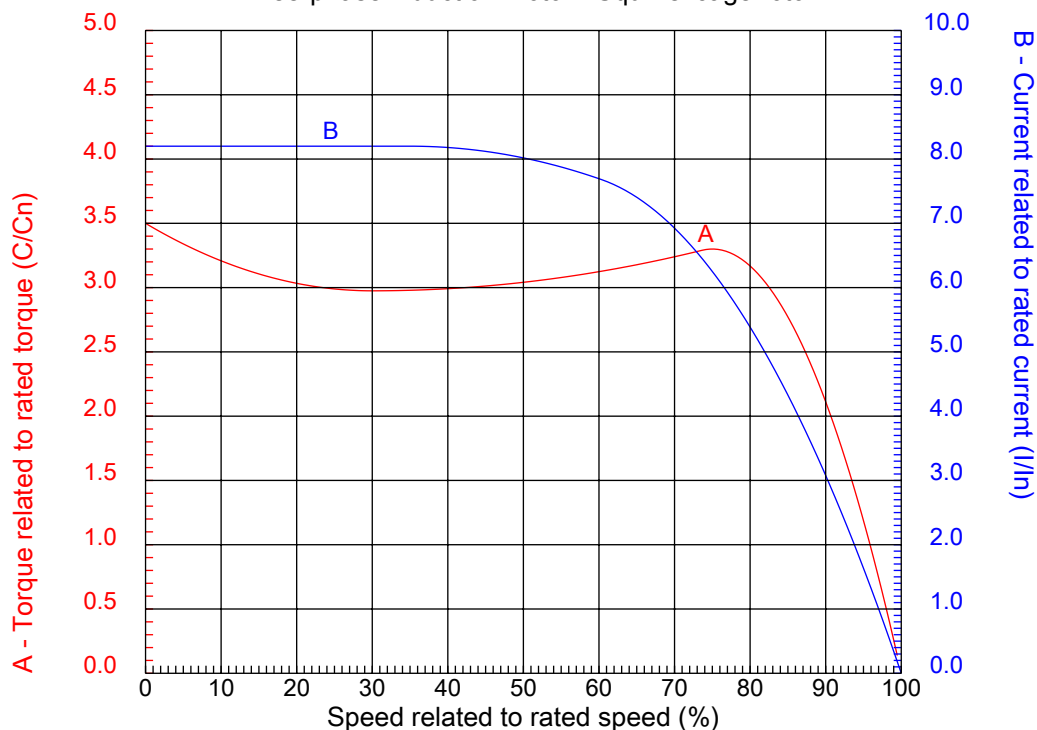

Customer :  
Product line : Three-Phase : ODP (IP21/IP23) - NEMA Premium Efficiency

Frame	: E143/5T	Locked rotor current (I <sub>l</sub> /I <sub>n</sub> )	: 8.2
Output	: 2 HP	Duty cycle	: S1
Frequency	: 60 Hz	Service factor	: 1.15 (1.00 at 208V)
Full load speed	: 1730	Design	: B
Voltage	: 208-230/460 V	Locked rotor torque	: 350 %
Rated current	: 5.95-5.80/2.90 A	Breakdown torque	: 330 %
Insulation class	: F		

Notes:

Performed by

Checked

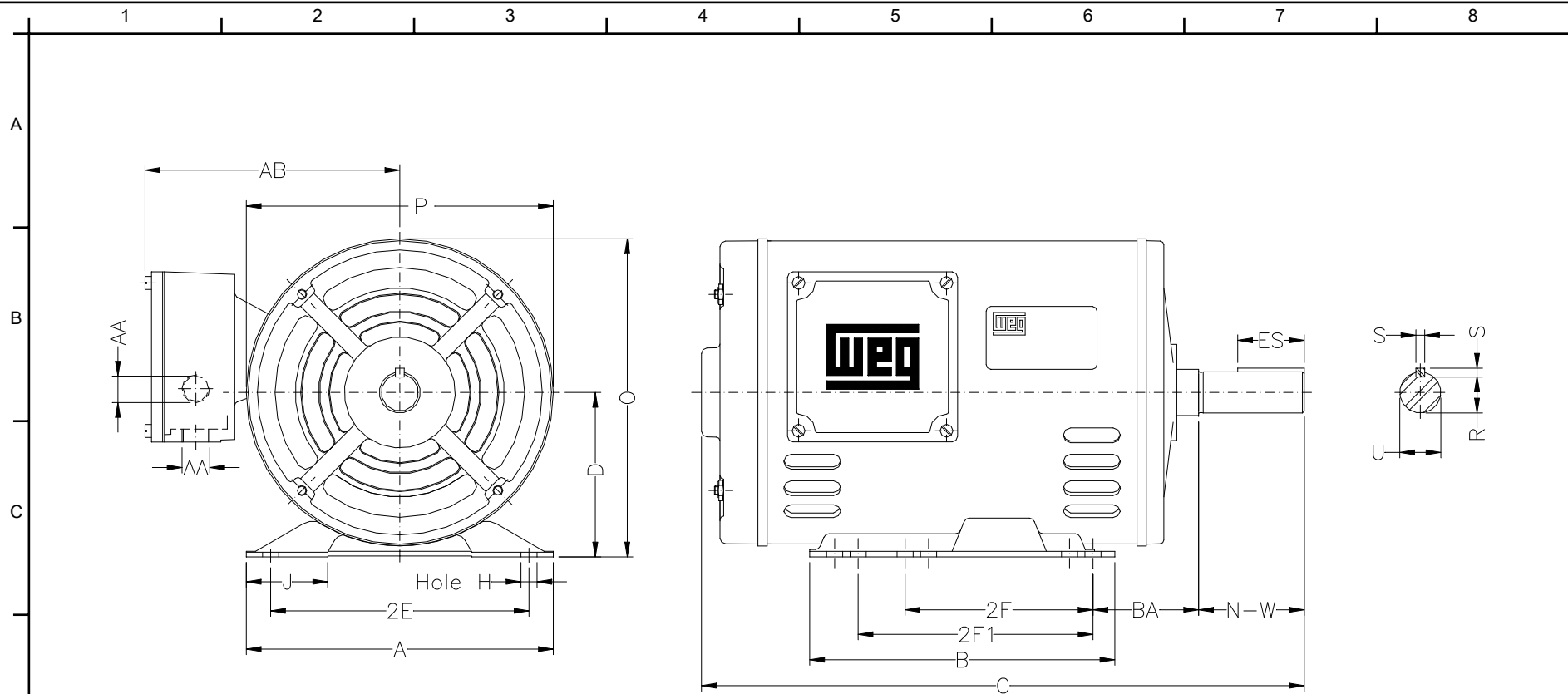

Notes:

Performed by:

Checked:

Customer:

Three-Phase : ODP (IP21/IP23) - NEMA Premium Efficiency

Three-phase induction motor  
Frame E143/5T - IP21

19-DEC-2012



2E 5.500	A 6.535	2F 4.000/5.000	B 6.496	BA 2.250
J 1.732	K 1.988	P 6.535	ES 1.417	depth 0.187
S 0.187	D 3.500	N-W 2.250	G 0.120	U 0.8750
O 6.772	T 653.228	HD 660	R 0.766	H 0.342
C 12.047	AA 2XNPT 1/2"	Flange C	AJ 5.874	AK 4.500
BD 6.535	BF UNC 3/8"x16	BB 0.157	BC ---	AH