



No.:

Date: 20-DEC-2012

Customer :

TECHNICAL PROPOSAL

Three-phase induction motor - Squirrel cage rotor

Product line : Three-Phase : ODP (IP21/IP23) - NEMA Premium Efficiency

Catalog Number : 07536OT3H364TS

List Price : \$5,799

Notes:

Performed by:

Checked:



No.:

Date: 20-DEC-2012

DATA SHEET

Three-phase induction motor - Squirrel cage rotor

Customer :
Product line : Three-Phase : ODP (IP21/IP23) - NEMA Premium Efficiency

Frame : 364TS
Output : 75 HP
Frequency : 60 Hz
Poles : 2
Full load speed : 3550
Slip : 1.39 %
Voltage : 575 V
Rated current : 65.2 A
Locked rotor current : 424 A
Locked rotor current (I_L/I_n) : 6.5
No-load current : 17.6 A
Full load torque : 109 lb.ft
Locked rotor torque : 180 %
Breakdown torque : 280 %
Design : B
Insulation class : F
Temperature rise : 80 K
Locked rotor time : 14 s (hot)
Service factor : 1.15
Duty cycle : S1
Ambient temperature : -20°C - +40°C
Altitude : 1000
Degree of Protection : IP23
Approximate weight : 526 lb
Moment of inertia : 6.8107 sq.ft.lb
Noise level : 80 dB(A)

| | D.E. | N.D.E. | Load | Power factor | Efficiency (%) |
|---------------------|---------|---------|------|--------------|----------------|
| Bearings | 6314 C3 | 6314 C3 | 100% | 0.90 | 94.1 |
| Regreasing interval | 14418 h | 14418 h | 75% | 0.88 | 94.1 |
| Grease amount | 27 g | 27 g | 50% | 0.83 | 93.6 |

Notes:

Performed by

Checked



No.:

Date: 20-DEC-2012

PERFORMANCE CURVES RELATED TO RATED OUTPUT

Three-phase induction motor - Squirrel cage rotor

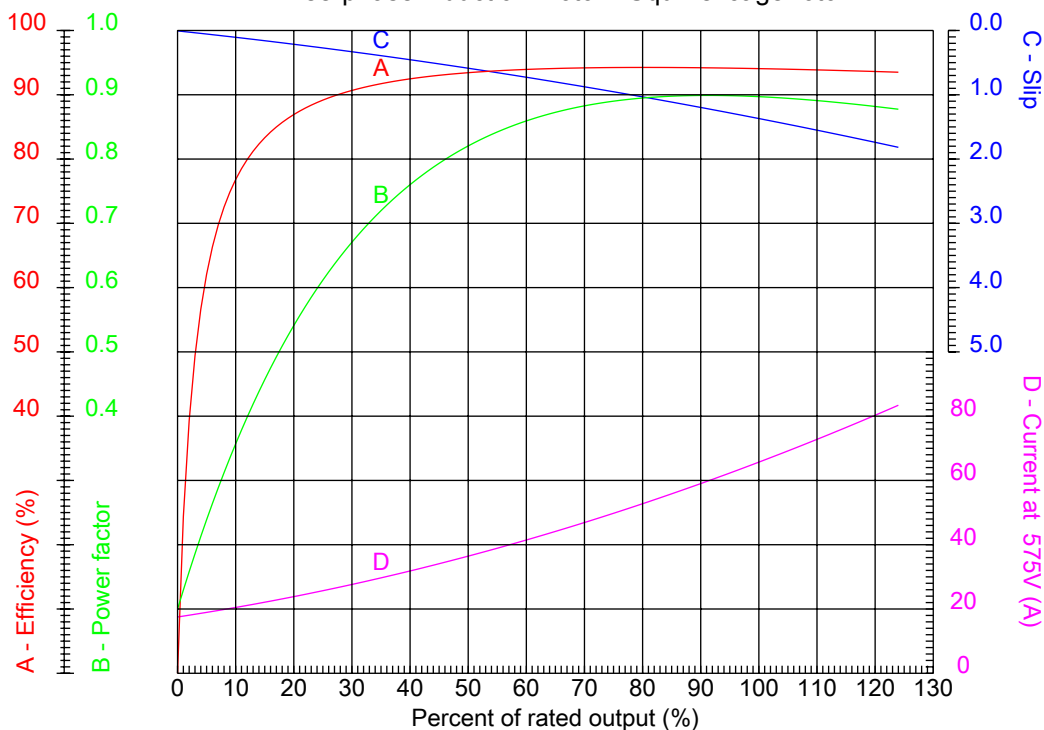

Customer :
Product line : Three-Phase : ODP (IP21/IP23) - NEMA Premium Efficiency

| | |
|------------------------|--|
| Frame : 364TS | Locked rotor current (I _L /I _n) : 6.5 |
| Output : 75 HP | Duty cycle : S1 |
| Frequency : 60 Hz | Service factor : 1.15 |
| Full load speed : 3550 | Design : B |
| Voltage : 575 V | Locked rotor torque : 180 % |
| Rated current : 65.2 A | Breakdown torque : 280 % |
| Insulation class : F | |

Notes:

Performed by

Checked



No.:

Date: 20-DEC-2012

CHARACTERISTIC CURVES RELATED TO SPEED Three-phase induction motor - Squirrel cage rotor

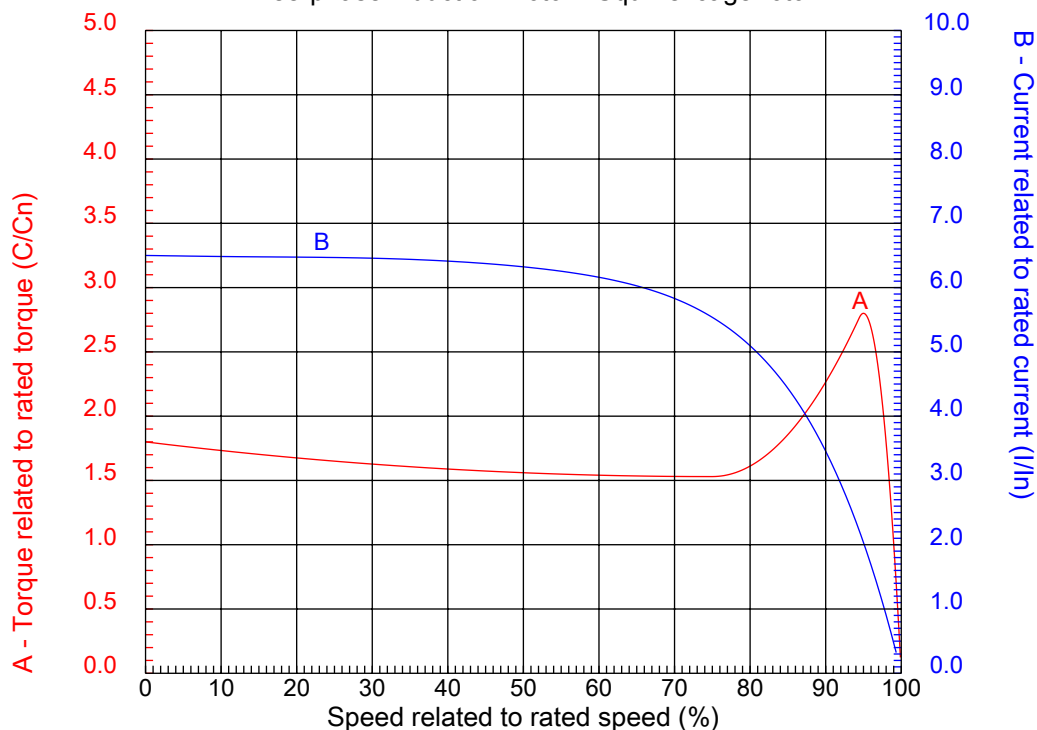

Customer :
Product line : Three-Phase : ODP (IP21/IP23) - NEMA Premium Efficiency

| | | | |
|------------------|----------|--|---------|
| Frame | : 364TS | Locked rotor current (I _l /I _n) | : 6.5 |
| Output | : 75 HP | Duty cycle | : S1 |
| Frequency | : 60 Hz | Service factor | : 1.15 |
| Full load speed | : 3550 | Design | : B |
| Voltage | : 575 V | Locked rotor torque | : 180 % |
| Rated current | : 65.2 A | Breakdown torque | : 280 % |
| Insulation class | : F | | |

Notes:

Performed by

Checked

A
B
C
D
E

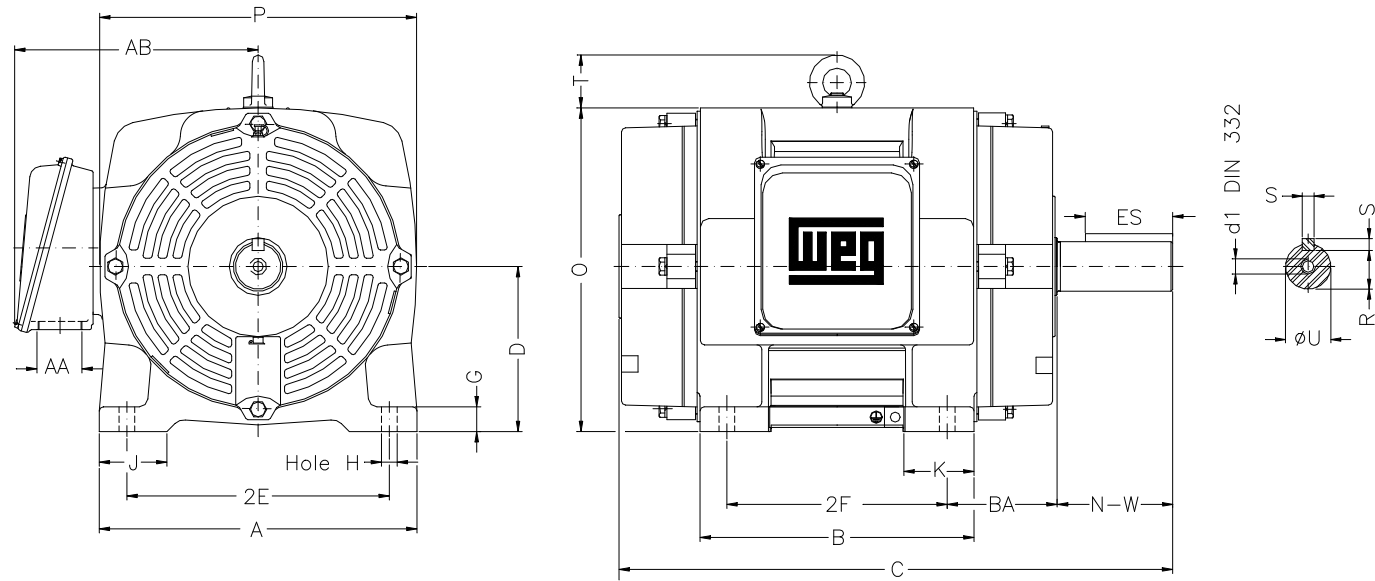

Notes:

| | | | | |
|------------------|--------------|---------------------|--------------------|--------------------|
| 2E 14.000 | A 17.170 | 2F 11.250/12.250 | B 15.400 | BA 5.875 |
| J 3.150 | K 4.140 | P 17.874 | ES 1.968 | depth 0.500 |
| S 0.500 | D 9.000 | N-W 3.748 | G 1.480 | U 1.875 |
| O 18.425 | T 2.795 | HD 21.220 | R 1.591 | H 0.657 |
| AB 16.378 | C 27.638 | AA NPT 3" | d1 DUNC 3/4"-10 | d2 DUNC 3/4"-10 |
| Flange FD-406 | AJ 16.000 | AK 14.000 | BD 17.716 | BF 0.828 |
| BB 0.250 | | | | |

Performed by:

Checked:

Customer:

Three-Phase : ODP (IP21/IP23) - NEMA Premium Efficiency

Three-phase induction motor
Frame 364TS - IP23

20-DEC-2012

