



No.:

Date: 21-DEC-2012

Customer :

TECHNICAL PROPOSAL

Three-phase induction motor - Squirrel cage rotor

Product line : W22 Super Premium

Catalog Number : 00718EG3EL213T-W22

List Price : \$1,198

Notes:

Performed by:

Checked:



No.:

Date: 21-DEC-2012

DATA SHEET

Three-phase induction motor - Squirrel cage rotor

Customer :
Product line : W22 Super Premium

Frame : L213T
Output : 7.5 HP
Frequency : 60 Hz
Poles : 4
Full load speed : 1770
Slip : 1.67 %
Voltage : 208-230/460 V
Rated current : 17.9/8.94 A
Locked rotor current : 152/76.0 A
Locked rotor current (I_L/I_n) : 8.5
No-load current : 9.00/4.50 A
Full load torque : 22.0 lb.ft
Locked rotor torque : 230 %
Breakdown torque : 350 %
Design : A
Insulation class : F
Temperature rise : 80 K
Locked rotor time : 20 s (hot)
Service factor : 1.25 (1.00 at 208V)
Duty cycle : S1
Ambient temperature : -20°C - +40°C
Altitude : 1000
Degree of Protection : IP55
Approximate weight : 172 lb
Moment of inertia : 1.5144 sq.ft.lb
Noise level : 58 dB(A)

	D.E.	N.D.E.	Load	Power factor	Efficiency (%)
Bearings	6308 ZZ	6207 ZZ	100%	0.83	93.0
Regreasing interval	---	---	75%	0.76	92.4
Grease amount	---	---	50%	0.65	91.0

Notes:

Performed by

Checked



No.:

Date: 21-DEC-2012

PERFORMANCE CURVES RELATED TO RATED OUTPUT

Three-phase induction motor - Squirrel cage rotor

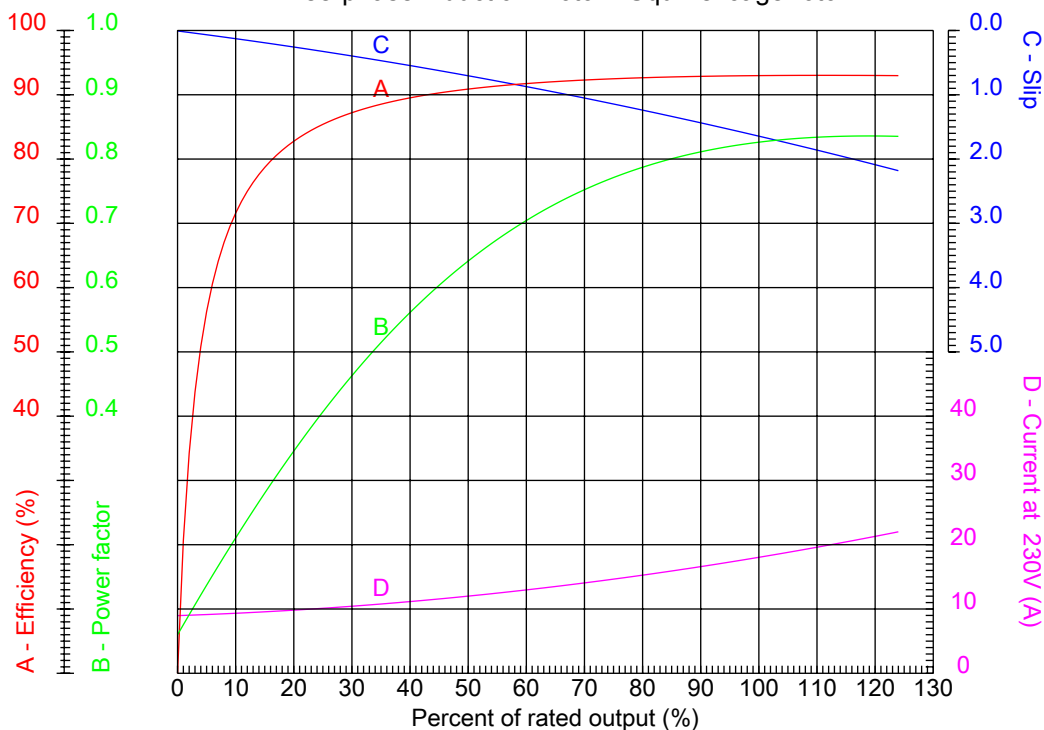

Customer :
Product line : W22 Super Premium

Frame : L213T	Locked rotor current (I _l /I _n) : 8.5
Output : 7.5 HP	Duty cycle : S1
Frequency : 60 Hz	Service factor : 1.25 (1.00 at 208V)
Full load speed : 1770	Design : A
Voltage : 208-230/460 V	Locked rotor torque : 230 %
Rated current : 17.9/8.94 A	Breakdown torque : 350 %
Insulation class : F	

Notes:

Performed by

Checked



No.:

Date: 21-DEC-2012

CHARACTERISTIC CURVES RELATED TO SPEED

Three-phase induction motor - Squirrel cage rotor

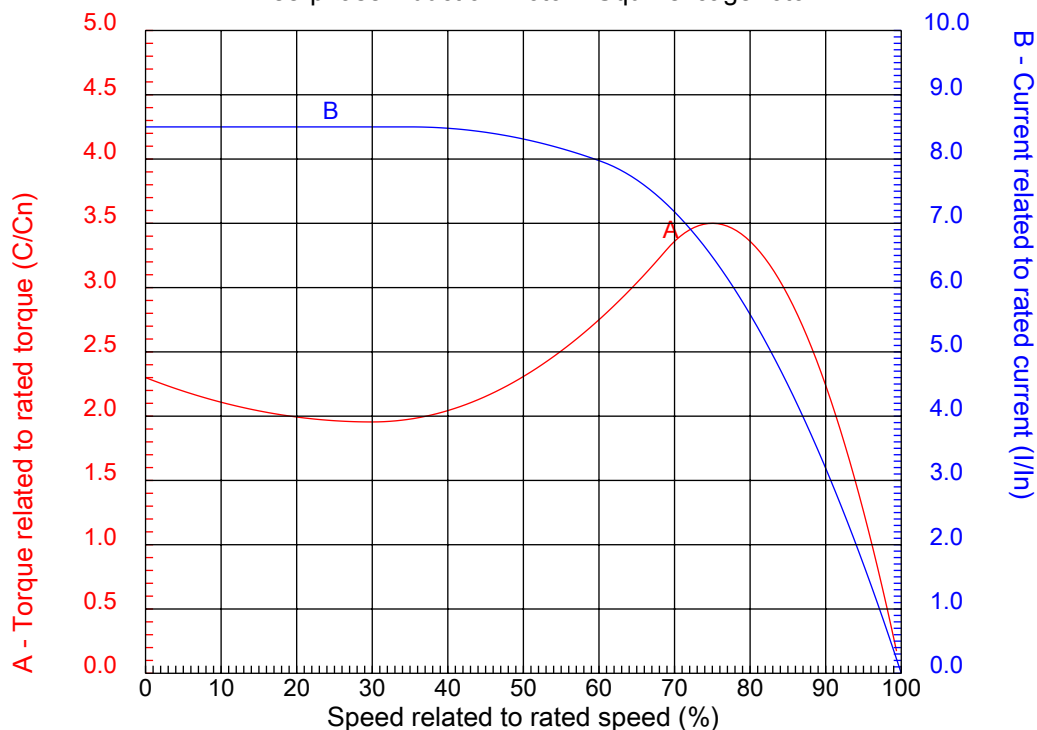

Customer :
Product line : W22 Super Premium

Frame	: L213T	Locked rotor current (I _l /I _n)	: 8.5
Output	: 7.5 HP	Duty cycle	: S1
Frequency	: 60 Hz	Service factor	: 1.25 (1.00 at 208V)
Full load speed	: 1770	Design	: A
Voltage	: 208-230/460 V	Locked rotor torque	: 230 %
Rated current	: 17.9/8.94 A	Breakdown torque	: 350 %
Insulation class	: F		

Notes:

Performed by

Checked

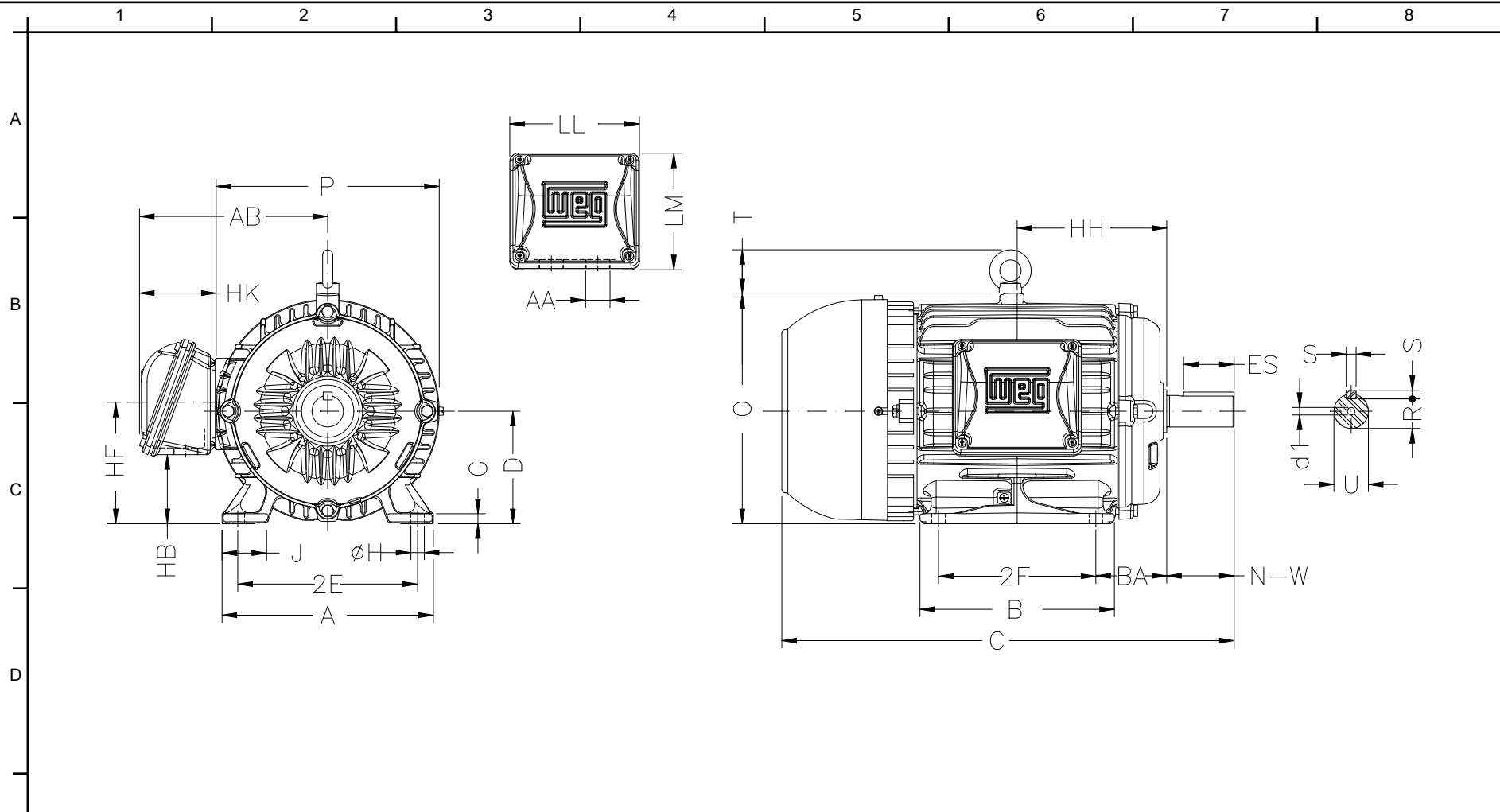

E	2E 8.500	J 1.988	A 9.764	P 10.669	AB 8.583
	2F 5.500	K 2.165	B 7.362	BA 3.500	FBA 5.921
	U 1.375	N-W 3.375	ES 2.480	S 0.313	R 1.203
	depth 0.313	D 5.250	G 0.827	HB 3.006	O 10.841
	T 1.772	HD 12.613	HF 5.250	HH 6.250	HK 3.110
F	H 0.406	C 19.083	LL 5.512	LM 5.236	AA NPT 1"
	d1 A 4	d2 A 4	Flange FD-254	AJ 10.000	AK 9.000
	BD 11.00	BF 0.562	BB 0.203		

Notes:		
Performed by:		
Checked:		
Customer:		
W22 Super Premium		
Three-phase induction motor	21-DEC-2012	
Frame L213T - IP55		