



No.:

Date: 21-DEC-2012

Customer :

TECHNICAL PROPOSAL

Three-phase induction motor - Squirrel cage rotor

Product line : W22 Super Premium

Catalog Number : 06018EG3E364T-W22

List Price : \$8,128

Notes:

Performed by:

Checked:



No.:

Date: 21-DEC-2012

DATA SHEET

Three-phase induction motor - Squirrel cage rotor

Customer :
Product line : W22 Super Premium

Frame : 364/5T
Output : 60 HP
Frequency : 60 Hz
Poles : 4
Full load speed : 1780
Slip : 1.11 %
Voltage : 208-230/460 V
Rated current : 155-140/70.2 A
Locked rotor current : 1070/534 A
Locked rotor current (I_L/I_n) : 7.6
No-load current : 60.0/30.0 A
Full load torque : 175 lb.ft
Locked rotor torque : 270 %
Breakdown torque : 320 %
Design : A
Insulation class : F
Temperature rise : 80 K
Locked rotor time : 24 s (hot)
Service factor : 1.25
Duty cycle : S1
Ambient temperature : -20°C - +40°C
Altitude : 1000
Degree of Protection : IP55
Approximate weight : 897 lb
Moment of inertia : 23.277 sq.ft.lb
Noise level : 67 dB(A)

	D.E.	N.D.E.	Load	Power factor	Efficiency (%)
Bearings	6314 C3	6314 C3	100%	0.84	95.8
Regreasing interval	12000 h	12000 h	75%	0.80	95.4
Grease amount	27 g	27 g	50%	0.69	94.5

Notes:

Performed by

Checked



No.:

Date: 21-DEC-2012

PERFORMANCE CURVES RELATED TO RATED OUTPUT
Three-phase induction motor - Squirrel cage rotor

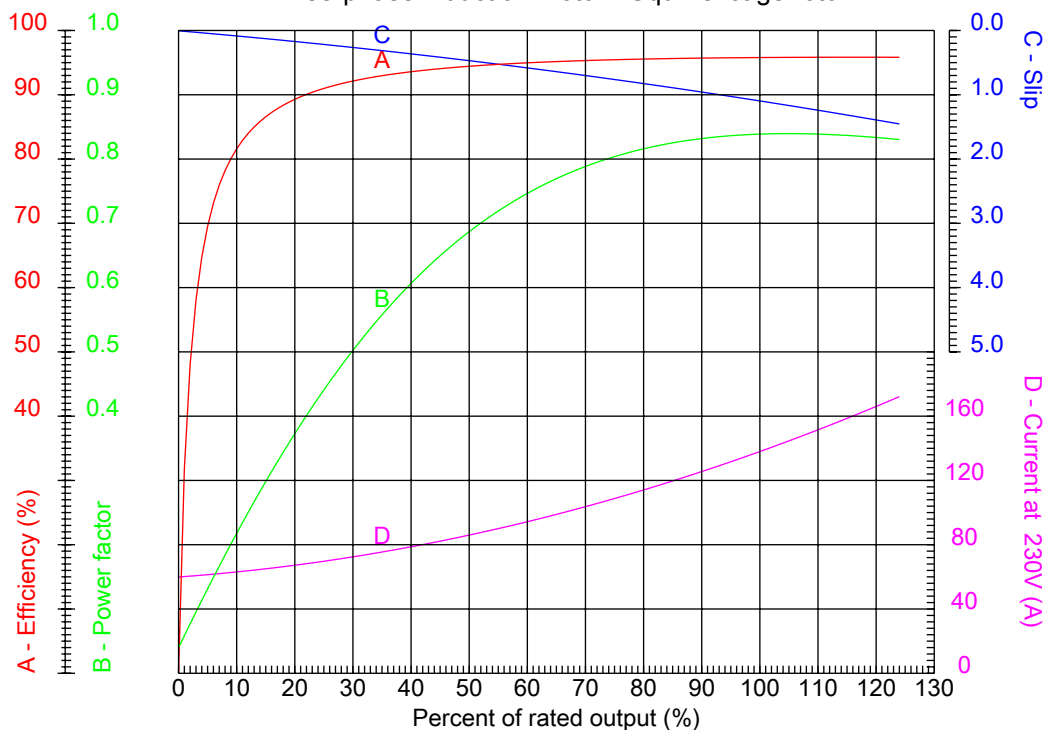

Customer :
Product line : W22 Super Premium

Frame	: 364/5T	Locked rotor current (I _l /I _n)	: 7.6
Output	: 60 HP	Duty cycle	: S1
Frequency	: 60 Hz	Service factor	: 1.25
Full load speed	: 1780	Design	: A
Voltage	: 208-230/460 V	Locked rotor torque	: 270 %
Rated current	: 155-140/70.2 A	Breakdown torque	: 320 %
Insulation class	: F		

Notes:

Performed by

Checked



No.:

Date: 21-DEC-2012

CHARACTERISTIC CURVES RELATED TO SPEED

Three-phase induction motor - Squirrel cage rotor

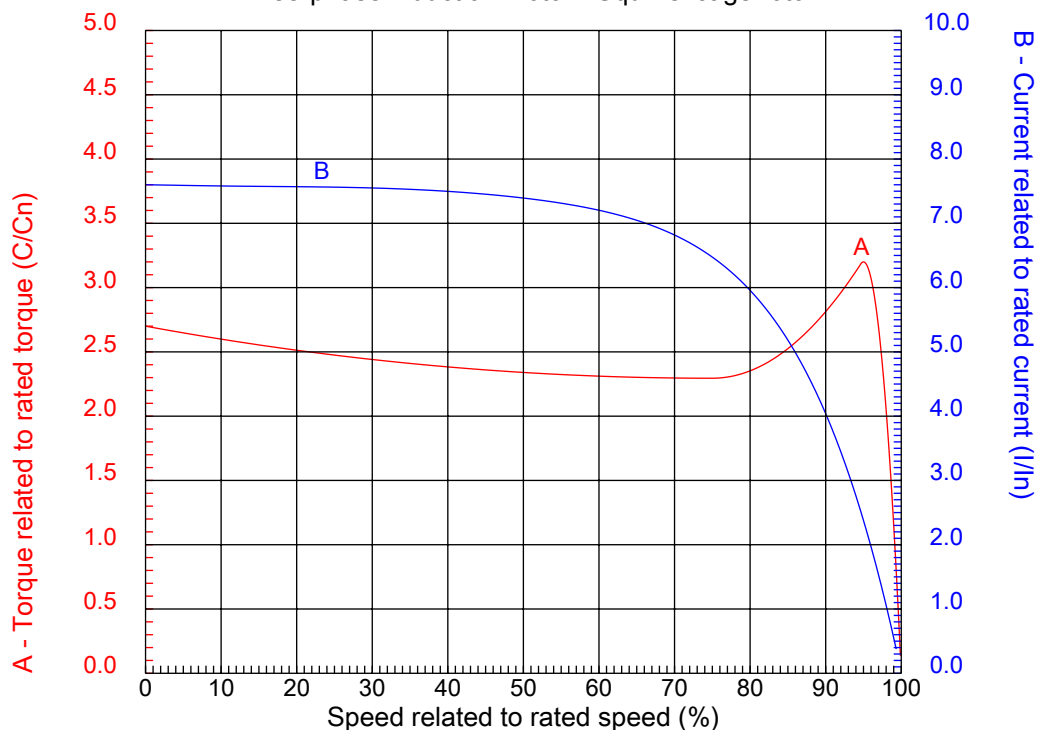

Customer :
Product line : W22 Super Premium

Frame	: 364/5T	Locked rotor current (I _l /I _n)	: 7.6
Output	: 60 HP	Duty cycle	: S1
Frequency	: 60 Hz	Service factor	: 1.25
Full load speed	: 1780	Design	: A
Voltage	: 208-230/460 V	Locked rotor torque	: 270 %
Rated current	: 155-140/70.2 A	Breakdown torque	: 320 %
Insulation class	: F		

Notes:

Performed by

Checked

1 2 3 4 5 6 7 8

A

B

C

D

E

F

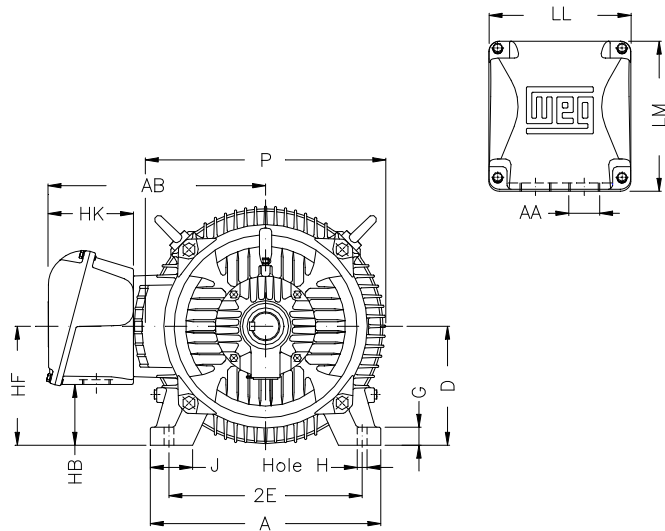

Notes:

Performed by:

Checked:

Customer:

W22 Super Premium

Three-phase induction motor
Frame 364/5T - IP55

21-DEC-2012



2E 14.016	J 3.150	A 17.165	P 17.914	AB 16.023
2F 11.260/12.244	K 4.134	B 15.512	BA 5.875	U 2.375
N-W 5.874	ES 4.330	S 0.625	R 2.019	depth 0.625
D 9.000	G 1.480	HB 2.992	O 17.957	T 6.255
HD 24.212	HH 8.346	HK 6.023	H 0.660	C 34.251
LL 10.590	LM 11.181	AA NPT 3"	d1 DUNC 3/4"-10	d2 DUNC 3/4"-10
Flange FD-406	AJ 16.000	AK 14.000	BD 17.71	BF 0.828
BB 0.203				