



No.:

Date: 21-DEC-2012

Customer :

TECHNICAL PROPOSAL

Three-phase induction motor - Squirrel cage rotor

Product line : W22 Super Premium

Catalog Number : 20036EG3G447TS-W22

List Price : \$25,918

Notes:

Performed by:

Checked:



No.:

Date: 21-DEC-2012

## DATA SHEET

### Three-phase induction motor - Squirrel cage rotor

Customer :  
Product line : W22 Super Premium

Frame : 445/7TS  
Output : 200 HP  
Frequency : 60 Hz  
Poles : 2  
Full load speed : 3575  
Slip : 0.69 %  
Voltage : 460 V  
Rated current : 217 A  
Locked rotor current : 1580 A  
Locked rotor current (I<sub>L</sub>/I<sub>n</sub>) : 7.3  
No-load current : 53.0 A  
Full load torque : 290 lb.ft  
Locked rotor torque : 240 %  
Breakdown torque : 290 %  
Design : A  
Insulation class : F  
Temperature rise : 80 K  
Locked rotor time : 28 s (hot)  
Service factor : 1.25  
Duty cycle : S1  
Ambient temperature : -20°C - +40°C  
Altitude : 1000  
Degree of Protection : IP55  
Approximate weight : 2029 lb  
Moment of inertia : 45.823 sq.ft.lb  
Noise level : 81 dB(A)

	D.E.	N.D.E.	Load	Power factor	Efficiency (%)
Bearings	6314 C3	6314 C3	100%	0.90	96.2
Regreasing interval	4000 h	4000 h	75%	0.88	96.2
Grease amount	27 g	27 g	50%	0.83	95.4

Notes:

Performed by

Checked



No.:

Date: 21-DEC-2012

### PERFORMANCE CURVES RELATED TO RATED OUTPUT

Three-phase induction motor - Squirrel cage rotor

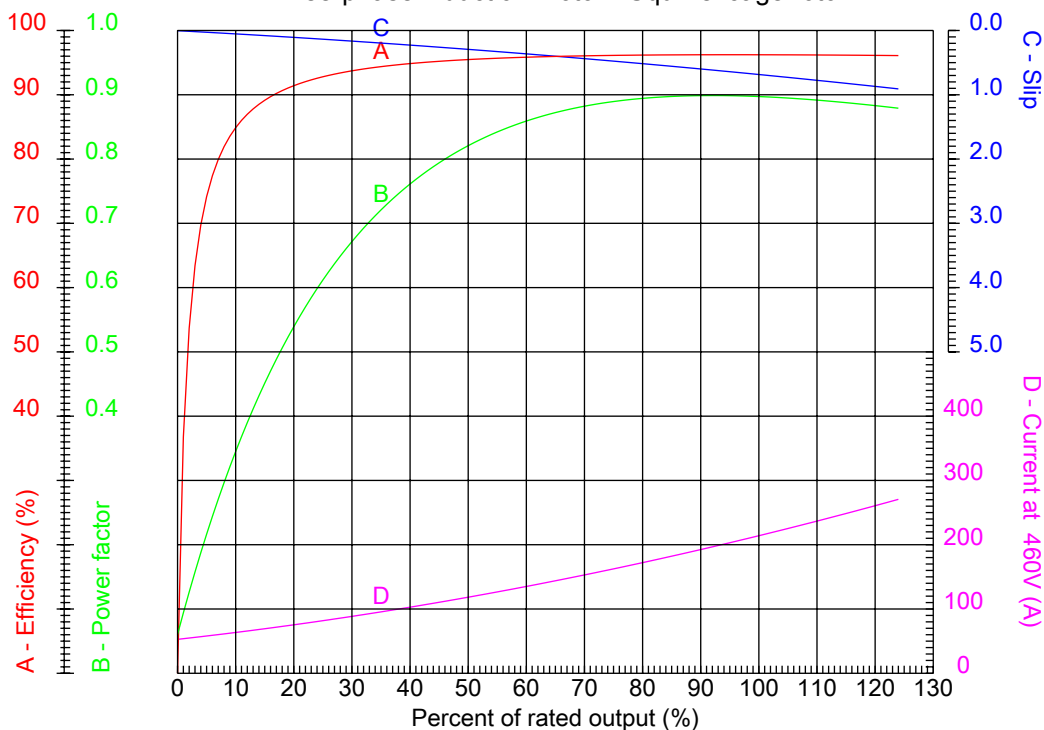

Customer :  
Product line : W22 Super Premium

Frame : 445/7TS	Locked rotor current (I <sub>l</sub> /I <sub>n</sub> ) : 7.3
Output : 200 HP	Duty cycle : S1
Frequency : 60 Hz	Service factor : 1.25
Full load speed : 3575	Design : A
Voltage : 460 V	Locked rotor torque : 240 %
Rated current : 217 A	Breakdown torque : 290 %
Insulation class : F	

Notes:

Performed by

Checked



No.:

Date: 21-DEC-2012

### CHARACTERISTIC CURVES RELATED TO SPEED Three-phase induction motor - Squirrel cage rotor

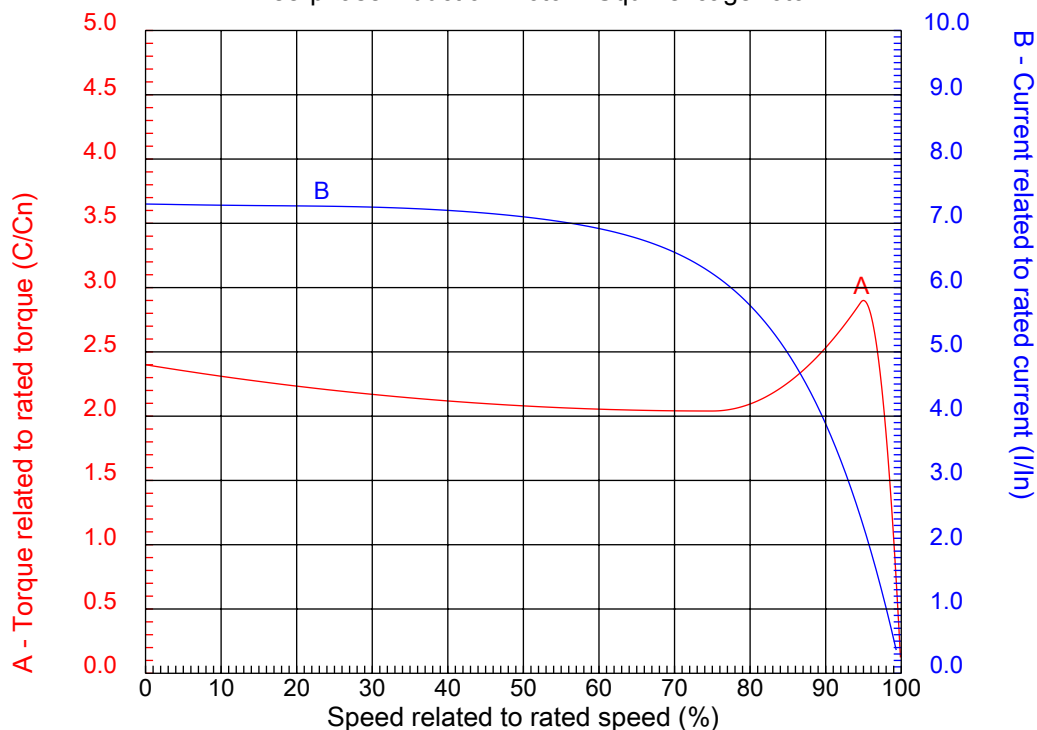

Customer :  
Product line : W22 Super Premium

Frame	: 445/7TS	Locked rotor current (I <sub>l</sub> /I <sub>n</sub> )	: 7.3
Output	: 200 HP	Duty cycle	: S1
Frequency	: 60 Hz	Service factor	: 1.25
Full load speed	: 3575	Design	: A
Voltage	: 460 V	Locked rotor torque	: 240 %
Rated current	: 217 A	Breakdown torque	: 290 %
Insulation class	: F		

Notes:

Performed by

Checked

1 2 3 4 5 6 7 8

A

B

C

D

E

F

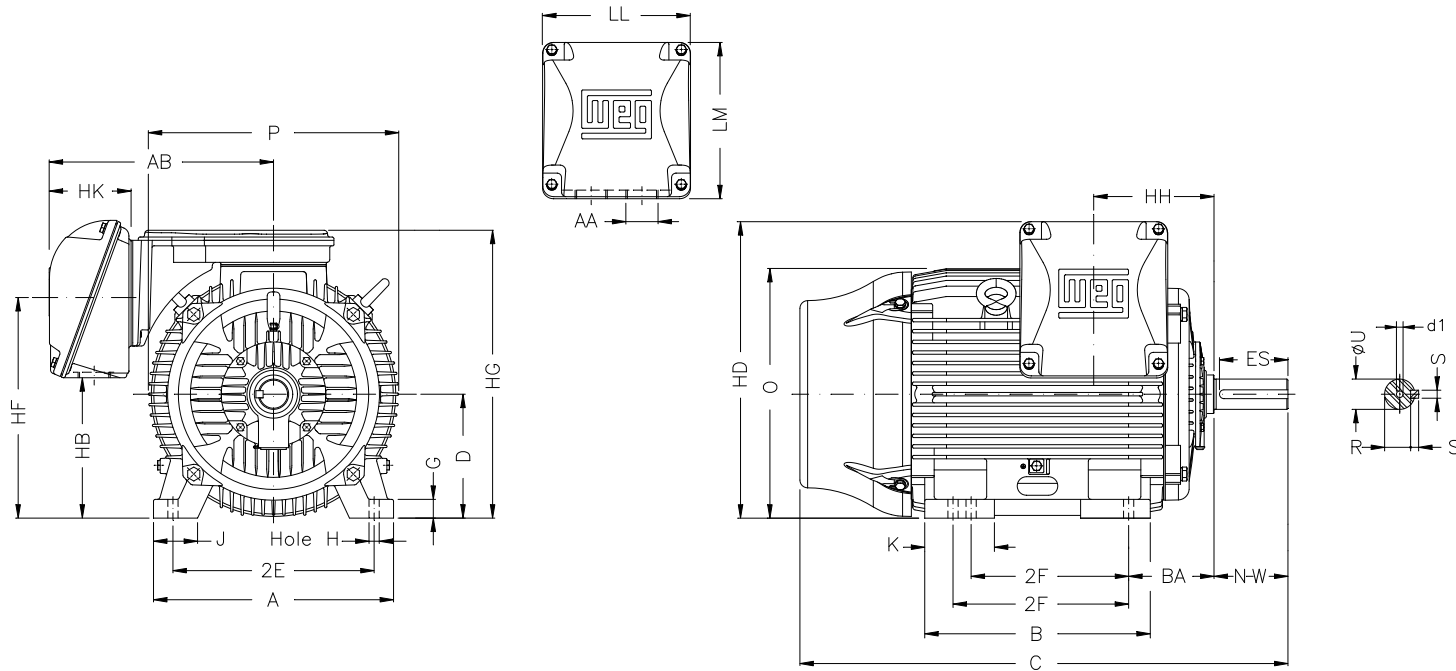

Notes:

Performed by:

Checked:

Customer:

W22 Super Premium

Three-phase induction motor  
Frame 445/7TS - IP55

21-DEC-2012



2E 18.000	J 3.937	A 21.929	P 23.583	AB 20.670
2F 16.500/20.000	K 5.866	B 23.897	BA 7.500	U 2.375
N-W 4.750	ES 3.000	S 0.625	R 2.021	depth 0.625
D 11.000	G 1.654	HB 12.598	O 22.795	T 7.378
HD 30.173	HF 20.724	HG 26.850	HH 11.803	HK 7.087
H 0.810	C 44.951	LL 14.921	LM 14.980	AA 2XNPT 3"
d1 DUNC 3/4"-10	d2 DUNC 3/4"-10	Flange FD-508	AJ 20.000	AK 18.000
BD 21.65	BF 0.828	BB 0.203		