

Open Hexagon Picnic Table

Item #ASM-OHT-02
by Polly Products



This Open Hexagon Picnic Table by Polly Products is designed with easy access seating so there is no need to step over a bench seat. This commercial quality outdoor hexagon table is built solid and designed with detailed Polly Planks to create a look that closely resembles wooden tables but without the added maintenance demands of wood. Made with 100% recycled plastic for a sustainable and eco-friendly product, this beautiful picnic table will last a lifetime!

- Maintenance free! No need to stain or paint
- Heavy duty and can be surface mounted with brackets
- Resists fading or peeling as the color is molded all the way through
- Weather resistant
- No need to stain or paint
- stainless steel fasteners are long-lasting and do not rust
- slatted design keeps rainwater from collecting on surfaces

See back of page for exact measurements and Available Color Options

www.pollyproducts.com



Polly Products
12 N. Charlotte St
Mulliken, MI 48861

1-877-609-2243

ASM-OHT-02

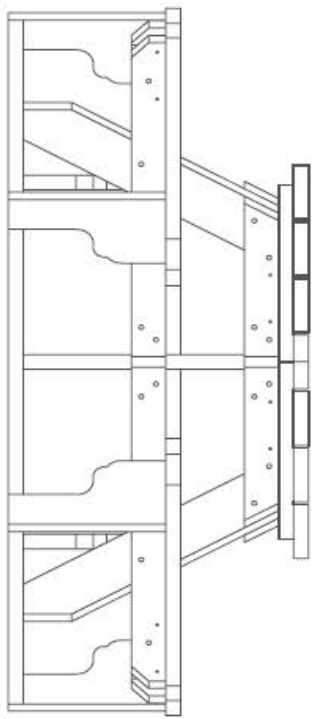
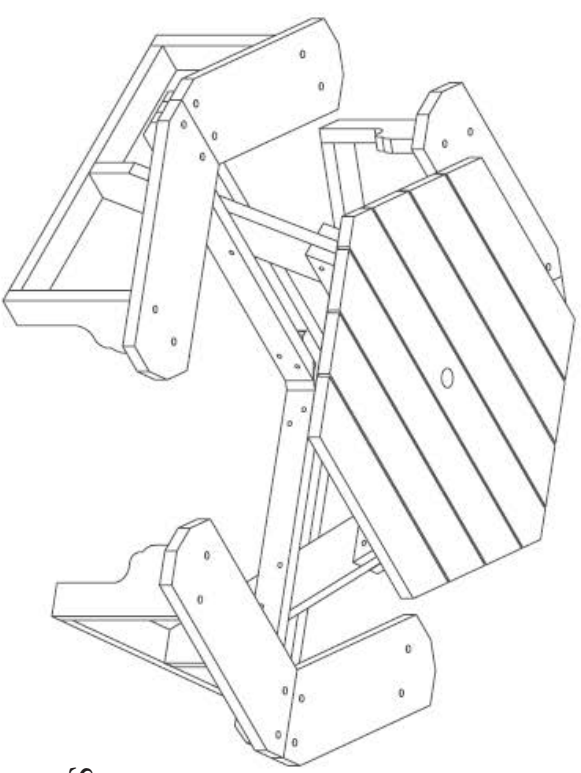
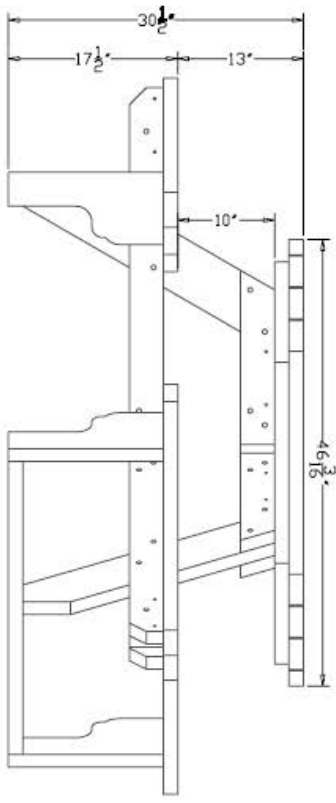
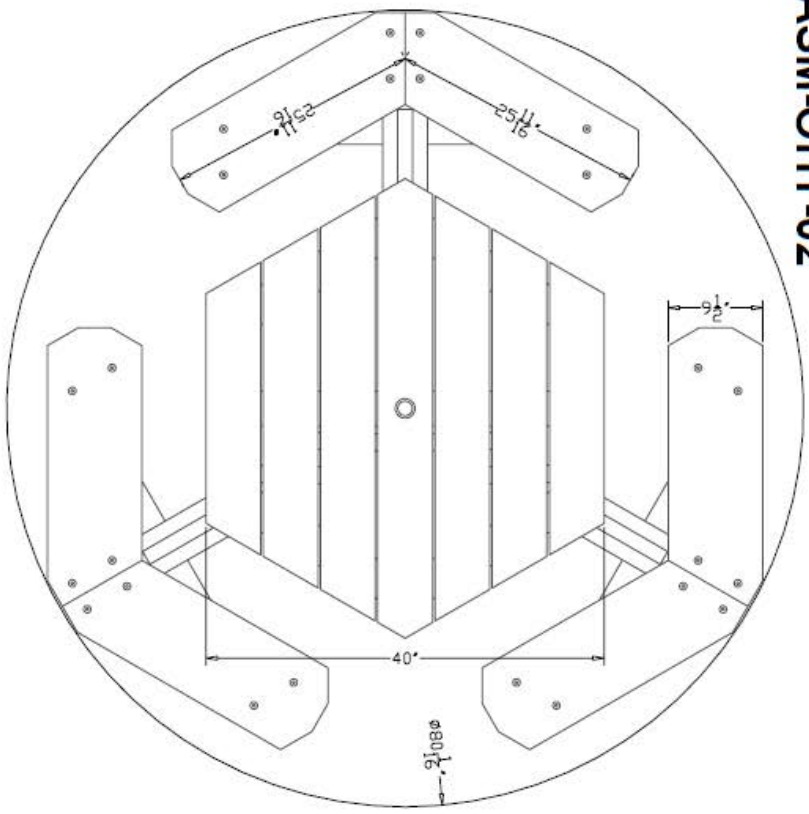

Frame Color Options

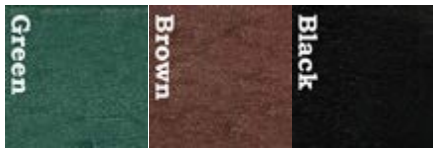

Seat/Table Color Options

