

UPLAY TODAY™

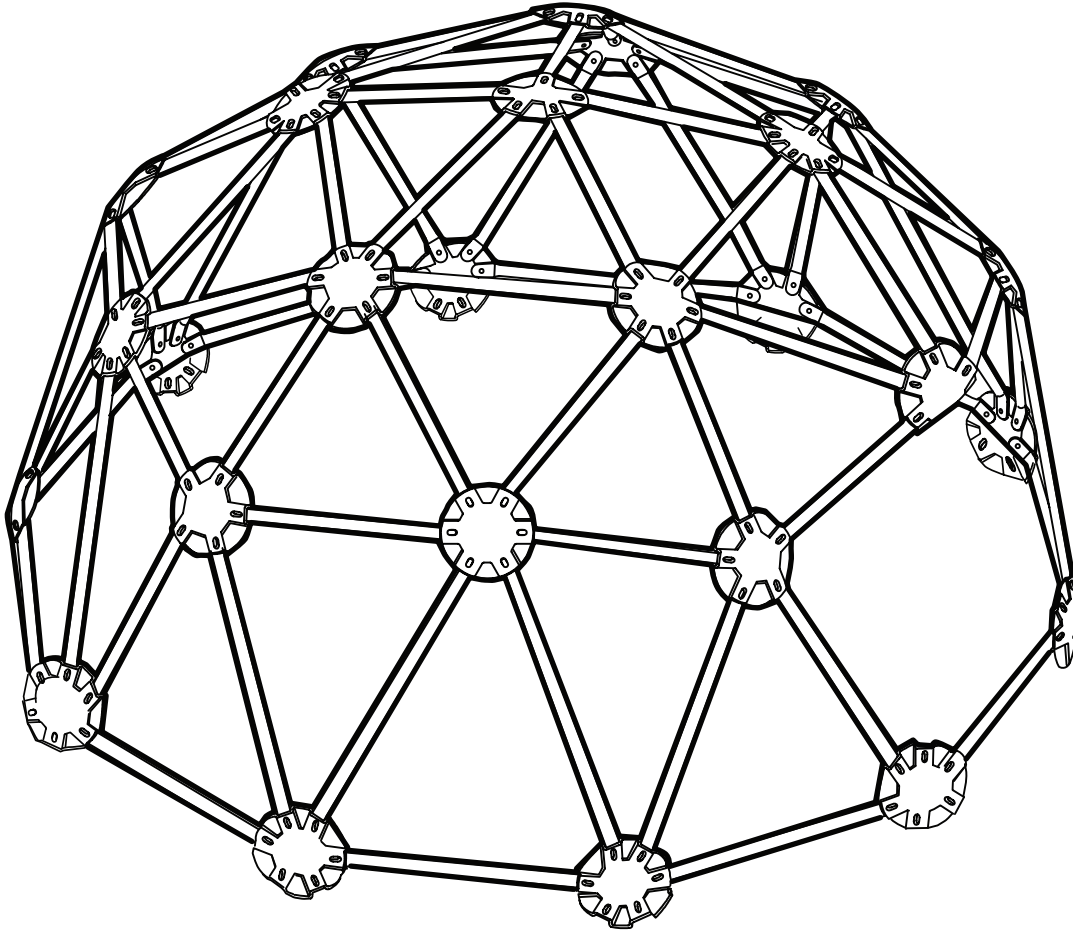

MODEL # PMOON

Geodome

ASSEMBLY INSTRUCTIONS

GROUND PLAN

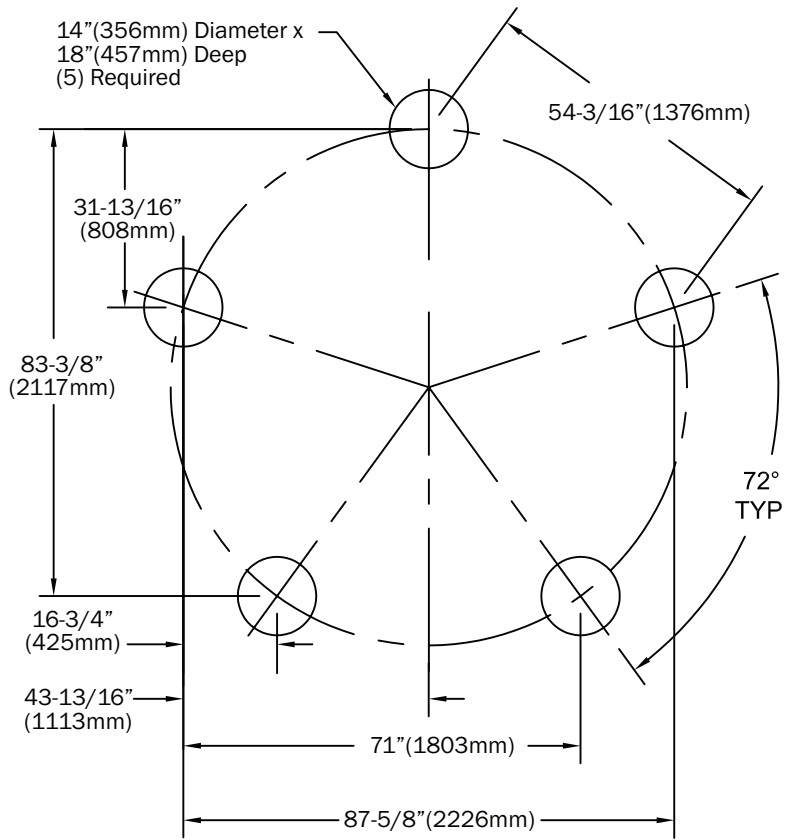

NOTE:

Hole depths indicated on all ground plans are measured from the finished surface. See *Footing Details*.

All Footer dimensions are based on level finished surface.

Concrete Required :

Approx. .3 Cubic Yards
(.23 Cubic Meters)

NOTE: Suggested

Min. concrete rating: 3000PSI

FOOTING DETAIL

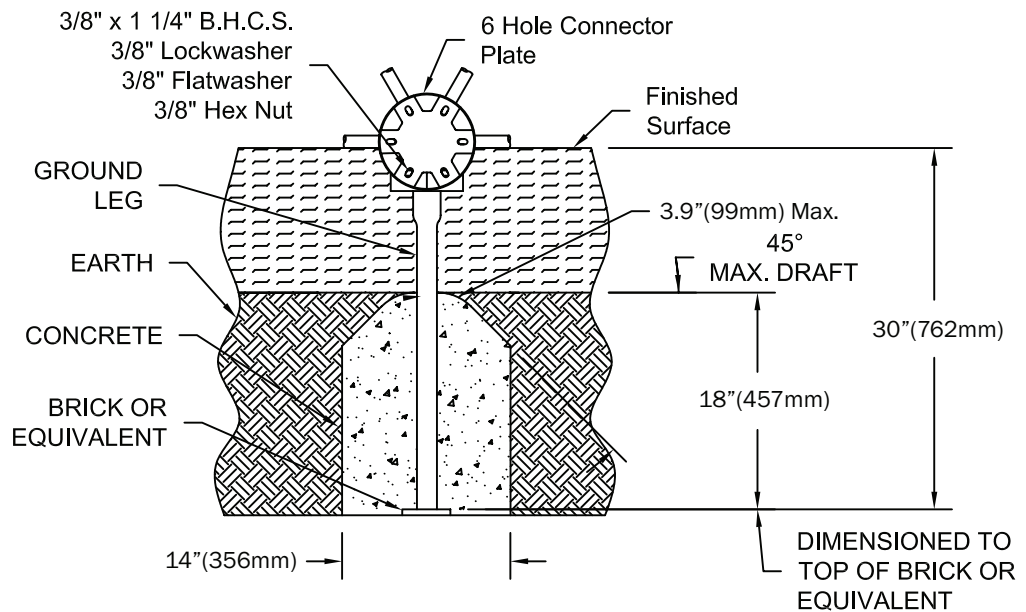

COMPONENTS

Parts List			
Letter	Description	Quantity	Part Number
A	Long Bar - 26" (660mm)	33	02-01-0015
B	Short Bar - 22-3/8" (568mm)	30	02-01-0016
C	Blue 5-Hole Connector Plate	6	02-01-0005
D	Yellow 6-Hole Connector Plate	10	02-01-0006
E	Red 6-Hole Connector Plate	9	02-01-0006
F	Yellow 4-Hole Connector Plate	1	02-01-0004
G	In-ground Footer	5	02-07-0086
	Hardware Complete	1	33-12-0000
H	3/8" x 3/4" Carriage Bolt	126	33-06-0059
I	3/8" Lock Nut	126	33-03-0001
J	3/8" x 1-1/4" B.H.C.S Bolt	10	33-05-0002
K	3/8" Flat Washer	20	33-02-0002
L	3/8" Lock Washer	10	33-02-0006
M	3/8" Hex Nut	10	33-01-0002

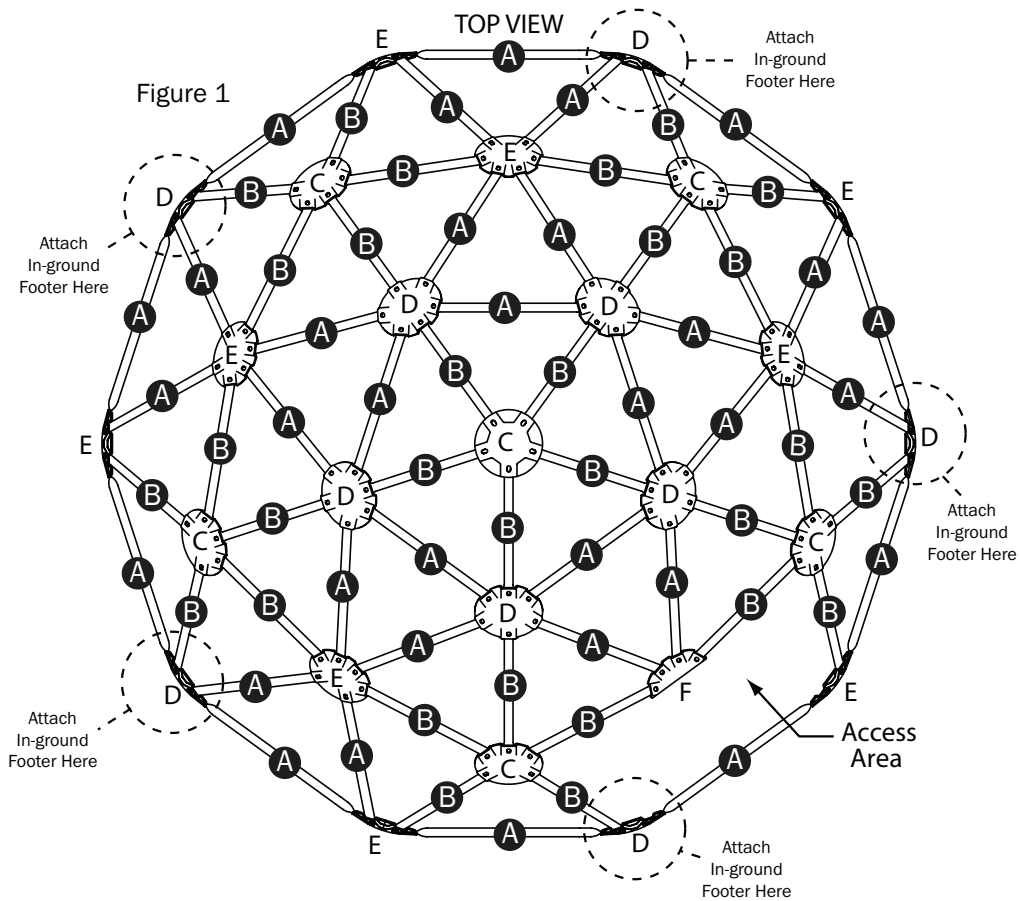

INSTRUCTIONS

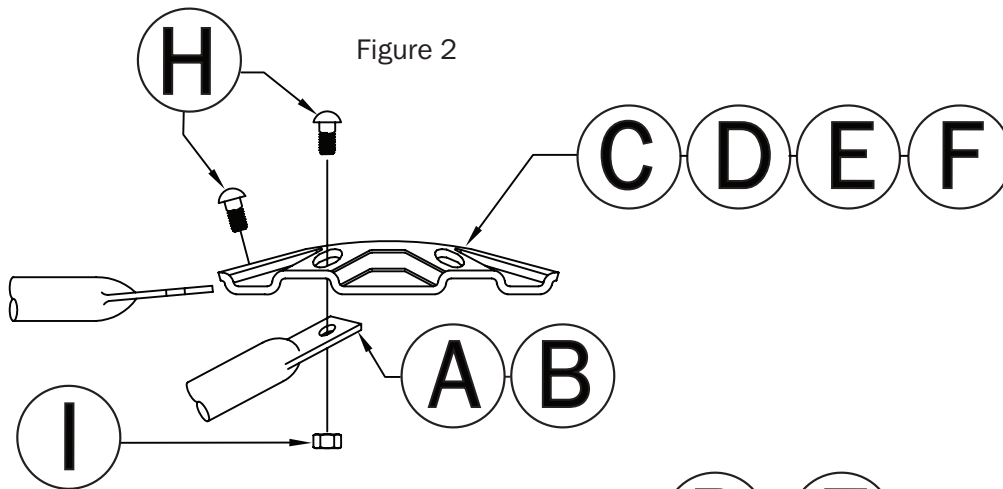

Figure 2

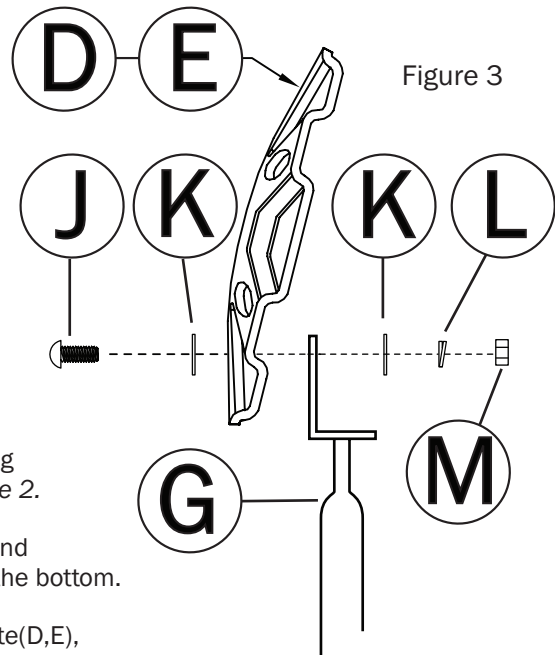

Figure 3

Read all assembly instructions thoroughly before starting assembly.

Assembly Instructions

1. Start at bottom of Geodome, working left to right, connect bottom Long Bars(A) using 6-hole Connecting Plates(D,E) and Carriage Bolts(H) and Self-locking Nuts(H). Finger tighten only. See Figure 2.

NOTE: It is important that the angle on the ends of the rung point outward from the center of the unit. See Figure 2.

2. Once bottom perimeter is assembled, bolt on (5) In-ground Footers(G) equally spaced around the circumference of the bottom.
3. Insert Hex Bolt(J) and Flat Washer(K) into Connector Plate(D,E), through In-ground Footer(G) and secure with 3/8" Flat Washer(K), 3/8" Lock Washer(L) and 3/8" Lock Nut (M). See Figure 3.
4. Repeat Step 3 for remaining (4) In-ground Footers(G).
5. Using the bottom section as a template, dig the five required holes 14"(356mm) diameter x 18"(457mm) deep. Place brick or equivalent in the bottom of the hole to provide a solid foundation for each In-ground Footer(G).
6. Place assembled section into holes, plumb level.
7. Continue assembling by working upward around the bottom of the Geodome. See Plan View.
8. When Geodome is completely assembled, tighten all bolts and torque to a maximum of 45 foot pounds with a torque wrench. Do not overtighten. Check for level.
9. Pour concrete to within 12"(305mm) of finished surface. See Footing Detail. Allow concrete 48 hours minimum to cure.

SPECIFICATIONS

SPECIFICATIONS

Bars: Shall be fabricated of 1-1/16”(27mm) O.D. galvanized pipe.

Connector Plate: Shall be fabricated of 11 gauge hot rolled steel, thermo-plastic coated after fabrication.

General: Size of Geodome shall be approximately 96” (2438mm) in diameter and 48”(1219mm) tall.

Hardware: All nuts, bolts, screws, inserts and lockwashers used in the assembly of all play equipment shall be stainless steel, yellow dichromate plated steel, blue-coat plated steel, mechanically galvanized or powder coated/yellow dichromate plated steel. All primary fasteners shall be 300 series stainless steel. Fasteners with yellow dichromate treatment have an electro deposited, 99.9% pure zinc substrate applied from a specially formulated solution sealed with a yellow dichromate top coat designed to work in conjunction with the zinc plating. Yellow dichromate has a 320% longer life to white corrosion and 275% longer to red corrosion than does hot-dip galvanizing.

Weight: 192lb./87.3 kg.

MAINTENANCE PROCEDURE:

Periodically check hardware for tightness and tighten as necessary. Always check all parts for breakage or wear, and immediately put equipment out of service until any faulty parts found are repaired or replaced. Also check all metal parts for rust, paint loss and touch-up paint as necessary with paint. Check welded areas and verify integrity. Check periodically resilient surfacing for appropriate depth and remove extraneous materials that could cause injury, infection or disease. Maintain detailed installation, inspection, maintenance and repair records for public-use playground equipment.